



CORNELL
UNIVERSITY
LIBRARY



GIFT OF

Mrs. Talitha Botsford

ARCH.

Cornell University Library
TA 405.M55.10

Mechanica of materials.



3 1924 015 346 798

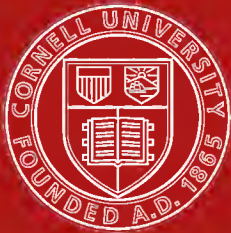

Cornell University
Library

The original of this book is in
the Cornell University Library.

There are no known copyright restrictions in
the United States on the use of the text.

<http://www.archive.org/details/cu31924015346798>

WORKS OF PROFESSOR MERRIMAN

PUBLISHED BY

JOHN WILEY & SONS

TREATISE ON HYDRAULICS. 8vo, 593 pages,	\$5.00
MECHANICS OF MATERIALS. 8vo, 518 pages,	\$5.00
PRECISE SURVEYING AND GEODESY. 8vo, 261 pages,	\$2.50
METHOD OF LEAST SQUARES. 8vo, 238 pages,	\$2.00
ELEMENTS OF SANITARY ENGINEERING. 8vo, 252 pages, <i>net</i> ,	\$2.00
ELEMENTS OF MECHANICS. 12mo, 172 pages, <i>net</i> ,	\$1.00
STRENGTH OF MATERIALS. 12mo, 156 pages, <i>net</i> ,	\$1.00

By Professors MERRIMAN and JACOBY

TEXT-BOOK ON ROOFS AND BRIDGES :

PART I. STRESSES. 8vo, 326 pages,	\$2.50
PART II. GRAPHIC STATICS. 8vo, 242 pages,	\$2.50
PART III. BRIDGE DESIGN. 8vo, 377 pages,	\$2.50
PART IV. HIGHER STRUCTURES. 8vo, 285 pages,	\$2.50

By Professors MERRIMAN and BROOKS

HANDBOOK FOR SURVEYORS. 12mo, 246 pages.	\$2.00
--	--------

Edited by Professors MERRIMAN and WOODWARD

SERIES OF MATHEMATICAL MONOGRAPHS.

Eleven Volumes, 8vo.

Each, \$1.00

MECHANICS
OF
MATERIALS

BY

MANSFIELD MERRIMAN

PROFESSOR OF CIVIL ENGINEERING IN LENIGN UNIVERSITY

TENTH EDITION, REWRITTEN AND ENLARGED

TOTAL ISSUE, TWENTY-THREE THOUSAND

NEW YORK

JOHN WILEY & SONS

LONDON: CHAPMAN & HALL, LIMITED

1907

ET

COPYRIGHT, 1885, 1890, 1895, 1905

BY

MANSFIELD MERRIMAN

First Edition, June, 1885

Second Edition, revised and enlarged, April, 1890

Third Edition, February, 1891

Fourth Edition, June, 1892; reprinted, 1893

Fifth Edition, February, 1894; reprinted, 1895

Sixth Edition, enlarged, September, 1895; reprinted, 1896

Seventh Edition, July, 1897

Eighth Edition, February, 1899

Ninth Edition, June, 1900; reprinted, 1901, 1902, 1903 (twice), 1904, 1905

Tenth Edition, rewritten and enlarged, September, 1905

Reprinted, 1906, 1907

ALL RIGHTS RESERVED

99519B
50A
G

ROBERT DRUMMOND, PRINTER, NEW YORK

PREFACE

SINCE 1885, when the first edition of this work was published, many advances have been made in the subject of Mechanics of Materials. Some of these have been noted in the additions to subsequent editions, but to record and correlate them properly it has now become necessary to rewrite and reset the book. In doing so the author has endeavored to keep the facts of experiment and practice constantly in view, for the theory of the subject is merely the formal expression and generalization of observed phenomena. The subject, indeed, no longer consists of a series of academic exercises in algebra and rational mechanics, but it is indispensably necessary that the phenomena of stress should be clearly understood by the student. While laboratory work is a valuable aid to this end, it is important, in the opinion of the author, that no recitation or lecture should be held without having test specimens at hand with which to illustrate the physical phenomena.

The same general plan of treatment has been followed as before, but the subdivisions are somewhat different, and the fifteen chapters of the last edition have been increased to nineteen. The statement of average values of the principal materials of engineering has proved so advantageous to students that it is here also followed. Numerous numerical examples are given in the text to exemplify the formulas and methods, these generally relating to cases that arise in practice. To encourage students to think for themselves, one or more problems are given at the end of each article; for the experience of the author has indicated that the solution of many numerical exercises is required in order that students may become well grounded in theory.

Most of the topics of the last edition have been treated in a fuller manner than before. The subjects of impact on bars and beams, resilience and work, and apparent and true stresses

have been much changed with the intention of rendering the presentation more clear and accurate. Among many new topics introduced are those of economic sections for beams, moving loads on beams, constrained beams with supports on different levels, the torsion of rectangular bars, compound columns and beams, reinforced-concrete beams, plates under concentrated loads, internal friction, rules for testing materials, and elastic-electric analogies. A few changes in algebraic notation have been made in order that similar quantities may always be designated by letters of the same type; Greek letters are used only for angles and abstract numbers.

Compared with the ninth edition, the number of articles has been increased from 151 to 188, the number of tables from 8 to 20, the number of cuts from 85 to 250, and the number of problems from 222 to 305. Although the length of each page has been increased eight percent and smaller type has been used for formulas and problems, the number of pages has been increased from 378 to 518. While the main purpose in rewriting and enlarging the book has been to keep it abreast with modern progress, the attempt has also been made to present the subject more clearly and logically than before, in order both to advance the interests of sound engineering education and to promote sound engineering practice.

NOTE

This impression differs from the preceding one mainly in the discussion of reinforced concrete beams and of circular plates, Arts. 114, 115, 116, 160 having been rewritten. Minor changes have been made in other articles and all known typographic errors have been removed.

MANSFIELD MERRIMAN.

LEHIGH UNIVERSITY, SOUTH BETHLEHEM, PA.,
December, 1906.

CONTENTS

CHAPTER I

ELASTIC AND ULTIMATE STRENGTH

	PAGE
ART. 1. SIMPLE AXIAL STRESSES	1
2. THE ELASTIC LIMIT.	4
3. ULTIMATE STRENGTH	6
4. TENSION	9
5. COMPRESSION	11
6. SHEAR	14
7. WORKING UNIT-STRESSES	16
8. COMPUTATIONS AND EQUATIONS	19

CHAPTER II

ELASTIC AND ULTIMATE DEFORMATION

ART. 9. MODULUS OF ELASTICITY	23
10. ELASTIC CHANGE OF LENGTH	25
11. ELASTIC LIMIT AND YIELD POINT	27
12. ULTIMATE DEFORMATIONS	30
13. CHANGES IN SECTION AND VOLUME	32
14. WORK IN PRODUCING DEFORMATION	35
15. SHEARING MODULUS OF ELASTICITY	37
16. HISTORICAL NOTES	39

CHAPTER III

MATERIALS OF ENGINEERING

ART. 17. AVERAGE WEIGHTS	42
18. PLASTICITY AND BRITTLINESS	43
19. TIMBER	46
20. BRICK	48
21. STONE	50
22. MORTAR AND CONCRETE	52
23. CAST IRON	55
24. WROUGHT IRON	57
25. STEEL	60
26. OTHER MATERIALS	66

CHAPTER IV

CASES OF SIMPLE STRESS

	PAGE
ART. 27. STRESS UNDER OWN WEIGHT	69
28. BAR OF UNIFORM STRENGTH	71
29. ECCENTRIC LOADS	72
30. WATER AND STEAM PIPES	75
31. THIN CYLINDERS AND SPHERES	77
32. SHRINKAGE OF HOOPS	79
33. INVESTIGATION OF RIVETED JOINTS	80
34. DESIGN OF RIVETED JOINTS	83

CHAPTER V

GENERAL THEORY OF BEAMS

ART. 35. DEFINITIONS	87
36. REACTIONS OF SUPPORTS	88
37. THE VERTICAL SHEAR	90
38. THE BENDING MOMENT	93
39. INTERNAL STRESSES AND EXTERNAL FORCES	96
40. NEUTRAL SURFACE AND AXIS	98
41. SHEAR AND FLEXURE FORMULAS	101
42. CENTER OF GRAVITY	103
43. MOMENTS OF INERTIA	105
44. ROLLED BEAMS AND SHAPES	108
45. ELASTIC DEFLECTIONS	112

CHAPTER VI

SIMPLE AND CANTILEVER BEAMS

ART. 46. SHEAR AND MOMENT DIAGRAMS	116
47. MAXIMUM SHEARS AND MOMENTS	119
48. INVESTIGATION OF BEAMS	121
49. SAFE LOADS FOR BEAMS	124
50. DESIGNING OF BEAMS	125
51. ECONOMIC SECTIONS	127
52. RUPTURE OF BEAMS	130
53. MOVING LOADS	132
54. DEFLECTION OF CANTILEVER BEAMS	135
55. DEFLECTION OF SIMPLE BEAMS	138
56. COMPARATIVE STRENGTH AND STIFFNESS	141
57. CANTILEVER BEAMS OF UNIFORM STRENGTH	143
58. SIMPLE BEAMS OF UNIFORM STRENGTH	146

CHAPTER VII

OVERHANGING AND FIXED BEAMS

	PAGE
ART. 59. BEAM OVERHANGING ONE SUPPORT	149
60. BEAM FIXED AT ONE END	152
61. BEAM OVERHANGING BOTH SUPPORTS	154
62. BEAM FIXED AT BOTH ENDS	156
63. COMPARISON OF BEAMS	158
64. SUPPORTS ON DIFFERENT LEVELS	159
65. CANTILEVER WITH CONSTRAINT	163
66. SPECIAL DISCUSSIONS	164

CHAPTER VIII

CONTINUOUS BEAMS

ART. 67. GENERAL PRINCIPLES	168
68. METHOD OF DISCUSSION	171
69. THEOREM OF THREE MOMENTS	173
70. EQUAL SPANS WITH UNIFORM LOAD	175
71. UNEQUAL SPANS AND LOADS	177
72. SPANS WITH FIXED ENDS	179
73. CONCENTRATED LOADS	180
74. SUPPORTS ON DIFFERENT LEVELS	182
75. THE THEORY OF FLEXURE	184

CHAPTER IX

COLUMNS OR STRUTS

ART. 76. CROSS-SECTIONS OF COLUMNS	188
77. DEFINITIONS AND PRINCIPLES	190
78. EULER'S FORMULA FOR LONG COLUMNS	192
79. EXPERIMENTS ON COLUMNS	196
80. RANKINE'S FORMULA	200
81. INVESTIGATION OF COLUMNS	203
82. SAFE LOADS FOR COLUMNS	205
83. DESIGNING OF COLUMNS	206
84. THE STRAIGHT-LINE FORMULA	208
85. OTHER COLUMN FORMULAS	211
86. ECCENTRIC LOADS ON PRISMS	214
87. ECCENTRIC LOADS ON COLUMNS	217
88. ON THE THEORY OF COLUMNS	220

CHAPTER X

TORSION OF SHAFTS

	PAGE
ART. 89. PHENOMENA OF TORSION	225
90. THE TORSION FORMULA	227
91. SHAFTS FOR TRANSMITTING POWER	250
92. SOLID AND HOLLOW SHAFTS	231
93. TWIST OF SHAFTS	233
94. RUPTURE OF SHAFTS	235
95. STRENGTH AND STIFFNESS	237
96. SHAFT COUPLINGS	239
97. A SHAFT WITH CRANK	240
98. A TRIPLE-CRANK SHAFT	242
99. NON-CIRCULAR SECTIONS	245

CHAPTER XI

APPARENT COMBINED STRESSES

ART. 100. STRESSES DUE TO TEMPERATURE	251
101. BEAMS UNDER AXIAL FORCES	253
102. FLEXURE AND COMPRESSION	255
103. FLEXURE AND TENSION	259
104. ECCENTRIC AXIAL FORCES ON BEAMS	261
105. SHEAR AND AXIAL STRESS	263
106. FLEXURE AND TORSION	266
107. COMPRESSION AND TORSION	268
108. HORIZONTAL SHEAR IN BEAMS	269
109. LINES OF STRESS IN BEAMS	272

CHAPTER XII

COMPOUND COLUMNS AND BEAMS

ART. 110. BARS OF DIFFERENT MATERIALS	276
111. COMPOUND COLUMNS	279
112. FLITCHED BEAMS	282
113. REINFORCED CONCRETE BEAMS	285
114. THEORY OF REINFORCED CONCRETE BEAMS	289
115. INVESTIGATION OF REINFORCED CONCRETE BEAMS	292
116. DESIGN OF REINFORCED CONCRETE BEAMS	295
117. PLATE GIRDERS	298
118. DEFLECTION OF COMPOUND BEAMS	300

CHAPTER XIII

RESILIENCE AND WORK

	PAGE
ART. 119. EXTERNAL WORK AND INTERNAL ENERGY	303
120. RESILIENCE OF BARS	306
121. RESILIENCE OF BEAMS	308
122. RESILIENCE IN SHEAR AND TORSION	310
123. DEFLECTION UNDER ONE LOAD	312
124. DEFLECTION AT ANY POINT	314
125. DEFLECTION DUE TO SHEAR	316
126. PRINCIPLE OF LEAST WORK	320

CHAPTER XIV

IMPACT AND FATIGUE

ART. 127. SUDDEN LOADS AND STRESSES	324
128. AXIAL IMPACT ON BARS	327
129. TRANSVERSE IMPACT ON BEAMS	329
130. INERTIA IN AXIAL IMPACT	331
131. INERTIA IN TRANSVERSE IMPACT	334
132. VIBRATIONS AFTER IMPACT	338
133. EXPERIMENTS ON ELASTIC IMPACT	341
134. PRESSURE DURING IMPACT	344
135. IMPACT CAUSING RUPTURE	346
136. STRESSES DUE TO LIVE LOADS	349
137. THE FATIGUE OF MATERIALS	352
138. STRENGTH UNDER FATIGUE	355

CHAPTER XV

TRUE INTERNAL STRESSES

ART. 139. PRINCIPLES AND LAWS	359
140. SHEAR DUE TO NORMAL STRESS	362
141. COMBINED SHEAR AND AXIAL STRESS	365
142. TRUE STRESSES FOR BEAMS	367
143. NORMAL STRESSES DUE TO SHEAR	369
144. TRUE STRESSES IN SHAFTS	371
145. PURE INTERNAL STRESS	373
146. INTERNAL FRICTION	375
147. THEORY OF INTERNAL FRICTION	378

CONTENTS

CHAPTER XVI

GUNS AND THICK CYLINDERS

	PAGE
ART. 148. PRINCIPLES AND METHODS	383
149. LAMÉ'S FORMULAS	385
150. SOLID GUNS AND THICK PIPES	388
151. A COMPOUND CYLINDER	390
152. CLAVARINO'S FORMULAS	392
153. BIRNIE'S FORMULAS	394
154. HOOP SHRINKAGE	396
155. DESIGN OF HOOPED GUNS	399

CHAPTER XVII

ROLLERS, PLATES, SPHERES

ART. 156. CYLINDRICAL ROLLERS	403
157. SPHERICAL ROLLERS	406
158. CONTACT OF CONCENTRATED LOADS	407
159. CIRCULAR PLATES WITH UNIFORM LOAD	409
160. CIRCULAR PLATES WITH CONCENTRATED LOAD	411
161. ELLIPTICAL PLATES	414
162. RECTANGULAR PLATES	415
163. HOLLOW SPHERES	417

CHAPTER XVIII

MISCELLANEOUS DISCUSSIONS

ART. 164. CENTRIFUGAL TENSION	421
165. CENTRIFUGAL FLEXURE	425
166. UNSYMMETRIC LOADS ON BEAMS	427
167. EULER'S MODIFIED FORMULA	431
168. TESTING MACHINES	433
169. TESTS OF MATERIALS	436
170. RULES FOR TESTING	442
171. SPECIFICATIONS FOR STRUCTURAL STEEL	444

CHAPTER XIX

MATHEMATICAL THEORY OF ELASTICITY

ART. 172. INTRODUCTION	448
173. ELASTIC CHANGES IN VOLUME	449
174. NORMAL AND TANGENTIAL STRESSES	452
175. RESULTANT STRESSES	454
176. THE ELLIPSOID OF STRESS	456
177. THE THREE PRINCIPAL STRESSES	457

	PAGE
178. MAXIMUM SHEARING STRESSES	459
179. DISCUSSION OF A CRANK PIN	461
180. THE ELLIPSE OF STRESS	463
181. SHEARING MODULUS OF ELASTICITY	465
182. THE VOLUMETRIC MODULUS	467
183. STORED INTERNAL ENERGY	469

APPENDIX

ART. 184. VELOCITY OF STRESS	472
185. ELASTIC-ELECTRIC ANALOGIES	474
186. MISCELLANEOUS PROBLEMS	475
187. ANSWERS TO PROBLEMS	477
188. EXPLANATION OF TABLES	478

TABLES

TABLE 1. AVERAGE WEIGHT AND EXPANSIBILITY	480
2. AVERAGE ELASTIC PROPERTIES	480
3. AVERAGE TENSILE AND COMPRESSIVE STRENGTH	481
4. AVERAGE SHEARING AND FLEXURAL STRENGTH	481
5. WORKING UNIT-STRESSES FOR BUILDINGS	482
6. STEEL I-BEAM SECTIONS	483
7. STEEL BULB-BEAM SECTIONS	484
8. STEEL T SECTIONS	484
9. STEEL CHANNEL SECTIONS	485
10. STEEL ANGLE SECTIONS	489
11. STEEL Z SECTIONS	487
12. COMPARISON OF BEAMS	487
13. GERMAN I BEAMS	488
14. WEIGHT OF WROUGHT-IRON BARS	489
15. SQUARES OF NUMBERS	490
16. AREAS OF CIRCLES	492
17. TRIGONOMETRIC FUNCTIONS	494
18. LOGARITHMS OF TRIGONOMETRIC FUNCTIONS	495
19. LOGARITHMS OF NUMBERS	496
20. CONSTANTS AND THEIR LOGARITHMS	498

INDEX	499
-----------------	-----

MECHANICS OF MATERIALS

CHAPTER I

ELASTIC AND ULTIMATE STRENGTH

ARTICLE 1. SIMPLE AXIAL STRESSES

Mechanics of Materials is the science that treats of the effects of forces in causing changes in the size and shape of bodies. Such forces are generally applied to bodies slowly, and the changes in size and shape occur while the forces are increasing up to their final values. A 'Stress' is an internal force that resists the change in shape or size, and when the applied forces have reached their final values the internal stresses hold them in equilibrium. The simplest case is that of a rope, at each end of which a man pulls with a force, say 25 pounds, then in every section of the rope there exists a stress of 25 pounds. Stresses are measured in the same unit as that used for the applied forces, and generally in pounds or kilograms.

A 'Bar' is a prismatic body having the same size throughout its length. If a plane is passed normal to the bar, its intersection with the prism is called the 'cross-section' or the 'section' of the bar, and the area of this cross-section is called the 'section area.' In any section imagined to be cut out, there exists a stress equal to the longitudinal force acting on the end of the bar. A 'Unit-Stress' is the stress on a unit of the section area, and this is usually expressed in pounds per square inch or in kilograms per square centimeter. For example, let a bar, 3 inches wide and $1\frac{1}{2}$ inches thick, be subjected to a pull of 14 400 pounds; the resisting stress is 14 400 pounds, and the unit-stress is 14 400 pounds divided by $4\frac{1}{2}$ square inches, or 3 200 pounds per square inch.

When external forces act upon the ends of a bar in a direction away from its ends they are called 'Tensile Forces'; when they act towards the ends, they are called 'Compressive Forces.' A pull is a tensile force and a push is a compressive force, and these two cases are frequently called 'Tension' and 'Compression'. The resisting stresses receive similar designations; a tensile stress is that which resists tensile forces; a compressive stress is that which resists compressive forces.

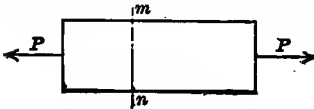

Fig. 1a

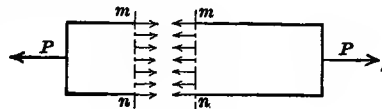

Fig. 1b

The case of tension is shown in Fig. 1a, where two tensile forces, each equal to P , act upon the ends of a bar having the section area a . Let mn be any imaginary plane normal to the bar, and let the two parts of the bar be imagined to be separated as in Fig. 1b. Then the equilibrium of each part will be maintained if tensile forces equivalent to the resisting stresses are applied as shown. These resisting stresses act normally to the section area a , and they are in each case opposite in direction to the force P . Each part of the bar is held in equilibrium by the applied force P and the resisting tensile stress; accordingly the resisting tensile stress must equal the tensile force P .

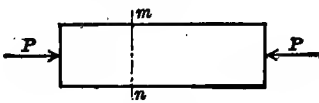

Fig. 1c

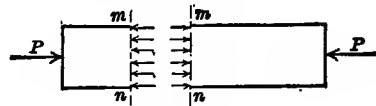

Fig. 1d

The case of compression is shown in Fig. 1c, where the forces P act toward the ends of the bar. For any imaginary plane mn , the bar may be regarded as separated into two bars as in Fig. 1d, each of which is held in equilibrium by compressive stresses acting normally to the section area and in directions opposite to P . The total resisting compressive stress must be equal to P in order that equilibrium may prevail.

Let S be the unit-stress of tension or compression, as the case may be, which acts in any normal section of a bar having the area a . The total stress on the section is then Sa , and this is uniformly distributed over the area a when the force P acts along the axis of the bar; then,

$$Sa = P \qquad S = P/a \qquad a = P/S \qquad (1)$$

from which one of the quantities may be computed when the other is given. For example, let it be required to find what the section area of a stick of timber should be when it is subject to a pull of 16 500 pounds, it being required that the tensile unit-stress shall be 900 pounds per square inch; here $a = 16\,500/900 = 18.3$ square inches.

The terms 'Axial Forces' and 'Axial Stresses' are used to include both tension and compression acting upon a bar, it being understood that the resultant of the applied forces acts along the axis of the bar. The axial force P is often called a 'Load'. It is always understood, unless otherwise stated, that the stresses due to an axial load are uniformly distributed over the section area, and this is called the case of 'Simple Axial Stress', it being one of the most common cases in engineering. Cases where the stress is not uniformly distributed over the section area occur when the resultant of the applied forces does not act along the axis of the bar, and also in beams and long columns.

The first effect of an axial load is to change the length of the bar upon which it acts. This 'Deformation' continues until the resisting stresses have attained such magnitudes that they equilibrate the applied forces. The deformation of a bar which occurs in tension is called 'Elongation', and that which occurs in compression is called 'Shortening'. As the applied forces increase, the resisting stresses also increase, until finally the resistance is unable to balance the force, the deformation rapidly increases, and the bar breaks or ruptures. The above equations apply also to the case of rupture. For example, it is known that a cast-iron bar will rupture under tension when the unit-stress S becomes about 20 000 pounds per square inch; if the bar is $1\frac{1}{2} \times 1\frac{1}{4}$ inches in cross-section, its section area is $1\frac{7}{8}$ square

inches, and the tensile force required to cause rupture is $P = 1\frac{7}{8} \times 20\ 000 = 37\ 500$ pounds.

Problem 1a. If a cast-iron bar, $1\frac{1}{2} \times 2$ inches in section, breaks under a tensile load of 60 000 pounds, what load will break a cast-iron rod of $2\frac{1}{4}$ inches diameter?

Prob. 1b. A cast-iron bar which is to be subjected to a tension of 34 000 pounds is to be designed so that the unit-stress shall be 2 500 pounds per square inch. If the bar is round what should be its diameter?

ART. 2. THE ELASTIC LIMIT

When a bar is subjected to a gradually increasing tension, the bar elongates, and up to a certain limit it is found that the elongation is proportional to the load. Thus, when a bar of wrought iron one square inch in section area and 100 inches long is subjected to a load of 5 000 pounds, it is found to elongate closely 0.02 inches; when 10 000 pounds is applied, the total elongation is 0.04 inches; when 15 000 pounds is applied, the elongation is 0.06 inches; when 20 000 pounds is applied, the elongation is 0.08 inches; when 25 000 pounds is applied, the elongation is 0.10 inches. Thus far, each addition of 5 000 pounds has produced an additional elongation of 0.02 inches. But when the next 5 000 pounds is added, making a total load of 30 000 pounds, it is found that the total elongation is about half an inch, and hence the elongations are increasing in a faster ratio than the applied loads and the resisting stresses.

The 'Elastic Limit' is defined to be that unit-stress at which the deformation begins to increase in a faster ratio than the applied loads. In the above example this limit is about 25 000 pounds per square inch, and this is the average value of the elastic limit for wrought iron. The term 'Elastic Strength' is perhaps a better term than elastic limit, but the latter is in general use.

When the unit-stress in a bar is not greater than the elastic limit, the bar returns, on the removal of the load, to its original length. Thus, the above wrought-iron bar was 100.10 inches long under the load of 25 000 pounds, and on the removal of that load

it returns to its original length of 100.00 inches. When the unit-stress is greater than the elastic limit, the bar does not fully return to its original length, but there remains a so-called 'Permanent Set'. For instance let the length of the above bar under a stress of 34 000 pounds be 102 inches, and on the removal of the tension let its length be $101\frac{7}{8}$ inches; then the permanent set of the bar is $1\frac{7}{8}$ inches.

In all cases of simple axial tension the resisting stress is equal to the load, and the stresses hence increase proportionately to the loads. When the elastic limit is not exceeded, the elongations are found to be proportional to the loads, but when this limit is exceeded they increase faster than the loads, and a permanent set remains. Therefore the elastic properties of a bar are injured when it is stressed beyond the elastic limit. Accordingly it is a fundamental rule in designing engineering constructions that the unit-stresses should not exceed the elastic limit of the material.

The above facts regarding the behavior of materials in tension have been ascertained by many tests of bars and are to be regarded as fundamental laws; all experience and all experiments have verified these laws as being approximately true for the common materials used in engineering. By such tests also it has been shown that such laws apply to compression as well as to tension. The following are approximate average values of the elastic limits in tension for five materials extensively used in engineering construction:

Material	Elastic Limit
Timber	3 000 pounds per square inch
Cast Iron	6 000 pounds per square inch
Wrought Iron	25 000 pounds per square inch
Structural Steel	35 000 pounds per square inch
Strong Steel	50 000 pounds per square inch

These values should be carefully memorized by the student, and be used in the solution of the problems in the following pages. Table 2, at the end of this volume, gives these constants in the metric system of measures.

The above average values are subject to considerable varia-

tion for different qualities of the same material; for example, some grades of structural steel may have an elastic limit ten percent lower than 35 000 pounds per square inch, while others may run ten percent higher. In testing a number of bars of the same kind, indeed, it is not uncommon to find a variation of five or ten percent in the different results.

The elastic limit in compression is the same as that in tension for all the above materials except cast iron, which has about three times the value above given. Brittle materials, like brick, stone, and cast iron, usually have higher elastic limits in compression than in tension, but it will be seen later that the elastic limits for such materials are poorly defined, that is it is difficult to determine them with exactness.

By the help of the above experimental values and the principles of Art. 1, many simple problems in investigation and design may be solved. For example, let it be required to find the size of a square stick of timber to carry a compressive load of 64 000 pounds, so that the unit-stress may be one-third of the elastic limit; here the elastic limit is 3 000 pounds per square inch, and the section area required is $64\,000/1\,000$, or 64 square inches, so that a stick 8×8 inches in size is needed.

Prob. 2a. Find the diameter of a round rod of wrought iron, which is to be under a tension of 84 000 pounds, so that the unit-stress may be one-third of the elastic limit.

Prob. 2b. A stick of timber 3 inches thick is under a tension of 12 000 pounds. Compute its width, so that the unit-stress may be 40 percent of the elastic limit.

ART. 3. ULTIMATE STRENGTH

When the section area of a bar is under an axial unit-stress exceeding the elastic limit of its material, the bar is usually in an unsafe condition. As the external forces increase, the deformation increases in a more rapid ratio, until finally the rupture of the bar occurs. The term 'ultimate strength' is used to designate the highest unit-stress that the bar can sustain, this occurring at or just before rupture.

The ultimate strengths of materials are usually from two to four times their elastic limits, and for some materials they are much higher in compression than in tension. Thus, the ultimate tensile strength of cast iron is about 20 000 pounds per square inch, while its ultimate compressive strength is about 90 000 pounds per square inch.

Average values of the ultimate strengths of materials are given in the following articles, but these are subject to much variation for different qualities of materials. Thus, inferior grades of cast iron may have a tensile strength as low as 15 000 pounds per square inch, while the best grades are often higher than 30 000 pounds per square inch. In general a variation of ten percent from these average values is to be regarded as liable to occur.

The 'Factor of Safety' of a bar under stress is the number which results by dividing the ultimate strength of the material by the actual unit-stress on the section area. For example, let a stick of timber, 6×6 inches in section area, be under a tension of 32 400 pounds. The actual unit-stress is then $32\,400/36 = 900$ pounds per square inch. Since the average tensile strength of timber is about 10 000 pounds per square inch, the factor of safety of the bar is $10\,000/900 = 11$.

The factor of safety was formerly much used in designing, and for timber under steady tension was taken as about 10; that is, one-tenth of the ultimate strength was regarded as the highest allowable unit-stress. By this method, timber having an ultimate tensile strength of 12 000 pounds per square inch should be subjected to a unit-stress of only $12\,000/10 = 1\,200$ pounds per square inch, so that the section area of a stick under a tension of 19 200 pounds should be $19\,200/1\,200 = 16$ square inches.

It is now considered a better plan, in judging of the degree of security of a body under stress, to consider the elastic limit of the material. Thus, for a stick of timber, the elastic limit is about 3 000 pounds per square inch, and the actual unit-stress in tension should be less than this, say one-half or one-third, according as the applied forces are steady or variable. The

method of the factor of safety is, however, of much value to a student and it will be often used in this volume. In practice both ultimate strengths and elastic limits must be considered in deciding upon the allowable unit-stresses to which the parts of engineering constructions are to be subjected. The average values of the ultimate strengths of the materials of engineering are tabulated at the end of this volume in both English and metric measures.

The theoretical and experimental conclusions thus far established, regarding the behavior of a bar under tension or compression, may now be formulated in the following laws:

1. The resisting axial stress in every section of a bar is equal to the applied tensile or compressive load.

2. Under small stresses, the deformations of the bar are proportional to the loads, and hence also to the unit-stresses. When the unit-stress is less than the value called the elastic limit, the bar springs back to its original length on the removal of the load.

3. When the unit-stress is greater than the elastic limit, the deformations increase in a faster ratio than the loads and stresses, and the bar does not spring back to its original length on the removal of the load.

4. When the load becomes sufficiently great, the resisting stress fails to balance it, so that the deformation rapidly increases and the bar ruptures.

5. The allowable unit-stresses used in engineering practice are less than the elastic limit of the material.

The first of these laws is a theoretical one and rigidly correct for all cases, it being in fact a particular case of Newton's law that action and reaction are equal and opposite. The second law applies strictly only to elastic materials like wrought iron and steel, and is only roughly applicable to brittle materials like stone and cast iron. The third law applies to all kinds of materials, but for brittle ones the elastic limit is difficult to determine.

Prob. 3a. A bar of structural steel, $2\frac{1}{2}$ inches in diameter, ruptures under a tension of 271 000 pounds. What is the ultimate tensile strength?

Prob. 3b. Using the value given above for the ultimate tensile strength of cast iron, compute the tensile force which is required to rupture a cast-iron bar which is $2\frac{1}{4} \times 3\frac{1}{8}$ inches in section area.

ART. 4. TENSION

A tensile test of a vertical bar may be made by fastening its upper end firmly with clamps and then applying loads to its lower end. The elongations of the bar are found to increase proportionately to the loads, and hence also to the internal tensile stresses, until the elastic limit of the material is reached (Art. 2). After the unit-stress has exceeded the elastic limit, the elongations increase more rapidly than the loads, and this is often accompanied by a reduction in area of the cross-section of the bar. Finally, the ultimate tensile strength of the material is reached and the bar breaks.

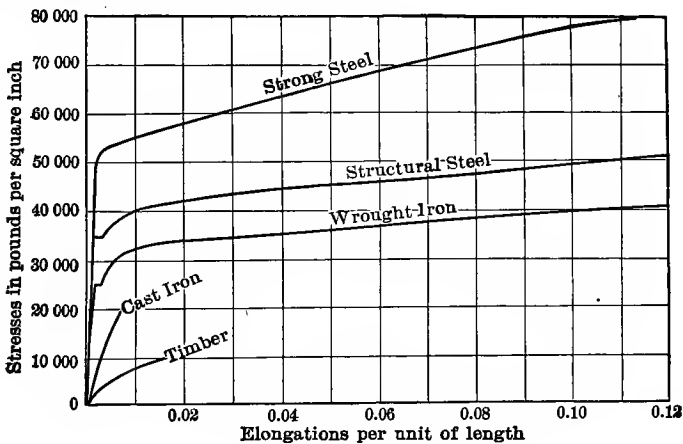

Fig. 4

A graphical illustration of these phenomena may be made by laying off the unit-stresses as ordinates and the elongations per unit of length as the abscissas. At various intervals, as the test progresses, the applied loads are measured and also the corresponding elongations. The load divided by the section area of the bar gives the unit-stress, while the total elongation divided by the length of the bar gives the unit-elongation. On

the diagram a point is put at the intersection of each unit-stress with its corresponding unit-elongation, and a curve is drawn connecting the plotted points. Fig. 4 represents mean curves obtained in this manner for timber, cast iron, wrought iron, and steel. It is seen that each curve is a straight line from the origin until the elastic limit is reached, showing that the unit-elongations increase proportionally to the unit-stresses. At the elastic limit a sudden change in the curve is seen, and afterwards the elongation increases more rapidly than the stress. This diagram gives mean comparative curves only, and the curve for any individual test might deviate considerably from that shown.

The end of the curve marks the rupture of the bar. For example, it is seen that timber ruptures in tension under a stress of about 10 000 pounds per square inch, and that the elongation of the bar at that time is about $\frac{1}{10000}$ of the length of the bar, that is the total elongation is about 1.5 percent of the length. The rupture of wrought iron and structural steel is not shown upon the diagram, since the ultimate elongation of these materials is about 30 percent, while the diagram extends only up to 12 percent. The following are approximate average values of the ultimate strengths and ultimate elongations for five materials widely used in engineering work:

Material	Ultimate Tensile Strength	Ultimate Elongation
Timber	10 000 pounds per square inch	1.5 percent
Cast Iron	20 000 pounds per square inch	0.3 percent
Wrought Iron	50 000 pounds per square inch	30 percent
Structural Steel	60 000 pounds per square inch	30 percent
Strong Steel	100 000 pounds per square inch	15 percent

These ultimate tensile strengths should be carefully kept in mind by the student as a basis for future knowledge, and they will be used in the solution of the examples and problems in this book. Table 3, at the end of this volume, gives values for other materials.

These average values of ultimate strengths and elongations are those derived from tests on small specimens, say one inch in diameter and 8 inches in gaged length. Large bars such as

are used in engineering constructions have ultimate strengths slightly less and ultimate elongations considerably less than these values. One of the reasons for using factors of safety (Art. 3) is to provide security against the smaller ultimate strength of the large pieces which must necessarily be used. The ultimate elongation is an index of the toughness and ductility of the material, but it is not used in the computations of designing. The unit-elongation which occurs when a bar is stressed up to the elastic limit is very small, compared with that which obtains at rupture, as the curves in Fig. 4 plainly show. Fig. 169*a* shows two steel specimens that were ruptured by tension.

Steel is a material which has variable physical properties depending upon its chemical composition and the method of its manufacture. 'Structural steel' is that which is used in buildings, bridges, and ships, and it resembles wrought iron in general behavior, but its tensile strength is about twenty percent higher. 'Strong steel' is not a trade term and is here introduced for instruction purposes only. The grades of steel are very numerous, and they range in tensile strength from 50 000 to 250 000 pounds per square inch. The terms 'soft' and 'hard' are often used to designate steel with low and high tensile strengths.

Prob. 4*a*. A steel specimen, 0.505 inches in diameter, reached the elastic limit under a tensile load of 6 800 pounds and ruptured under a load of 14 800 pounds. Compute the elastic limit and the ultimate strengths of the steel.

Prob. 4*b*. This specimen had a length of 2.00 inches between two marks made on it before the test. At the elastic limit the distance between these two marks was 2.003 inches and after rupture it was 2.45 inches. Compute the unit-elongation for the elastic limit and for rupture.

ART. 5. COMPRESSION

The phenomena of compression are the reverse of those of tension in regard to the direction of the applied forces and resisting stresses. When loads are applied to compress a bar, the amount of shortening is proportional to the load, provided the unit-stress on the material does not exceed the elastic limit. After

the elastic limit is passed, the shortening increases more rapidly than the load and hence more rapidly than the unit-stress, and finally the rupture of the bar takes place. The area of the cross-section decreases under tension and increases under compression.

The simplest way of testing a bar by compression is to place it on a firm foundation and put the load upon its upper face as shown in Fig. 5*a*. The bar is held in equilibrium by the load P and the equal upward reaction of the support and there may be represented by arrows as in Fig. 5*b*. On any horizontal section of the bar, there are acting compressive stresses the sum of which equals P (Art. 1). If the section area is a the average compressive unit-stress is P/a , and this will be uniformly distributed over the section when the forces P coincide in direction with the axis of the prism.

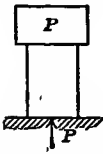
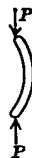
Fig. 5*a*Fig. 5*b*Fig. 5*c*Fig. 5*d*

When the length of the bar does not exceed about ten times its least lateral dimension, rupture sometimes occurs by an oblique splitting or shearing as shown in Fig. 5*c*. When the length is large compared with the thickness, failure occurs under a side-wise bending, as seen in Fig. 5*d*. The short specimens are cases of simple compression, and the values given in the following table refer only to these; the long specimens are called 'columns' and in them other stresses are developed than that of simple compression (Art. 77). In general, the term 'compressive strength' refers to that obtained from a bar the length of which is considerably less than ten times its thickness. Fig. 169*b* shows the rupture of a cement cube and a timber block.

Graphical illustrations of the behavior of materials under compressive stress may be made in the same manner as for tension, the unit-shortenings being laid off as abscissas. In most cases the ultimate shortening is much less than the ultimate

elongation. For steel the elastic limit is about the same in compression as in tension, but the compressive strength of hard steel is much higher than the tensile strength. The following are average values of the ultimate compressive strengths of the principal materials used in engineering construction:

Material	Ultimate Compressive Strength
Brick	3 000 pounds per square inch
Stone	6 000 pounds per square inch
Timber	8 000 pounds per square inch
Cast Iron	90 000 pounds per square inch
Wrought Iron	50 000 pounds per square inch
Structural Steel	60,000 pounds per square inch
Strong Steel	120 000 pounds per square inch

These ultimate strengths are subject to much variation for different qualities of materials, but it is necessary for the student to fix them in his mind as a basis for future knowledge. It is seen that timber is not quite as strong in ultimate compression as in tension, that cast iron is $4\frac{1}{2}$ times as strong, that wrought iron and structural steel have the same strength in the two cases, and that the typical material called strong steel has a higher strength in compression than in tension. There are several varieties of hard steel which have ultimate compressive strengths much greater than that above given (Art. 25).

The investigation of a body under compression is made in the same manner as for one under tension. For example, if a stone block, 8×12 inches in cross-section, is subject to a compression of 230 000 pounds the unit-stress is $230\,000/96 = 2\,400$ pounds per square inch, and the factor of safety is $6\,000/2\,400 = 2\frac{1}{2}$; this is not sufficiently high for stone, as will be seen in Art. 7.

Prob. 5a. A solid cast-iron cylinder of 3 inches diameter is under a compression of 500 000 pounds. Compute its factor of safety.

Prob. 5b. A brick $2 \times 4 \times 8$ inches weighs about $4\frac{1}{2}$ pounds. What must be the height of a pile of bricks so that the compressive unit-stress on the lowest brick shall be one-half of its ultimate strength?

Prob. 5c. A bar of wrought iron one square inch in section area and one yard long weighs 10 pounds. Find the length of a vertical bar so that the stress at the upper end shall equal the elastic limit.

ART. 6. SHEAR

When two equal and opposite forces act at right angles to a bar and are very near together, they are called 'Shearing Forces', and they tend to cut or shear the bar. The action of the forces is similar to those in a pair of shears, from which analogy the name is derived, and the resisting stresses are called 'shearing stresses'. Tension and compression cause stresses which act normally to a section area, but shear causes stresses which act parallel with and along the section area. Unless otherwise stated it is to be considered that the shearing stresses generated by shearing forces are uniformly distributed over the section area.

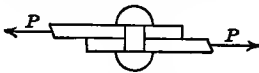

Fig. 6a

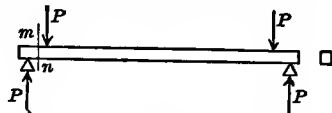

Fig. 6b

Fig. 6a shows the case of two plates fastened together with a rivet and subject to a tension P . Let the section area of the rivet be a ; then the shearing unit-stress on that cross-section lying in the plane where the plates overlap is P/a , and if this equals the ultimate shearing strength of the material, the rivet will rupture by shearing. Fig. 6b shows the case of a beam resting upon two supports and carrying two equal loads P near the supports, the reaction of each support being P ; here a resisting shearing stress equal to P acts on each side of the section mn , the stress on the left of mn acting downward and that on the right acting upward; in this case also the shearing unit-stress is P/a , and the bar will shear off when this is equal to the ultimate shearing strength of the material.

The following are average values of the ultimate shearing strengths of materials as determined by experiment:

Material	Ultimate Shearing Strength
Brick	1 000 pounds per square inch
Stone	1 500 pounds per square inch
Timber, along grain	500 pounds per square inch
Timber, across grain	3 000 pounds per square inch
Cast Iron	18 000 pounds per square inch

Material	Ultimate Shearing Strength
Wrought Iron	40 000 pounds per square inch
Structural Steel	50 000 pounds per square inch
Strong Steel	80 000 pounds per square inch

By comparing these with the values for tension in Art. 4, it is seen that the shearing strength of timber is about one-third of the tensile strength when the shearing occurs across the grain, and very much smaller when it occurs parallel with the grain. For cast iron the shearing strength is about 90 percent, and for wrought iron and steel it is about 80 percent of the tensile strength.

There is an elastic limit in shear as well as in tension and compression, and its value is about one-half of the ultimate shearing strength. When the shearing unit-stress does not exceed the elastic limit, the amount of slipping or detrusion is proportional to the applied force; when it is greater, the deformation increases more rapidly than the force.

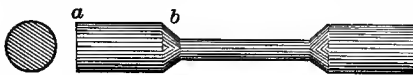

Fig. 6c

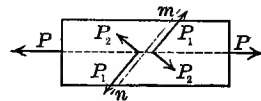

Fig. 6d

Wooden specimens for tensile tests, like that shown in Fig. 6c, will fail by shearing off the ends if their length is not sufficiently great. For example, let ab be 6 inches and the diameter of the central part be $1\frac{1}{2}$ inches. The ends are gripped tightly in the testing machine and the cross-section of the central part thus brought under tensile stress. The load required to cause rupture by tension is,

$$P = aS = 0.7854 \times 1.5^2 \times 10\,000 = 17\,700 \text{ pounds}$$

But the ends may also shear off on the surface of a cylinder having the length ab and a diameter of $1\frac{1}{2}$ inches; the load required to cause this rupture by shearing along the grain is,

$$P = aS = 3.142 \times 1.5 \times 6 \times 500 = 14\,100 \text{ pounds}$$

and hence the specimen will fail by shearing off the ends before the tensile strength of the timber is reached. To prevent this shearing the length ab must be made about 8 inches.

When a bar is subject either to tension or to compression,

a shear occurs in any oblique section. Let Fig. 6*d* represent a bar of section area a subject to the tension P which produces in every normal section the unit-stress P/a . Let mn be a plane making an angle θ with the axis of the bar and cutting from the bar a section having the area a_1 . On the left of the plane, the normal stress P may be resolved into the components P_1 and P_2 , respectively parallel and normal to the plane, and the same may be done on the right. Thus it is seen that the effect of the tensile force on the plane mn is to produce a tension P_2 normal to it and a shear P_1 along it, for the two forces P_1 and P_1 act in opposite directions on opposite sides of the oblique section. The shearing stress P_1 has the value $P \cos\theta$ which is distributed over the area a_1 and this area equals $a/\sin\theta$. Hence the shearing unit-stress along the oblique section is,

$$S_1 = P_1/a_1 = (P/a) \sin\theta \cos\theta = \frac{1}{2}(P/a) \sin 2\theta$$

When $\theta = 0^\circ$ or when $\theta = 90^\circ$, the value of S_1 is zero, that is there is no shear on a plane parallel with or normal to the axis. For all other values of θ , a shearing stress exists; and the maximum value of S_1 occurs when $\theta = 45^\circ$, and then $S_1 = \frac{1}{2}P/a$. Therefore a normal tensile unit-stress S on a bar produces a shearing unit-stress $\frac{1}{2}S$ along every section inclined 45 degrees to the axis of the bar. This investigation applies also to compression and it partially explains why the rupture of compression specimens sometimes occurs by shearing along oblique sections, as indicated in Fig. 5*c*.

Prob. 6*a*. A wrought-iron bolt $1\frac{1}{2}$ inches in diameter has a head $1\frac{1}{4}$ inches long; and a tension of 35 000 pounds is applied longitudinally to it. Compute the tensile unit-stress, and the factor of safety against tension. Compute the unit-stress tending to shear off the head of the bolt, and the factor of safety against shear.

ART. 7. WORKING UNIT-STRESSES

When a bar of section area a is under axial stress caused by a load P , the unit-stress S produced is found by dividing P by a . By comparing this value of S with the ultimate strengths and elastic limits given in the preceding articles, the degree of security of the bar may be inferred. This process is called

investigation. The student may not at first be able to form a good judgment with regard to the degree of security, this being a matter which involves some experience, as well as acquaintance with engineering precedents and practice. As his knowledge increases, however, his ability to judge whether unit-stresses are or are not too great will constantly improve.

When a bar is to be designed to resist an axial load P applied at each end, the unit-stress S is to be assumed in accordance with the rules of practice, and then the section area a is to be computed. Such assumed unit-stresses are often called 'Working Unit-Stresses', meaning that these are the unit-stresses under which the material is to act or work. In selecting them, two fundamental rules are to be kept in mind:

1. Working unit-stresses should be considerably less than the elastic limit of the material.
2. Working unit-stresses should be smaller for sudden loads than for steady loads.

The reason for the first requirement is given in Art. 2. The reason for the second requirement is that experience teaches that suddenly applied loads and shocks are more injurious and produce larger deformations than steady loads. Thus, a bridge subject to the traffic of heavy trains must be designed with lower unit-stresses than a roof where the variable load consists only of snow and wind. In buildings the stresses are mostly steady, in bridges they are variable, and in machines the stresses are often produced with shock.

It will be best for the student to begin to form his engineering judgment by fixing in mind the following average values of the factors of safety to be used for different materials under different circumstances:

Material	Steady Stress	Variable Stress	Shocks
Brick and Stone	15	25	40
Timber	8	10	15
Cast Iron	6	10	20
Wrought Iron	4	6	10
Structural Steel	4	6	10
Strong Steel	5	8	15

The working unit-stress will then be found for any special case by dividing the ultimate strengths by these factors of safety. For instance, a short timber strut in a bridge should have a working unit-stress of about $8000/10 = 800$ pounds per square inch.

It is usually the case that a designer works under specifications in which the unit-stresses to be used are definitely stated. The writer of the specifications must necessarily be an engineer of much experience and with a thorough knowledge of the best practice. The particular qualities of timber or steel to be used will influence his selection of working unit-stresses, and in fact different members of a bridge truss are often designed with different unit-stresses. The two fundamental rules above given are, however, the guiding ones in all cases. In Table 5, at the end of this volume, will be found the working unit-stresses which are specified in the building code of the City of New York. These apply in the design of buildings, and the unit-stresses to be used in the design of bridges are lower than those in the table, while those to be used in the design of machines should be lower still.

The two fundamental principles of engineering design are stability and economy, or in other words:

1. A structure must safely withstand all the stresses which may be caused by loads that can come upon it.
2. A structure should be designed so that it may be built and maintained at the lowest possible cost.

The second of these fundamental principles requires that all parts of the structure should be of equal strength, like the celebrated 'one-hoss shay' of the poet. For, if one part is stronger than another, it has an excess of material which might have been saved. Of course this rule is to be violated when the cost of the labor required to save the material is greater than that of the material itself. Thus it often happens that some parts of a structure have higher factors of safety than others, but the lowest factors should not be less than those which good engineering practice requires.

The factors of safety stated above may be supposed to be so arranged that, if different materials are united, the stability

of all parts of the structure will be the same, so that if rupture occurs, everything would break at once. Or, in other words, timber with a factor of safety 8 has about the same reliability as steel with a factor of 4 or stone with a factor of 15, provided the stresses are due to steady loads.

As an example of design, let it be required to determine the size of a short piston-rod made of hard steel having an ultimate tensile strength of 75 000 pounds per square inch, the piston being 20 inches in diameter and the steam pressure upon it being 80 pounds per square inch. This being a rod subject to rapidly alternating stresses of tension and compression and perhaps to shocks, the factor of safety should be taken at 15, which gives a working unit-stress of $75\,000/15 = 5\,000$ pounds per square inch. The total tension being $0.7854 \times 20^2 \times 80 = 25\,100$ pounds, the area of the cross-section should be $25\,100/5\,000 = 5.03$ square inches and this will be furnished by a rod 2.53 inches in diameter, so that a diameter of $2\frac{1}{2}$ inches will probably be sufficient to give proper security against tension. Since the compressive strength of hard steel is higher than the tensile strength, and since the rod is short, this diameter also gives proper security against compression.

Prob. 7a. A rod of structural steel is to be used under a tension of 87 000 pounds. Compute its diameter when it is to be used in a building, and also when it is to be used in a bridge.

Prob. 7b. In Fig. 6b each of the loads is 4 700 pounds and the wooden beam is 2×3 inches in cross-section. Compute the factor of safety against shearing. Is this factor sufficiently high for steady loads?

ART. 8. COMPUTATIONS AND EQUATIONS

The numerical computations required in the mechanics of materials should be performed so that the precision of the results fairly corresponds with the precision of the data. The values of the elastic limits and ultimate strengths given in the preceding tables are indefinite in the second significant figure and hence computed areas should not be carried further than three sig-

nificant figures the last of which has no precision. For instance in the area of 5.03 square inches computed at the end of the last article the last figure is of no importance, since the working unit-stress of 5 000 pounds per square inch is derived from rough data. Numerical computations, therefore, should include only three significant figures as a general rule.

At the end of this volume are given tables of four-place logarithms, squares of numbers, and areas of circles which are of value in abridging computations. The table of squares may be used to find square roots, and the table of circles to find diameters from given areas. For example, a circle having an area of 0.82 square inches has a diameter of 1.02 inches; a circle having an area of 8.2 square inches has a diameter of 3.23 inches.

As this book is mainly intended for the use of students in engineering colleges, a word of advice directed especially to them may not be inappropriate. It will be necessary for students, in order to gain a clear idea of the mechanics of materials, or of any engineering subject, to solve many numerical problems, and in this work a neat and systematic method should be followed. The practice of making computations on any loose scraps of paper that may happen to be at hand should be discontinued by every student who has followed it, and he should hereafter solve his problems in a special book provided for that purpose, accompanying them by explanatory remarks. Such a notebook, written in ink, and containing the solutions of the problems given in these pages will prove of great value to every student. Before beginning the solution of a problem, a diagram should be drawn whenever possible, for a diagram helps the student to understand the problem, and a problem thoroughly understood is half solved. Before beginning the numerical work, it is also well to make a mental estimate of the answer and record the same, comparing it later with the result of the solution, since in this manner the engineering judgment of the student will be developed.

In continental Europe the metric system is universally employed in the mechanics of materials, the unit of force or stress being

the kilogram, that of length being the meter or centimeter, and that of area being the square centimeter. Computations in the metric system are much simpler than those in the English system, and it is to be hoped that the time is not far distant when it will come into general use. As a slight contribution to this end, the average constants relating to the strength of materials are given in metric units in Tables 1-4 at the end of this volume, and a few problems using such units will be occasionally proposed. In solving these problems the student should think in the metric system and make no transformations of the data or the results into the English system. The table of areas of circles at the end of this volume is applicable to all systems of measures.

In the English system of measures, as generally used in this volume, the unit of force is the pound, the unit of length is the inch, and the unit of area is the square inch. Lengths of bars and beams are sometimes stated in feet, but these should be reduced to inches when they are to be used in formulas in order that they may be consistent with the other data.

In this volume Greek letters are used only for signs of operation, for abstract numbers, and for angles. The letter δ is employed as the symbol of differentiation and Σ as the symbol of summation; the Greek names of these two letters should not be used, but they may be called 'differential' and 'algebraic sum'. The following are the names of other Greek letters:

α Alpha,	β Beta,	ϵ Epsilon,	η Eta,
θ Theta,	κ Kappa,	λ Lambda,	μ Mu,
ν Nu,	π Pi,	ρ Rho,	σ Sigma,
τ Tau,	ϕ Phi,	ψ Psi,	ω Omega.

In every algebraic equation it is necessary that all of the terms should be of the same dimension, for it is impossible to add together quantities of different kinds. This principle will be of great assistance to the student in checking the correctness of algebraic work. For example, let a and b represent areas and l a length; then such an equation as $al - l^2 = b$ is impossible, because al is a volume while l^2 and b are areas. Again, let S represent pounds per square inch, P pounds, l inches, and a

square inches; then the equations $S=P/a$ and $P=aS$ are correct with respect to dimensions, but the equation $S^2l^2/P=a$ is impossible because the first member represents pounds per square inch while the second is an area. The equation $S_1 = \frac{1}{2}(P/a) \sin 2\theta$, deduced in Art. 6, is correct in dimensions, for both S_1 and P/a represent pounds per square inch while $\sin 2\theta$ is an abstract number.

Prob. 8a. A bar of wrought iron is 3.25 centimeters in diameter. What load in kilograms will cause it to rupture by tension? What load will stress it up to one-half of the elastic limit?

Prob. 8b. A round bar of structural steel is under a tension of 7 000 kilos. What should be its diameter in centimeters in order that the factor of safety may be 6?

Prob. 8c. Let K represent work, P pounds, S and E pounds per square inch, l inches, and a square inches; determine whether or not the formula $K = \frac{1}{2}(S^2/E)al$ is dimensionally correct. Also show whether the equation $x^5 + px^3 + qx + pq = 0$ is or is not correct.

CHAPTER II

ELASTIC AND ULTIMATE DEFORMATION

ART. 9. MODULUS OF ELASTICITY

The term 'Elastic Deformation' is used to designate that change of shape of a body which accompanies stresses that do not surpass the elastic limit of the material. In tension the principal deformation is the elongation of the bar, in compression it is the shortening. The fact that these deformations are proportional to the stresses (Art. 2) enables rules to be established whereby the change of length of a bar can be computed, provided the elastic limit be not exceeded.

Let P be an axial tensile load applied to a bar which has a cross-section of area a ; then the tensile unit-stress S is P/a (Art. 1). Let l be the length of the bar and e the total elongation which occurs under the stress; then the unit-elongation is e/l , and this will be designated by ϵ . Similarly let P be a compressive load which produces the shortening e , the compressive unit-stress is P/a , and the unit-shortening is e/l . Unit-stress is the stress on a unit of area, the total stress being regarded as uniformly distributed over the section area of the bar. Unit-deformation is the change in length of a linear unit of the bar, the total deformation being regarded as uniformly distributed over the total length. Accordingly for any bar in tension or compression,

$$\text{Unit-stress } S = P/a \qquad \text{Unit-deformation } \epsilon = e/l$$

and these are applicable whether the elastic limit be exceeded or not, as illustrated in Art. 4.

When the elastic limit is not exceeded by the unit-stress, the unit-deformation e/l is proportional to the unit-stress P/a , and hence the ratio of the latter to the former is a constant for each kind of material. The term 'Modulus of Elasticity' is used for this constant, and it may be defined as the ratio of the unit-stress

to the unit-deformation. The letter E is used for the modulus of elasticity and hence, from the definition, its value for tension or compression is,

$$E = \frac{S}{\epsilon} \quad \text{or} \quad E = \frac{P/a}{e/l} \quad (9)$$

Since e and l are linear quantities, ϵ is an abstract number, and therefore E is expressed in the same unit as S , that is in pounds per square inch or in kilograms per square centimeter.

The above equations show that E equals P when a is unity and e is equal to l ; that is, the modulus of elasticity is the force which will elongate a bar of one square unit in cross-section to double its original length, provided that this can be done without exceeding the elastic limit of the material. There is probably no material, except india-rubber, for which so great an elastic elongation is possible.

The modulus of elasticity E is called by some writers the 'coefficient of elasticity', but the former term is now of more general use in the United States of America; in books on physics it is often called 'Young's modulus'. The student should carefully note that the above formulas for E apply only when the unit-stress S or P/a is less than the elastic limit of the material. When modulus of elasticity is mentioned without qualification, it is always understood to refer to tension or compression and not to shear (Art. 15).

When gradually increasing loads are applied to a bar and the values of e are measured for different values of P , the simultaneous quantities P/a and e/l are known, and their ratio gives the value of E . The following are approximate average values of E for the different materials used in engineering construction, which have been derived from the records of numerous tests:

Material	Modulus of Elasticity
Brick	2 000 000 pounds per square inch
Stone	6 000 000 pounds per square inch
Timber	1 500 000 pounds per square inch
Cast Iron	15 000 000 pounds per square inch
Wrought Iron	25 000 000 pounds per square inch
Steel	30 000 000 pounds per square inch

The values here given for brick and stone apply only to compression and little is known regarding the elastic properties of these materials under tension; those given for the other materials apply to both tension and compression. It is seen that the modulus of elasticity for timber is one-tenth of that for cast iron, that for cast iron being one-half of that for steel. Table 2, at the end of this book, gives these constants in metric measures.

The modulus of elasticity is a measure of the stiffness of the material, that is, of its ability to resist change of shape under unit-stresses not higher than the elastic limit. For, the unit-deformation ϵ may be expressed by S/E , and hence ϵ is the least for a given S when E is the greatest. The above values of E show that the elastic change in length of a steel bar is one-twentieth of that of a timber bar and one-half of that of a cast-iron bar, the applied tension being the same in the three cases and the sizes and lengths of the bars being equal.

Prob. 9a. Compute the modulus of elasticity of a bar, $1\frac{1}{4}$ inches in diameter and 16 feet long, which elongates 0.125 inches under a tension of 21 000 pounds.

Prob. 9b. A wooden specimen 1 inch in diameter and 18 inches long, elongates 0.013 inches when the tension is increased from 800 to 1 600 pounds, and 0.24 inches when the tension is increased from 1 600 to 6 000 pounds. Compute the modulus of elasticity.

ART. 10. ELASTIC CHANGE IN LENGTH

The change in length of a bar under an axial stress which does not exceed the elastic limit of the material is readily computed when the modulus of elasticity of the material is known. From the definition of that modulus in Art. 9, it is seen that the unit-deformation in length is $\epsilon = S/E$, and that the total deformation in length is

$$e = \frac{S}{E}l \quad \text{or} \quad e = \frac{P/a}{E}l = \frac{Pl}{aE} \quad (10)$$

in which e is the change in the length l , and P/a or S is the unit-stress, while E is the modulus of elasticity. If e is to be found in inches, then l must be in inches; S and E are in pounds per

square inch and hence their ratio is an abstract number. When S is a tensile unit-stress, e is the elongation of the bar; when S is a compressive unit-stress, e is the shortening of the bar.

These formulas may be used for computing the change of length which occurs at the elastic limit, or under any value of S less than the elastic limit. Using the mean values of the elastic limits in Art. 2 and those of E in Art. 9, the following values of e/l are found for tension:

For timber,	$e/l = 1/500 = 0.0020$
For cast iron,	$e/l = 1/2500 = 0.0004$
For wrought iron,	$e/l = 1/1000 = 0.0010$
For structural steel,	$e/l = 1/850 = 0.0012$

These quantities show that, when bars of the same length are stressed up to their elastic limits, the elongation of the cast-iron bar is the least, that of wrought iron next, and that of timber the greatest. The ultimate elongations, namely those which obtain at rupture, follow a different order and are very much greater than those which occur at the elastic limit.

As an example for stresses within the elastic limit, let it be required to find the elongation of a bar of steel, $1\frac{1}{2} \times 12$ inches in section area and 23 feet long, when under a tension of 270 000 pounds. The unit-stress under this tension is $S = 270\ 000/18 = 15\ 000$ pounds per square inch, and as this is less than the elastic limit the formula applies, and $e = 15\ 000 \times 276/30\ 000\ 000 = 0.138$ inches. This would also be the amount of shortening of the bar under a compression of 270 000 pounds, provided that no lateral bending occurred, but it will be seen later that a bar of this size and length is unable to withstand a unit-stress as high as 15 000 pounds per square inch on account of the sidewise flexure. The above formulas can in general be used only for finding the shortening of a bar in compression when its length is less than twenty times its thickness.

From the formula $e/l = (P/a)/E$, which applies to all elastic changes of length, any one of the five quantities may be computed when the other four are given. For example, the unit-elongation of timber when it is stressed up to one-half of its

elastic limit is found by $e/l = 1500/1\ 500\ 000 = 1/1\ 000$, so that if a stick of timber elongates 0.48 inches, its length is $l = 0.48 \times 1\ 000 = 480$ inches = 40 feet. Should it be required to find the elongation of a bar of wrought iron, $1\frac{3}{8}$ inches in diameter and 16 feet long, under a tension of 51 000 pounds, the section area is 1.485 square inches, and the unit-stress $S = 51\ 000/1.485 = 34\ 300$ pounds per square inch; as this is greater than the elastic limit of the material, the formula has no validity and it is impossible to compute by it the value of the elongation.

Prob. 10*a*. Compute the elongations of a wrought-iron bar, $1\frac{1}{8}$ inches in diameter and 24 feet long, under tensions of 10 000, 20 000, and 30 000 pounds.

Prob. 10*b*. Compute the tensile force required to stretch a bar of structural steel, $1\frac{3}{4} \times 9\frac{3}{4}$ inches in section area and 23 feet $3\frac{1}{8}$ inches long, so that its length may be increased to 23 feet $5\frac{7}{8}$ inches.

ART. 11. ELASTIC LIMIT AND YIELD POINT

In Art. 2 the elastic limit was defined as that unit-stress within which the deformation of a bar is proportional to the stress and beyond which the deformation increases in a more rapid ratio than the stress. The diagram in Art. 4 illustrates these experimental facts for tension, the relation between unit-stress and unit-elongation being shown by a straight line until the elastic limit is reached and afterwards by a curve. The point where the straight line is tangent to the curve indicates the elastic limit of the material.

In Fig. 11*a* there is given, on a larger horizontal scale, a part of the tension diagram of Fig. 4. For each material the point of elastic limit is marked by a dash normal to the curve. For any unit-stress S less than the elastic limit, the ratio of S to the unit-deformation ϵ is a constant, or $S/\epsilon = E$, and E is the modulus of elasticity of the material. The greater the inclination of the straight line to the horizontal, the greater is the value of E . Since ϵ and S are variable rectangular coordinates, the equation

$S = E\epsilon$ is that of a straight line and E is the tangent of the angle which this line makes with the horizontal.

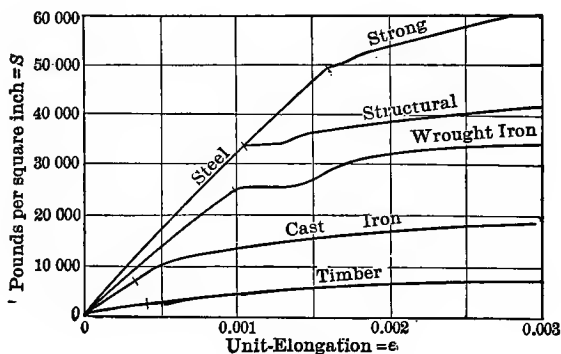

Fig. 11a

Another definition of the elastic limit is that it is the unit-stress within which the bar returns to its original length, when the load is removed, and beyond which it does not fully return, a part of the deformation being permanent. The term 'limit of elasticity' is sometimes used instead of elastic limit when considering the subject from this point of view. Fig. 11b shows a part of the tensile diagram for wrought iron in which AB represents a bar of unit length which is stretched to the lengths AB' , AC' , and AD' under stresses of 25 000, 30 000, and 34 000 pounds per square inch. If the tension is removed when the stretch is less than BB' the bar springs back to its original length AB ; here $B'b$ is the elastic limit of the material. If the tension is removed when the bar has the stretch BD' , the bar springs back to D so that its length is AD and it has the permanent set BD . Similarly for any length AC the bar under tension has the stretch BC' and, on the removal of the tension, it springs back to the length AC and has the permanent set BC . It has been found by many experiments that the lines Cc and Dd are nearly straight and closely parallel to the line Bb .

An inspection of Figs. 11a and 11b shows that it is more difficult to locate the point of tangency on the lines for timber and cast iron than on those for wrought iron and structural steel.

In other words the elastic limits in tension for timber and cast iron are not well defined. On the compression diagram it is also seen that the elastic limits for wrought iron and structural steel are not so sharply defined as those for tension, although they are more determinable than for the other materials.

The 'Yield Point' is defined to be that unit-stress at which the deformation increases without any increase in applied load or in internal stress. In Fig. 11a it is seen that the lines for wrought iron and structural steel curve beyond the elastic limit for a short distance and then become horizontal. In Fig. 11b the point where the curve becomes horizontal is marked by the letter b' , and the unit-stress corresponding to this is called the yield point. Only ductile materials like wrought iron and structural steel have yield points and these generally belong to tension and are usually only observed in testing machines where the tension is slowly applied. Beyond the yield point the curve continues horizontal for a short distance and then gradually rises.

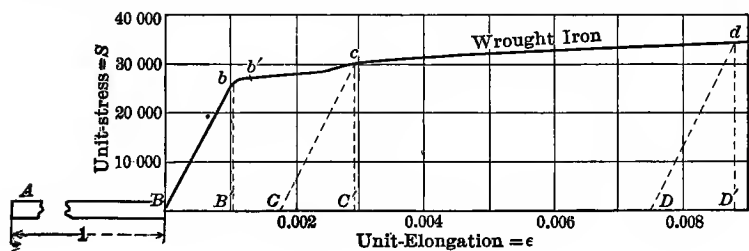

Fig. 11b

In commercial testing the yield point is sometimes called the elastic limit because the former is more easily ascertained than the latter (Art. 25). This is an improper use of the term elastic limit which should be avoided. For structural steel the yield point is often higher than the elastic limit by from 3 000 to 6 000 pounds per square inch, and hence it is important that the distinction should be carefully observed.

- Prob. 11. Bars of cast iron, wrought iron, and steel, 1 square inch in section area and 100 inches long, are subject to a tension of 15 000 pounds. Determine the elongation of each bar from Fig. 11a. Also compute the elongations, as far as possible, from the rules of Art. 10.

ART. 12. ULTIMATE DEFORMATIONS

Mean values of the ultimate unit-elongations for different materials are given in the table of Art. 4, and the stress diagrams in Fig. 4 show that these are large compared with that which occurs at the elastic limit. Timber and cast-iron bars have ultimate elongations about 8 times as great as the elastic elongations, while steel has ultimate elongations from 100 to 300 times as great as the elastic ones. There is no method by which the ultimate elongation of a bar can be computed, but all knowledge concerning it must be derived from the records of tests.

The ultimate elongation of a bar is determined by making two marks upon it before it is subjected to tension and measuring the distance between them before and after the test. The difference of these lengths divided by the original length gives the ultimate elongation per unit of length, that is, the unit-elongation. For example, if the distance between the two marks is 2.01 inches and if this becomes 2.57 inches after the rupture, then the total elongation is $2.57 - 2.01 = 0.56$ inches, and the ultimate unit-elongation is $0.56/2.01 = 0.280$ or 28.0 percent.

In Fig. 169*a* are shown three steel specimens, that at the top being one which has not been tested. Its total length is $5\frac{1}{4}$ inches and about $2\frac{1}{2}$ inches of the central part is one-half an inch in diameter. The marks are placed on this cylinder about 2 inches apart, the exact distance being measured to the nearest hundredth of an inch. The two other specimens have been ruptured by tension applied through the screw ends by the testing machine, and the respective elongations were found to be 3.8 and 22.5 percent. This great difference in the ultimate elongation of steel may be due to differences in chemical composition and method of manufacture, but in this case it was largely due to a flaw in the ruptured section of the middle specimen. The loads that ruptured these two specimens were 18 600 and 22 000 pounds respectively, so that the ultimate strengths were about 83 000 and 110 000 pounds per square inch.

An elongation of a bar is always accompanied by a reduction in the area of its cross-section. The greater the ultimate elongation the less is the area of the ruptured section. For ductile materials, like wrought iron and some kinds of steel, there is observed a very marked change, as the ultimate strength is approached, on both sides of the section where rupture is about to occur. In Fig. 169*a* this is scarcely observable in the middle specimen, but it is plainly seen in the lower one.

The term 'Reduction of Area' refers to a ruptured specimen and means the diminution in section area per unit of original area. Thus for the third specimen, the original section area was 0.1995 square inches, the area of the ruptured section was 0.1064 square inches, and hence the reduction of area is $0.0931/0.1995 = 0.467$, or 46.7 percent. Instead of actually computing the area, the squares of the diameters may be used; thus, the original diameter was 0.504 inches, the diameter of the ruptured section was 0.368 inches, and the squares of these are 0.2540 and 0.1354; the reduction of area is then $0.1186/0.2540 = 46.7$ percent. Reduction of area, or contraction of area as it is often called, is an index of the ductility of the material, and it is generally regarded as a more reliable index than elongation, because the ultimate unit-elongation is subject to variation with the ratio of the length of the specimen to its diameter, whereas the reduction of area is more constant. In Art. 169 further remarks regarding ultimate elongation will be found.

Under compression, a cube or a prism decreases in length and the area of its cross-section increases with the amount of shortening. The ultimate shortening is, however, rarely determined, and in most cases it is much less than the ultimate elongation in tension. The rupture of the compression specimen, having a length of less than ten times its least lateral dimension, occurs usually by an oblique shearing which is illustrated in Fig. 5*c* and which will be discussed later (Art. 147).

When a bar is under tension exceeding its elastic limit, and this is released by the removal of the load, the length of the bar is greater than before, as shown in the last article. It is impos-

sible to compute this new length, but the amount of change after the removal of the tension can be ascertained when the modulus E is known. In Fig. 11*b* let the unit-stress $D'd$ be represented by S ; then, since dD is parallel to bB , the tangent of the angle dDD' is the modulus E , and hence on the removal of the tension the change in unit-elongation is $DD' = S/E$. Thus, if a bar of structural steel 20 feet long is stressed in tension up to 45 000 pounds per square inch, it will shorten, when the stress is released, the amount $240 \times 45\ 000 / 30\ 000\ 000 = 0.36$ inches.

Although the area of the cross-section decreases under tension and increases under compression, the unit-stress S is always obtained by dividing the load P by the original area a . This is perhaps not strictly correct, but it is the custom in practice, and all stress diagrams are constructed by using unit-stresses computed in this manner.

Prob. 12. Test specimen No. 7478 of the Watertown Arsenal was 0.798 inches in diameter and 6 inches long between marks. After rupture the distance between marks was 7.44 inches, and the diameter of the ruptured section was 0.64 inches. Compute the percentages of ultimate elongation and reduction of area.

ART. 13. CHANGES IN SECTION AND VOLUME

When the unit-stress does not exceed the elastic limit, the changes in the area of the cross-section and in the volume of a body under stress are very small, but it is possible to compute them approximately as shown below. When the unit-stress exceeds the elastic limit, there is no method by which changes in section and volume can be computed.

Many measurements of the lateral dimensions of bars under normal stress have proved that their elastic change is proportional to the linear unit-deformation. Thus, let a bar of length l and diameter d have the unit-elongation ϵ ; its increase in length is ϵl and its decrease in diameter is $\lambda \epsilon d$, where λ is a number which has been found to be about $\frac{1}{4}$ for cast iron and about $\frac{1}{3}$ for steel. For example, the value of ϵ for wrought iron stressed

to its elastic limit is about 0.001 (Art. 10), so that the change in length of the bar then is $0.001l$, while the change in its diameter is $\frac{1}{3} \times 0.001d$.

Let h be any lateral dimension of length l , and let h' and l' be the lateral dimension and length under a stress which does not exceed the elastic limit of the material; then for tension,

$$l' = (1 + \epsilon)l \quad \text{and} \quad h' = (1 - \lambda\epsilon)h \quad (13)$$

and similarly for the case of compression,

$$l' = (1 - \epsilon)l \quad \text{and} \quad h' = (1 + \lambda\epsilon)h \quad (13)'$$

in which the linear unit-deformation ϵ may be computed from $\epsilon = S/E$ (Art. 9). The number ϵ is very small compared with unity, and hence its square and higher powers may be neglected when they occur in algebraic work.

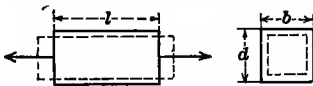

Fig. 13a

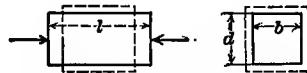

Fig. 13b

Let a bar of rectangular section have the breadth b and the depth d ; the area of the section is bd . Under elastic tension, b becomes $(1 - \lambda\epsilon)b$ and d becomes $(1 - \lambda\epsilon)d$, so that the area of the section is $(1 - 2\lambda\epsilon)bd$, and hence the decrease in area is $2\lambda\epsilon bd$, or $2\lambda\epsilon$ is the decrease per unit of area. For example, let a bar of structural steel of 16 square inches cross-section be stressed in tension up to 27 000 pounds per square inch; then $\epsilon = 27\ 000/30\ 000\ 000 = 0.0009$ and, since λ is $\frac{1}{3}$, the decrease in unit-area is 0.0006, so that the area of the section under this stress is $16 - 0.0006 \times 16 = 15.99$ square inches. Fig. 13a illustrates the change in shape for this case.

The elastic change in volume of a rectangular bar under tension is found in a similar manner. The length l increases to $(1 + \epsilon)l$, the breadth b decreases to $(1 - \lambda\epsilon)b$, the depth d decreases to $(1 - \lambda\epsilon)d$, so that the original volume lbd becomes

$$(1 + \epsilon)l \cdot (1 - \lambda\epsilon)b \cdot (1 - \lambda\epsilon)d = (1 + \epsilon - 2\lambda\epsilon)lbd$$

This expression shows that the volume of a bar under tension

is increased when λ is less than $\frac{1}{2}$ and this is the case for all materials used in construction. The increase in unit-volume is $(1-2\lambda)\epsilon$, which becomes $\frac{1}{2}\epsilon$ for cast iron and $\frac{1}{3}\epsilon$ for wrought iron and steel; that is, the increase per unit of volume is one-half or one-third of the elongation per unit of length.

In neglecting the squares and higher powers of ϵ no error appreciable in practice has been committed, as the student may easily see by numerical instances. Thus, the square of $(1+0.001)$ is 1.002 by the approximate method, while its exact value is 1.002001. If ν is a small number compared with unity, then $(1+\nu)^2=1+2\nu$ and $(1+\nu)^{\frac{1}{2}}=1+\frac{1}{2}\nu$; also $1/(1+\nu)=1-\nu$, and $1/(1-\nu)=1+\nu$. Again, if ν and μ be small compared with unity, then $(1+\nu)(1+\mu)=1+\nu+\mu$ and $(1+\nu)(1-\mu)=1+\nu-\mu$; also $(1+\nu)^2(1-2\mu)^2=1+2\nu-4\mu$. This principle of neglecting squares and cubes is often of great value in approximate numerical computations; thus $(1.02)^2=1.04$, and $0.994^2=(1-0.006)^2=1-0.012=0.988$; also $(0.994)^{\frac{1}{2}}=(1-0.006)^{\frac{1}{2}}=1-0.003=0.997$.

In a similar manner it is readily shown that a bar of length l , breadth b , and depth d under compression in the direction of its length, has the area of its section increased by $2\lambda\epsilon bd$, and its volume diminished by $(\epsilon-2\lambda\epsilon)lbd$, when ϵ is the unit-shortening of length under a stress not exceeding the elastic limit of the material; Fig. 13*b* illustrates this case.

The number λ is called the 'Factor of Lateral Contraction' and sometimes also 'Poisson's Ratio'. It is of great theoretic importance in many discussions of the mechanics of materials, and of great practical value in the manufacture of guns.

Prob. 13*a*. Multiply together the numbers 0.989, 1.012, 1.005 by the above approximate method, and find the percentage of error in the result.

Prob. 13*b*. A bar of structural steel, $2\frac{1}{2}$ inches in diameter and 18 feet 6 inches long, is under a tension of 64 000 pounds. Compute the changes in length, section area, and volume.

Prob. 13*c*. A bar of wrought iron is one square centimeter in section area and one meter long. Compute its length and section area when stressed to its tensile elastic limit.

ART. 14. WORK IN PRODUCING DEFORMATION

When a bar is to be put under tensile stress, the load is applied by weights added in succession, or by means of a pull exerted by a machine. In both cases the tension increases from 0 up to P , and the elongation of the bar increases from 0 up to e . When the elastic limit is not exceeded, the elongations are proportional to the applied forces, and the relation between them may be represented by a straight line as in Fig. 14a. The work done in elongating the bar is then the product of the mean force $\frac{1}{2}P$ into the distance e , or $\frac{1}{2}Pe$, and this is represented in the figure by the area of the shaded triangle.

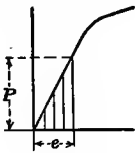

Fig. 14a

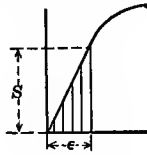

Fig. 14b

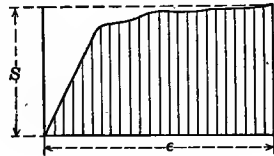

Fig. 14c

Let a be the section area of the bar and l its length, S the tensile unit-stress and ϵ the unit-elongation; then $P = aS$, and $e = \epsilon l$, and inserting these in $\frac{1}{2}Pe$ it becomes $\frac{1}{2}S\epsilon \cdot al$, which is the work done in elongating the bar up to the unit-stress S . Since al is the volume of the bar, $\frac{1}{2}S\epsilon$ is the work done per unit of volume; in Fig. 14b this work is represented by the area of the shaded triangle.

The above investigation applies equally well to the case of compression. Hence, in any case of direct tension or compression, the work K of elastic deformation is,

$$K = \frac{1}{2}Pe \quad \text{or} \quad K = \frac{1}{2}S\epsilon \cdot al \quad (14)$$

both of which apply when the unit-stress S is not greater than the elastic limit of the material. This work is stored in the bar in the form of potential stress energy.

As an example, let it be required to find what horse-power engine is required to produce, 1 200 times per minute, a tension of 56 000 pounds in a steel rod which is 3 inches in diameter and 68 inches long. From Table 16 the section area is 7.07

square inches; from Art. 1 the tensile unit-stress is 7 920 pounds per square inch; from Art. 10 the unit-elongation ϵ is 0.000 264. Then from (14) the work done in one application of the load is $\frac{1}{2} \times 7920 \times 0.000264 = 1.045$ inch-pounds for each cubic inch of the rod, and the total work is therefore $1.045 \times 7.07 \times 68 = 502$ inch-pounds. The horse-power required to do this work is then $502 \times 1200 / 12 \times 33\ 000 = 1.53$.

When the unit-stress exceeds the elastic limit of the material, the above formulas are not valid. In such cases, however, the work done per unit of volume is given by the shaded area of the stress diagram in Fig. 14c. This area may be approximately ascertained by dividing it into trapezoids and computing the separate areas. The work done in stressing a steel bar up to its ultimate strength is large compared with that required to stress it up to its elastic limit, being sometimes more than five hundred times as large.

In order to show this fact, the particular case of a steel specimen 4 inches long and 0.505 inches in diameter will be taken.

Load Pounds	Remarks	Stress Pounds per Square inch	Elongation Percents.	Partial Work Inch-pounds per Cubic Inch	Total Work Inch-pounds per Cubic Inch	
200	Initial Load	1 000	0.00		0	
1 000		5 000	0.01	0.3	0	
3 000		15 000	0.04	3.0	3	
5 000		25 000	0.07	6.0	9	
7 000		35 000	0.10	9.0	18	
9 000		45 000	0.14	16.0	34	
9 600		Elastic Limit	48 000	0.16	9.3	44
10 000			50 000	0.70	264.6	308
12 000			60 000	1.90	660.0	968
14 000	70 000		3.62	1 120.0	2 088	
16 000	80 000		8.50	3 660.0	5 748	
16 800	Ultimate Strength	84 000	15.20	5 494.0	11 242	
15 000		Rupture	75 000	24.50	7 383.0	18 625

The specimen was placed in a testing machine and the elongations measured corresponding to the loads in the first column. From these elongations e the unit-elongations e/l were com-

puted and the values of $100e/l$ are the percentages of elongation in the fourth column, while the loads divided by the section areas give the unit-stresses in the third column. The elastic limit was observed at 48 000 pounds per square inch with 0.16 percent elongation. The elongation then rapidly increased with the load, as seen in the diagram of Fig. 4. At 84 000 pounds per square inch the maximum tensile strength was reached and the specimen was elongating rapidly. The load was then slowly slackened, but the elongation continued to increase very fast until rupture occurred at 75 000 pounds per square inch. The work done per cubic inch of material may be approximately computed for any interval by multiplying the average unit-stress during that interval by the unit-elongation which occurs. Thus while the load ranged from 7 000 to 9 000 pounds the average unit-stress was 40 000 pounds per square inch, and the unit-elongation was $0.0014 - 0.0010 = 0.0004$; hence the work per cubic inch of material was $40\,000 \times 0.0004 = 16$ inch-pounds. Thus the quantities in the fifth column of the table are computed and the summation of these gives those in the last column.

This example shows that the work done on the specimen in stressing it up to the elastic limit was 44 inch-pounds, while the total work required to rupture it was about 18 600 inch-pounds, both being per cubic inch of material. The volume of the specimen being 0.8 cubic inches, the approximate work required to rupture it was 14 900 inch-pounds or 1 240 foot-pounds.

Prob. 14a. Compute the work per cubic inch which is done in stressing cast iron, wrought iron, and structural steel up to their elastic limits.

Prob. 14b. How many foot-pounds of work are required to stress a wrought-iron bar, 4 inches in diameter and 54 inches long from 6 000 pounds per square inch up to 12 000 pounds per square inch?

ART. 15. SHEARING MODULUS OF ELASTICITY

Let a body of constant cross-section and length l be subject to shearing as shown in Fig. 15, the length l being short, so that the rectangle $ABCD$ is deformed into the rhombus $ABC'D'$.

This deformation is caused by the force P acting at C normal to BC , while the body is firmly held at AB so that the points A and B remain immovable. Along AB there then acts a force equal to that at C but in the opposite direction, and the body is under shear from the action of these two forces (Arts. 1 and 6). The deformation CC' , generally called the "detrusion", may be represented by e , and the detrusion per unit of length is then e/l .

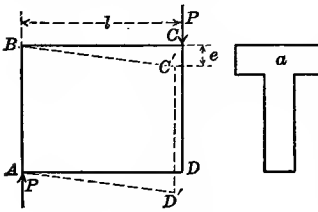

Fig. 15

In tension and compression the deformation e is in the same direction as l , but in shear it is normal to l .

Let a be the section area of the short bar; then the shearing unit-stress on it is $S_s = P/a$. In tension and compression this stress acts normal to the section, but here it is parallel to the section. If the elastic limit of the material is not exceeded by the unit-stresses, the unit-detrusions are proportional to them, so that the ratio of P/a to e/l is a constant, and this constant is called the 'Modulus of Elasticity for Shear'. Designating it by F , there results,

$$F = \frac{P/a}{e/l} \quad \text{or} \quad F = \frac{S_s}{\epsilon} \tag{15}$$

where ϵ is the unit-detrusion e/l . These formulas are the same as those of Art. 9, but the above remarks show that the meanings of the letters e and ϵ are somewhat different in the two cases.

The following are approximate average values of the shearing modulus of elasticity as ascertained by experiments and computations which are explained in Arts. 93 and 181:

Material	Shearing Modulus of Elasticity
Timber, across grain	400 000 pounds per square inch
Cast Iron	6 000 000 pounds per square inch
Wrought Iron	10 000 000 pounds per square inch
Steel	12 000 000 pounds per square inch

For brick, concrete, and stone there is but little known regarding the shearing modulus of elasticity.

By the help of the above formulas, computations regarding elastic deformations in shear may be made in the same manner as those for tension and compression in Art. 10. For example, take a short wooden block 6 inches long and 3×4 inches in section subject to a shear of 24 000 pounds. The shearing unit-stress is $24\ 000/12 = 2\ 000$ pounds per square inch, which is probably a little less than the elastic limit for shear (Art. 2) and hence the formula applies. The unit-detrusion then is $\epsilon = 2\ 000/400\ 000 = 0.005$, and the total detrusion or lateral movement of one end of the block with respect to the other is $e = 0.005 \times 6 = 0.03$ inches.

The work done in deforming the prism of Fig. 15 is $\frac{1}{2}Pe$, when the load is applied by increments so that the shearing force increases from 0 up to P , and when the elastic limit is not exceeded by the unit-stress S . This work of elastic detrusion may be written $\frac{1}{2}S\epsilon \cdot al$, which is identical with the expression deduced for tension or compression in the last article.

The above formulas cannot be used when the unit-stress S exceeds the elastic limit for shear, which is usually about 75 or 80 percent of that for tension. They cannot be used when the length l is large compared with the lateral dimensions of the body, for then a bending occurs so that BC' is not a straight line and in this case e/l cannot be a constant for variable values of e and l . They are of principal value in discussing the twisting of shafts (Art. 93).

Prob. 15. A cast-iron beam, 2 inches square, has two loads of 8 000 pounds near the supports as shown in Fig. 6*b*. The beam being originally horizontal, compute the inclination between a support and a load after the loads are placed upon it.

ART. 16. HISTORICAL NOTES

From the earliest times a few fundamental facts regarding the strength of materials were undoubtedly known by experience, such, for instance, that stone was stronger than wood. No quantitative results appear, however, to have been ascertained and recorded until about the middle of the eighteenth century.

The first investigation in the mechanics of materials seems to be that made by Galileo in 1638 on the flexure of a beam, in which he regarded all the fibers as inextensible. It was not until more than a century afterwards that tests of the strength of bars were made, and these related almost entirely to its ultimate strength, the elastic limit being unknown and unrecognized.

In 1678 Hooke announced the theory of "springy bodies" which he expressed by "ut tensio sic vis", namely, elongation is proportional to force; three years previously he had performed an experiment before the king of England which illustrated this theory, and in 1676 he had announced it concealed in the anagram "ceiinossttuv." Newton in 1704 conjectured that the return of the body to its original form, after the removal of the force, was caused by the mutual attraction of its particles.

Early in the nineteenth century appeared the Lectures on Natural Philosophy by Young in which the modulus of elasticity is for the first time introduced, but no note is made that it only be deduced or applied when the elastic limit of the material is not exceeded. The first observations regarding this limit were made a few years later by the experimenters Barlow and Tredgold, who noted the permanent set in their tests of cast-iron bars.

After 1830 metallic bridges came into use through the necessities of railroad construction, and numerous experiments on cast iron and wrought iron were made in England, France, and Germany. In 1849 a British commission conducted tests of these metals more exhaustive than any made before, and for the first time established definite conclusions regarding the use of factors of safety, one of which was that the factor for cast iron should be twice as great for sudden loads as for steady ones. After this date specifications for important structures contained requirements regarding working stresses, laboratories for testing materials were established, improved methods and machines were devised, and the theory of the subject was greatly extended.

The first testing machines in the United States of America were those built between 1850 and 1860 for experiments on gun-metal. At the present time every large manufacturer of iron

and steel has a testing laboratory where specimens are constantly broken in order to gain knowledge whereby the quality of the product may be improved or to be certain that it meets the specifications of the buyers. All engineering colleges have testing laboratories for the instruction of students and for scientific research. The literature of the subject is enormous, and societies, both national and international, have been formed to improve the methods of testing and to render more perfect the knowledge of the properties of materials under stress. All this work has been done for the purpose of advancing stability and economy in engineering construction, and the two principles stated in Art. 7 have been its fundamental guides.

The average values of the elastic limits, modulus of elasticity, ultimate strengths and ultimate elongations given in the preceding pages and in Tables 2, 3, 4, at the end of this volume, have been derived from the records of tests made since 1850. It must not be forgotten that these values are subject to much variation, depending upon the quality of the material, its method of manufacture, and to some extent upon the suddenness with which the forces are applied. In practice all these points must be carefully considered and precise knowledge be obtained, as far as possible, regarding the actual material in hand. The next chapter gives more detailed information regarding the elasticity and strength of different qualities of the materials mentioned in the preceding pages and also of other materials used in engineering and the arts, while Arts. 168–170 give discussions regarding methods of testing.

Prob. 16*a*. Consult Vol. I of Todhunter's History of the Elasticity and Strength of Materials and ascertain the exact words in which Young defined the Modulus of Elasticity.

Prob. 16*b*. "Tests of Metals. . . at the Watertown Arsenal" is the title of a publication issued yearly by the Ordnance Department of the U. S. Government. Consult one of these volumes and ascertain the elastic limit and ultimate strength of rifle-barrel steel.

CHAPTER III

MATERIALS OF ENGINEERING

ART. 17. AVERAGE WEIGHTS

THE following are average values of the weights per unit of volume and of the specific gravities of the principal materials used in engineering constructions. These weights should be carefully memorized by the student as a basis for more precise

Material	Weight	Specific Gravity
Brick	125 pounds per cubic foot	2.0
Stone	160 pounds per cubic foot	2.6
Timber	40 pounds per cubic foot	0.6
Cast Iron	450 pounds per cubic foot	7.2
Wrought Iron	480 pounds per cubic foot	7.7
Steel	490 pounds per cubic foot	7.8

knowledge, but it must be noted that they are subject to considerable variation with the quality of the material. For instance, brick may weigh as low as 100 or as high as 150 pounds per cubic foot, according as it is soft or pressed. Unless otherwise stated, the above average values will be used in all the following examples and problems of this volume. Table 1, at the end of this volume, gives these constants in metric measures, and it will be noted that the unit-weights in this convenient system are multiples of the specific gravities.

The following approximate simple rules, stated in 1885 in the first edition of this book, are in general use among engineers for computing the weights of bars and beams which are of uniform cross section:

A wrought-iron bar one square inch in section and one yard long weighs ten pounds.

Steel is about two percent heavier than wrought iron.

Cast iron is about six percent lighter than wrought iron.

Stone is about one-third the weight of wrought iron.

Brick is about one-fourth the weight of wrought iron.

Timber is about one-twelfth the weight of wrought iron.

For example, consider a bar of wrought iron $1\frac{1}{2} \times 3$ inches and 12 feet long; its section area is 4.5 square inches, hence its weight is $45 \times 4 = 180$ pounds. A steel bar of the same dimensions weighs $180 + 0.02 \times 180 =$ about 184 pounds, a cast-iron bar weighs $180 - 0.06 \times 180 =$ about 169 pounds, and a timber bar weighs $180/12 =$ about 15 pounds.

By reversing the above rules, the section areas of bars are readily computed from their weights per yard. Thus, if a stick of timber 15 feet long weighs 120 pounds, its weight per yard is 24 pounds, and its section area is $12 \times 2.4 = 28.8$ square inches approximately. Again, if a steel bar weighs 26.5 pounds per linear foot, its section area is $3 \times 26.5(1 - 0.02)/10 = 7.79$ square inches.

It may be noted that, as a rough general rule, the strengths of heavy bodies are greater than those of lighter bodies of the same size. Thus, steel is the heaviest material of construction and it is the strongest. Strictly speaking this rough rule applies only to materials of a similar nature, and is only valid for comparing metals with metals, stony materials with stony materials, and timber with timber. Thus, the heaviest kinds of timber are the strongest, but many kinds of timber are stronger than stone or brick.

Prob. 17. What is the weight of a stone block 12×18 inches in section area and 5 feet long? If a cast-iron pipe 12 feet long weighs 985 pounds, what is its section area?

ART. 18. PLASTICITY AND BRITTLENESS

The property of elasticity which has been explained in the preceding chapters is possessed by different materials in different degrees. A perfectly elastic material is one which springs back to its original shape on the removal of the applied force, this force having any magnitude less than that required to cause rupture. No material with perfect elasticity is known; india-rubber is the nearest approach to it, but even this fails to return

to its original form when it has been under stress for some time. Wrought iron and steel are only elastic when the applied force is less than about fifty or sixty percent of that required to cause rupture, that is, when the unit-stress does not exceed the elastic limit (Art. 2). Cast iron, stone, and timber have poorly defined elastic limits, as the stress diagrams in Fig. 11*a* show, and for many qualities small stresses produce permanent sets, so that their degree of elasticity is less than that of wrought iron and steel.

A material which has no elasticity, so that the smallest forces cause permanent deformations, is called 'plastic'. Lead is an example of a plastic material, for a flow of the metal occurs under slight forces and there is no return to the original form. Lead has no elastic limit, and it has no ultimate compressive strength in the ordinary sense, for the material flows as the compression is applied, so that the original prism constantly decreases in height and increases in section until it becomes a thin sheet.

Wrought iron and structural steel are materials which are more or less plastic under stresses exceeding their elastic limits. In tension bars of these materials recover a small part of their original length on the removal of the load, and hence they have some elasticity, but the elongation which remains as permanent set represents their plasticity. Under compression the elasticity is less and the plasticity is more marked, especially for structural steel, so that this variety of steel cannot be said to have a compressive strength in the ordinary sense, its behavior resembling that of lead.

A material which cannot change its shape without rupture is said to be 'brittle'. There is no body perfectly brittle, but glass approaches it most nearly, since small changes of shape are followed by rupture. Cast iron is the most brittle of the common materials of construction, since its percentage of elongation under tension is the least (Art. 4). Brick and stone are brittle materials compared with timber or steel. In general the greater the deformation which a body will withstand before rupture the less is its degree of brittleness. Plasticity is the reverse of brittleness.

When bars are subject to tensile stress, those of brittle material rupture with but slight change in the area of the cross-section, while those of plastic material rupture with a considerable reduction of area accompanied by a taper on each side of the place of rupture. The greater the reduction of area (Art. 12) the less is the degree of brittleness of the material. When prisms are subject to compressive stress, those of brittle material rupture by an oblique splitting or shearing, as seen in Fig. 169*b*, which shows a cement cube and an oak block. The greater the brittleness the greater is the inclination of these shearing planes to the horizontal. Fig. 18*a* indicates these lines of rupture for anthracite coal, Fig. 18*b* for paving brick, Fig. 18*c* for cement or concrete, and Fig. 18*d* for timber; in all these cases the change in section area is very slight. For a plastic material, however, the increase in section area is large, and no shearing planes arise; Fig. 18*e* illustrates this case.

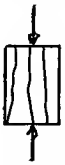
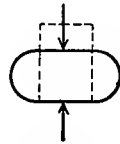
Fig. 18*a*Fig. 18*b*Fig. 18*c*Fig. 18*d*Fig. 18*e*

The materials of engineering all possess a certain degree of elasticity and certain degrees of plasticity and brittleness. Hard steel is elastic within the elastic limit; beyond that limit it is in part elastic, in part plastic, and in part brittle, while soft steel has but little brittleness. Cast iron has defective elasticity, no plasticity, and considerable brittleness. Timber resembles cast iron in regard to elasticity, but some varieties are more plastic than brittle.

The word elasticity is used in the mechanics of materials with a slightly different meaning from that of popular language. In common parlance a body is called elastic when it can undergo great deformations and then recover its original form, the greater the stretch under a given force the greater being the elasticity. In the mechanics of materials the amount of the deformation is not considered, but merely the ability to return to the original

shape. In common language steel would not be spoken of as an elastic material, but according to the definition here given its degree of elasticity is a high one if the unit-stress does not exceed the elastic limit. The constant called the modulus of elasticity (Art. 9) is really an index of stiffness, that is, the higher the modulus the less will be the amount of deformation under a given unit-stress.

Prob. 18*a*. What is the weight in kilograms of a pig of lead, 0.75 meters long and 215 square centimeters in section area, its specific gravity being 11.38?

Prob. 18*b*. A concrete cube weighed $181\frac{1}{2}$ ounces in air and $107\frac{1}{2}$ ounces in water. Compute its specific gravity, and its weight in pounds per cubic foot. What was the size of the concrete cube?

ART. 19. TIMBER

Good timber is of uniform color and texture, free from knots, sapwood, wind-shakes, worm-holes, or decay; it should also be well seasoned, which is best done by exposing it for two or three years to the weather to dry out the sap. The heaviest timber is usually the strongest; also the darker the color and the closer the annular rings the stronger and better it is, other things being equal. The strength of timber is always greatest in direction of the grain, the sidewise resistance to tension or compression being scarcely one fourth of the longitudinal.

The following table gives average values of the ultimate

Kind	Weight Pounds per Cubic Foot	Pounds per Square Inch		
		Tensile Strength	Computed Flexure Strength	Compress- ive Strength
Hemlock	25	8 000	6 000	5 000
White Pine	27	8 000	6 000	5 500
Chestnut	40	12 000	7 000	5 000
Red Oak	42	9 000	7 000	6 000
Yellow Pine	45	15 000	11 000	9 000
White Oak	48	12 000	10 000	8 000

strength of a few of the common kinds of timber as determined from tests of small specimens which were carefully selected and dried. Large pieces of timber, such as are actually used in engineering structures, have an ultimate strength of from fifty to eighty percent of these values. Moreover the figures are liable to a range of 25 percent on account of variations in quality and condition arising from place of growth, time when cut, and method and duration of seasoning. The amount of moisture in timber also influences its strength; timber which has absorbed water in amount equal to one-half of its dry weight has a strength only about one-half that of dried timber. To cover all these variations the factor of safety of 10 (Art. 7) is not too high.

The column headed 'computed flexure strength' in the above table gives the unit-stress computed from the rupture of beams, using the flexure formula (Art. 41). This quantity is always intermediate between the tensile and compressive strengths, but it is not a physical constant, as will be explained in Art. 52; it is sometimes called the 'modulus of rupture'.

The shearing strength of timber is still more variable than the tensile or compressive resistance. White pine across the grain may be put at 2 500 pounds per square inch, and along the grain at 500. Chestnut has 1 500 and 600, yellow pine and oak about 4 000 and 600 pounds per square inch in these directions respectively.

The elastic limit of timber is poorly defined. In precise tests on good specimens it is sometimes observed at about one-half the ultimate strength, but under ordinary conditions it is safer to put it at one-third. The modulus of elasticity ranges from 1 000 000 to 2 000 000 pounds per square inch, 1 500 000 being a good mean value to use in general computations. The ultimate elongation is small, usually being between 1 and 2 percent. Fig. 169*b* shows the common way in which a short timber prism ruptures under compression.

The tests published in the Census Report on the Forest Trees of North America (1884) are very comprehensive, as they include 412 species of timber. Of these 16 species have a specific gravity

greater than 1.0 and 28 species less than 0.4. Even in the same species a great variation in weight was often found; for instance white oak ranged from 42 pounds to 54 pounds per cubic foot. The heaviest wood weighed 81 pounds per cubic foot and had a compressive strength of 12 000 pounds per square inch; the lightest wood weighed 16 pounds per cubic foot and had a compressive strength of 200 pounds per square inch.

Prob. 19a. Which is the safer under compression, hemlock under 600 or white oak under 800 pounds per square inch?

Prob. 19b. Square sticks of white pine and yellow pine are subject to a steady load which brings a tension of 10 000 pounds upon each. Compute their size for the proper factor of safety.

ART. 20. BRICK

Brick is made of clay which is prepared by cleaning it carefully from pebbles and sand, mixing it with about one-half its volume of water and tempering it by hand stirring or in a pug-mill. It is then molded into rectangular form either in wooden boxes by hand or in metal forms by machines, and the green bricks are placed under open sheds to dry. These are piled in a kiln and heated for nearly two weeks or until those nearest to the fuel assume a partially vitrified appearance.

Three qualities of brick are taken from the kiln: 'arch brick' are those from around the arches where the fuel is burned—these are hard and often brittle; 'body brick', from the interior of the kiln, are of the best quality; 'soft brick', from the exterior of the pile, are weak and only suitable for filling. Paving brick are burned in special kilns, often by natural gas or by oil, the rate of heating being such as to insure toughness and hardness and also a uniform product throughout the entire kiln.

A common size is $2\frac{1}{4} \times 4 \times 8\frac{1}{4}$ inches, and the average weight $4\frac{1}{2}$ pounds. A pressed brick, however, may weigh nearly $5\frac{1}{2}$ pounds. Good bricks should be of regular shape, have parallel and plane faces, with sharp angles and edges. They should be of uniform texture and when struck a quick blow should give a

sharp metallic ring. The heavier the brick, other things being equal, the stronger and better it is.

Poor brick will absorb when dry from 20 to 30 per cent of its weight of water, ordinary qualities absorb from 10 to 20 per cent, while hard paving brick should not absorb more than 2 or 3 per cent. An absorption test is valuable in measuring the capacity of brick to resist the disintegrating action of frost, and as a rough general rule the greater the amount of water absorbed the less is the strength and durability.

The compressive strength of brick is variable; while a mean value may be 2 500 pounds per square inch, soft brick will scarcely stand 500, pressed brick may run to 10 000, and the best qualities of paving brick have given 15 000 pounds per square inch, or even more. Compressive tests are generally made on half-bricks, the compression being applied normal to the smallest side, that is parallel to the width of the brick; the failure usually occurs by an oblique shearing as indicated in Fig. 18*b*.

Brick is rarely used in tension and but little is known of its behavior under such stress; the ultimate tensile strength may perhaps range from 50 to 500 pounds per square inch. The ultimate shearing strength of good building brick is about 500 pounds per square inch, and higher for the paving qualities.

Brick may be classed as a brittle material, the stress diagram resembling that of cast iron. Its elastic limit is not well defined, but its deformation within that limit is greater than that of cast iron, the modulus of elasticity E generally ranging from 1 000 000 to 3 000 000 pounds per square inch. Bricks saturated with water have about the same strength and elastic properties as dry bricks.

Brick masonry has a much smaller strength than that of the individual bricks, on account of the lack of perfect union at the joints and also of the generally lower strength of the mortar. The strength of a brick pier, indicated by the loosening and cracking of the joints, is about one-fourth of the compressive strength of an individual brick.

Prob. 20a. Using the mean values of Arts. 5 and 17 and the statement of the last paragraph, compute the height of a brick tower which will crush at the base under its own weight.

ART. 21. STONE

Sandstone, as its name implies, is sand, usually quartzite, which has been consolidated under heat and pressure. It varies much in color, strength, and durability, but many varieties form most valuable building material. In general it is easy to cut and dress, but the variety known as Potsdam sandstone is very hard in some localities.

Limestone is formed by consolidated marine shells, and is of diverse quality. Marble is limestone which has been reworked in the laboratory of nature so as to expel the impurities, and leave a nearly pure carbonate of lime; it takes a high polish, is easily worked, and makes one of the most beautiful building stones.

Granite is a rock which was formerly supposed to be of aqueous origin metamorphosed under heat and pressure, but it is now generally thought to be of igneous origin; its composition is quartz, feldspar, and mica, but in the variety called syenite the mica is replaced by hornblende. It is fairly easy to work, is usually strong and durable, and some varieties will take a high polish.

Trap, or basalt, is an igneous rock without cleavage. It is hard and tough, and less suitable for building constructions than other rocks, since large blocks cannot be readily obtained and cut to size. It has, however, a high strength and is remarkable for durability.

The average weights and ultimate strengths of these four classes are given in the following table. These figures refer to small specimens such as can be broken in a testing machine, and it is known that the strength of large blocks per square inch is materially less. The rupture of a cube or prism of stone under compression often occurs by splitting, or rather shearing,

in planes making an angle of about 25 degrees with the direction of the pressure (see Fig. 18*b*).

Kind	Pounds per Cubic Foot	Pounds per Square Inch	
	Weight	Compressive Strength	Shearing Strength
Sandstone	150	5 000	1 200
Limestone	160	7 000	1 500
Granite	165	12 000	2 000
Trap	175	15 000	2 500

The modulus of elasticity of stone has been found to range from 5 000 000 to 10 000 000 pounds per square inch. The elastic limit is difficult to observe, if indeed any exists, but the first sign of cracking is sometimes regarded as marking this limit. Little is known regarding the tensile strength, except that it is much less than the compressive strength, and stone is rarely subjected to tensile stresses.

The quality of a building stone cannot be safely inferred from tests of strength, as its durability depends largely upon its capacity to resist the action of the weather. Hence corrosion and freezing tests, impact tests, and observations of the behavior of stone under conditions of actual use are more important than the determination of crushing strength in a compression machine. The strength of a stone pier is only about one-fourth of that of the stone itself, on account of the weakness of the mortar joints.

Slate is an argillaceous stone consolidated under very heavy pressure which has produced a marked cleavage. It is split into plates $\frac{1}{4}$ inch in thickness for use as roofing slate, and in larger blocks is used for pavements and steps. Its weight per cubic foot is about 175 pounds, its compressive strength about 10 000 pounds per square inch, and its computed flexural strength about 7 000 pounds per square inch. Slate is liable to corrode under the action of the atmosphere, and its marked cleavage and grain render its strength variable in different directions; hence it is unsuitable for a building stone.

Prob. 21. How many cubic yards of masonry are contained in a pier 12×30 feet at the base, 8×24 feet at the top, and $16\frac{1}{2}$ feet high? What is its cost at \$6.37 per cubic yard?

ART. 22. MORTAR AND CONCRETE

Common mortar is composed of one part of lime to five parts of sand by measure. When six months old its tensile strength is from 15 to 30 and its compressive strength from 150 to 300 pounds per square inch. Its strength slowly increases with age, and a smaller proportion of sand produces mortar stronger than the above values.

Hydraulic mortar is composed of hydraulic cement and sand in varying proportions. The less the proportion of sand the greater is its strength. If S be the strength of neat cement, that is, of cement with no sand, the strength of mortar having p parts of sand to one part of cement is about $S/(1+p)$ as a rough approximation. A common proportion is 3 parts of sand to 1 of cement, the strength of this being about one-fourth that of the cement itself. The strength of hydraulic mortar also increases with its age.

There are two classes of hydraulic cements, the natural cements and the Portland cements. The former are of lighter color, lower weight, and lesser strength than the latter, but they are quicker in setting and cheaper in price. The following table gives average ultimate tensile strengths in pounds per

Proportion of Sand	NATURAL			PORTLAND		
	One Week	One Month	One Year	One Week	One Month	One Year
0	120	200	350	300	400	500
1 to 1	70	125	250	125	200	350
2 to 1	30	60	180	100	150	300
3 to 1	20	30	130	80	125	250
4 to 1	10	20	100	50	70	150

square inch of mortars of both classes of different ages and different proportions of sand. These figures are obtained from tests

of briquettes carefully made in molds, and are higher than hydraulic mortar made under usual circumstances will give. The briquette is removed from the mold when set, allowed to remain in air for one day, and then put under water for the remainder of the time.

Since cements and mortars are used only in compression, the tensile tests may seem an inappropriate one. Compressive tests, however, are more expensive than tensile ones. It may be taken as a general rule that the compressive strength of a material increases with the tensile strength, and it is certain that the universal adoption of the tensile tests has done much to greatly improve the quality of hydraulic cements.

For neat cement a one-day tensile test is frequently employed, the briquette being put under water as soon as it has set. For natural cement a briquette one square inch in section should give a tensile strength of 75 pounds, while one of Portland cement should give 125 pounds. To secure these results, however, the material should be thoroughly rammed into the molds, no more water being used than necessary, and the quality of the cement must be good.

The compressive strength of hydraulic cements and mortars is from six to ten times the tensile strength. Fig. 169*b* shows the manner in which a cube of cement fails under compression. Neat Portland cement when one month old has a compressive strength of about 3 000, and when one year old about 5 000 pounds per square inch. Natural cement mortar when three or four years old has a compressive strength of about 2 500 pounds per square inch. The adhesion of cement to stone or brick is somewhat less than the tensile strength. The shearing strength of cement or mortar is much less than the compressive strength, usually only about one-fourth or one-third.

The strength of cement and mortar is influenced by many causes: the quality of the stone or materials from which the cement is made, the method of manufacture, the age of the cement, the kind of sand, the method of mixing, and even the amount of water used. Mortar joints are, as a rule, weaker

than the bricks or stones which they unite, and the failure of a masonry wall usually begins by cracking along these joints.

Concrete is an artificial stone which is made by mixing hydraulic mortar and broken stones. The best proportions are such that the grains of sand fill all the voids between the stones, while the cement fills all the voids between the sand grains, as also those between the sand and the stones. Common proportions for a first-class concrete are 1 cement, 2 sand, and 4 broken stone, by measure. Concrete is mainly used for floors, walls, foundations, and monolithic structures, but sometimes blocks are made which are laid together like stone masonry. Its use has greatly increased since 1900 and many concrete piers and bridges have been built. Reinforced concrete is concrete in which steel rods are imbedded in order to increase its tensile resistance (Art. 113).

The average weight of concrete is about 150 pounds per cubic foot. Its strength increases with age, like that of hydraulic mortar. For concrete made with the proportions 1 cement, 2 sand, 4 broken stone, when six months old, the average tensile strength is 400 pounds per square inch, compressive strength 3 500 pounds per square inch, and modulus of elasticity 3 000 000 pounds per square inch. For concrete with the proportions 1 cement, 3 sand, 6 broken stone, when six months old, the average tensile strength is 300 pounds per square inch, compressive strength 2 500 pounds per square inch, and modulus of elasticity 2 000 000 pounds per square inch. These figures refer to concrete in which Portland cement is used, the strength being about twenty percent less for natural cement concrete. When one year old the ultimate strengths are a little greater than the above figures. The elastic limit of concrete is not well defined, and if one is to be stated, that in compression may be roughly put at about one-third or one-fourth of the compressive strength. The allowable unit-stress usually ranges from one-sixth to one-eighth of the ultimate strength.

Prob. 22. Let the pier of Problem 21 be concrete and carry a load of 460 000 pounds. Compute its weight and the compressive unit-stress on its base.

ART. 23. CAST IRON

Cast iron is a modern product, having been first made in England about the beginning of the fifteenth century. Ores of iron are melted in a blast furnace, producing pig iron. The pig iron is remelted in a cupola furnace and poured into molds, thus forming castings. Beams, columns, pipes, braces, and blocks of every shape required in engineering structures are thus produced.

Pig iron is divided into two classes, Foundry pig and Forge pig, the former being used for castings and the latter for making wrought iron and steel. Foundry pig has a dark-gray fracture, with large crystals and a metallic luster; forge pig has a light-gray or silver-white fracture, with small crystals. Foundry pig has a specific gravity of from 7.1 to 7.2, and it contains from 6 to 4 percent of carbon; forge pig has a specific gravity of from 7.1 to 7.4, and it contains from 4 to 2 percent of carbon. The higher the percentage of carbon the less is the specific gravity, and the easier it is to melt the pig. Besides the carbon there are present from 1 to 5 percent of other impurities, such as silicon, manganese, and phosphorus.

The properties and strength of castings depend upon the quality of the ores and the method of their manufacture in both the blast and the cupola furnace. Cold-blast pig produces stronger iron than the hot-blast, but it is more expensive. Long-continued fusion improves the quality of the product, as also do repeated meltings. The darkest grades of foundry pig make the smoothest castings, but they are apt to be brittle; the light-gray grades make tough castings, but they are apt to contain blow-holes or imperfections.

The percentage of carbon in cast iron is a controlling fact or which governs its strength, particularly that percentage which is chemically combined with the iron. For example, the following are the results of tests made by Wade about 1860 of three classes of cast iron then used for guns, the tensile strength being in pounds per square inch:

No.	Specific Gravity	Percentage of Carbon Graphite	Percentage of Carbon Combined	Ultimate Tensile Strength
1	7.204	2.06	1.78	28 800
2	7.154	2.30	1.46	24 800
3	7.087	2.83	0.82	20 100

Here it is seen that the total carbon is about the same in the three kinds, but the greater the percentage of combined carbon the higher is the specific gravity and ultimate strength.

As average values for the ultimate strength of cast iron, 20 000 and 90 000 pounds per square inch in tension and compression respectively are good figures. In any particular case, however, a variation of from 10 to 20 per cent from these values may be expected, owing to the variations in quality. For first-class gun iron Wade found a tensile strength of over 30 000 and a compressive strength of over 150 000 pounds per square inch. On the other hand medium-quality castings often have a tensile strength less than 16 000 pounds per square inch.

In tensile tests the elongations within the elastic limit are not exactly proportional to the applied loads, so that the elastic limit is poorly defined, and the modulus of elasticity may range from 12 000 000 to 18 000 000 pounds per square inch. The elastic limit in tension may be roughly stated at 6 000 pounds per square inch, but that for compression is much higher, probably about 20 000 pounds per square inch.

The flexural test is a good one for comparing the strength of different bars of cast iron. A bar one inch square and 14 inches long is laid on two supports 12 inches apart and a load gradually applied to the middle until rupture occurs; the load required will be about 2 000 pounds for average grades. For a bar 2×1 inches in section area, laid flatwise on two supports 24 inches apart, the load at the middle which causes rupture will also be about 2 000 pounds.

The high compressive strength and the cheapness of cast iron render it a valuable material for many purposes, but its brittleness, low tensile strength, and lack of ductility forbid its use in structures subject to variations of load or to shocks.

Its ultimate elongation being scarcely one percent, the work required to cause rupture is small compared to that for wrought iron and steel. Cast iron is no longer used in bridges, and for important buildings it has been but little employed since 1895.

Malleable cast iron is made by surrounding castings with decarbonizing material and heating them in annealing ovens. The carbon is thus partly removed to a certain depth below the surface of the castings, and this renders the material much stronger in tension, while its elongation is increased. The process is only applicable to small castings, but for these the tensile strength may be doubled and the ultimate elongation be made eight or ten times as great as that of common cast iron, thus rendering it more efficient in resisting shocks.

Prob. 23. Compute the weight of a cast-iron water pipe 12 feet long and 20 inches in internal diameter, the average thickness of the metal being $1\frac{1}{4}$ inches.

ART. 24. WROUGHT IRON

The ancient peoples of Europe and Asia were acquainted with wrought iron and steel to a limited extent. The name of an ironmaster is mentioned in Genesis iv 22, and in one of the oldest pyramids of Egypt a piece of iron has been found. It was produced, undoubtedly, by the action of a hot fire on very pure ore. The ancient Britons built bloomeries on the tops of high hills, a tunnel opening toward the north furnishing a draft for the fire which caused the carbon and other-impurities to be expelled from the ore, leaving behind nearly pure metallic iron.

Modern methods of manufacturing wrought iron are mainly by the use of forge pig (Art. 23) in the puddling process. Here the forge pig is subjected to the oxidizing flame of a blast in a reverberatory furnace, where it is formed into pasty balls by the puddler. A ball taken from the furnace is run through a squeezer to expel the cinder and then rolled into a muck bar. The muck bars are cut, laid in piles, heated, and rolled, forming what is called merchant bar. If this is cut, piled, and rolled again a

better product called best iron is produced. A third rolling gives 'best-best' iron, a superior quality, but high in price.

The product of the rolling mill is bar iron, plate iron, shape iron, beams, and rails. Bar iron is round, square, and rectangular in section; plate iron is from $\frac{1}{4}$ to 1 inch thick, and of varying widths and lengths; shape iron includes angles, tees, channels, and other forms used in structural work; beams are I-shaped, and of the deck or bulb form (Art. 44).

Wrought iron is metallic iron containing less than 0.25 percent of carbon, and which has been manufactured without casting from the fluid state. Its elastic limit is well defined at about 24 000 pounds per square inch and the yield point at about 26 000 pounds per square inch; within this limit it is stiffer than cast iron, the modulus of elasticity being about 25 000 000 pounds per square inch. Its average ultimate tensile strength is about 50 000 pounds per square inch, and its ultimate elongation is from 25 to 30 percent. In comparison it is plastic beyond the elastic limit, so that the compressive strength given in Art. 5 has but little meaning. It is malleable, can be forged and welded, and has a high capacity to withstand the action of shocks; it cannot, however, be tempered so as to form cutting tools.

The cold-bend test for wrought iron is an important one for judging of general quality. A bar, perhaps $\frac{3}{4} \times \frac{3}{4}$ inches and 15 inches long, is bent when cold either by pressure or by blows of a hammer. Bridge iron should bend, without cracking, through an angle of 90 degrees to a curve whose radius is twice the thickness of the bar. Rivet iron should bend, without showing signs of fracture, through 180 degrees until the sides of the bar are in contact. Wrought iron that breaks under this test is lacking in both strength and ductility.

The process of manufacture, as well as the quality of the pig iron, influences the strength of wrought iron. The higher the percentage of carbon the greater is the strength. Best iron is 10 percent stronger than ordinary merchant iron owing to the influence of the second rolling. Cold rolling causes a marked increase in elastic limit and ultimate strength, but a decrease

in ductility or ultimate elongation. Annealing lowers the ultimate strength, but increases the elongation. Iron wire, owing to the process of drawing, has a high tensile strength, sometimes greater than 100 000 pounds per square inch.

Good wrought iron when broken by tension shows a fibrous structure. If, however, it be subject to shocks or to repeated stresses which exceed the elastic limit, the molecular structure becomes changed so that the fracture is more or less crystalline. The effect of a stress exceeding the elastic limit is to cause a permanent set, but the elastic limit will be found to be higher than before. This is decidedly injurious to the material on account of the accompanying change in structure and because its capacity to resist work is less than before, as Fig. 11*b* shows; hence it is a fundamental principle that the working unit-stresses should not exceed the elastic limit. For proper security the allowable unit-stress should seldom be greater than one-half the elastic limit.

Prior to 1890 wrought iron was generally employed for structural purposes, but medium steel, on account of its smaller cost and greater strength, then began to come into use, and the change was so rapid that since 1900 it has almost entirely displaced wrought iron in bridge and building construction. Wrought iron is, however, still employed for chains, for stay bolts, and for many other purposes where great ductility and toughness are demanded. Owing to the fact that it was used so extensively in the nineteenth century and that its properties were then so well ascertained by numerous tests, it will long remain in engineering literature as a standard with which other materials may be advantageously compared. Since 1900 much pig iron has been made in America by casting in open molds instead of in a sand bed, and wrought iron made from such pig appears to be lower in strength than that of the nineteenth century.

Prob. 24. Compute the section area of a wrought-iron bar 30 feet long which weighs 418 pounds. If this bar is hung vertically at its upper end, compute the unit-stress at that end and at the middle. What load, hung at the lower end, will stress it to the elastic limit?

ART. 25. STEEL

Steel was originally produced directly from pure iron ore by the action of a hot fire, which did not remove the carbon to a sufficient extent to form wrought iron. The modern processes, however, involve the fusion of the ore, and the definition of the United States law is that "steel is iron produced by fusion by any process, and which is malleable." Chemically, steel is a compound of iron and carbon generally intermediate in composition between cast and wrought iron, but having a higher specific gravity than either. The following comparison points out the distinctive differences between the three kinds of iron:

	Percent of Carbon	Specific Gravity	Properties
Cast iron,	5 to 2	7.2	Not malleable, not temperable
Steel,	1.50 to 0.10	7.8	Malleable and temperable
Wrought iron,	0.30 to 0.05	7.7	Malleable, not temperable

It should be observed that the percentage of carbon alone is not sufficient to distinguish steel from wrought iron; also, that the mean values of specific gravity stated are in each case subject to considerable variation; further, only the hard steels are temperable, the softer grades resembling wrought iron.

The three principal methods of manufacture are the crucible process, the open-hearth process, and the Bessemer process. In the crucible process impure wrought iron or blister steel, with carbon and a flux, are fused in a sealed vessel to which air cannot obtain access; the best tool steels are thus made. In the open-hearth process pig iron is melted, wrought-iron scrap being added until the proper degree of carbonization is secured. In the Bessemer process pig iron is completely decarbonized in a converter by an air blast and then recarbonized to the proper degree by the addition of spiegeleisen. The metal from the open-hearth furnace or from the Bessemer converter is cast into ingots which are rolled in mills to the required forms. The open-hearth process produces steel for machines, shafts, axles, springs, armor plates, and for structural purposes; the Bessemer process mainly produces steel for railroad rails.

'Acid steel' is that made in a furnace having a silicious lining, while 'basic steel' is that made in a furnace with dolomitic linings. These terms have no reference to quality and refer mainly to process of manufacture, but the basic process enables ores high in phosphorus to be used, the phosphorus being removed by the addition of lime. Acid steel is slightly stronger than basic steel, owing partly to the higher percentage of phosphorus and partly to the effect of the lime in forming slag in the basic steel. Since 1900 more than three-fourths of the open-hearth steel produced in the United States has been basic; the Bessemer product on the other hand being entirely acid.

The physical properties of steel depend both upon method of manufacture and chemical composition, the carbon having the controlling influence upon strength. Phosphorus increases strength, but it promotes brittleness; manganese increases strength in a less degree, and it promotes malleability; sulphur causes red-shortness, or a tendency of the steel to crumble while being rolled; and silicon increases hardness.

Many formulas have been deduced to exhibit the relation between the tensile strength and the chemical composition, but none of these applies to all classes of steel. The rough rules,

$$S_t = 45\,000 + 108\,000C \qquad S_t = 45\,000 + 90\,000C$$

give an approximate idea of the influence of carbon in acid and basic unannealed open-hearth steel respectively, C being the percentage of carbon and S_t the tensile strength in pounds per square inch. Thus, acid steel with 0.40 percent of carbon has a tensile strength of about 88 000 pounds per square inch, while basic steel has about 81 000 pounds per square inch. When the percentages of phosphorus and manganese are also known, the following formulas which have been deduced from the exhaustive discussion given by Campbell in 1905 may be used to give more reliable results, namely,

$$S_t = 40\,000 + 68\,000C + 100\,000P + 80\,000CM$$

$$S_t = 38\,800 + 65\,000C + 100\,000P + 9\,000M + 40\,000CM$$

the first being for acid and the second for basic open-hearth

steel. Here C is the percentage of carbon, P that of phosphorus, M that of manganese, and S_t the tensile strength in pounds per square inch. For example, acid steel having 0.344 percent of carbon, 0.045 percent of phosphorus, and 0.70 per cent of manganese has a tensile strength of 87 200 pounds per square inch; basic steel having 0.344 percent of carbon, 0.020 percent of phosphorus, and 0.35 percent of manganese has a tensile strength of 71 100 pounds per square inch. These formulas do not apply to steel with a percentage of carbon higher than 0.75.

Carbon is the controlling element in regard to strength, and the same is the case with respect to ultimate elongation. The higher the percentage of carbon, within a reasonable limit, the greater is the strength and the less the ultimate elongation. The product of strength and elongation is approximately constant, and hence the ultimate elongation is approximately inversely proportional to the tensile strength. A rule frequently given is that the percentage of elongation equals $1\ 500\ 000/S_t$; thus, for a tensile strength of 80 000 pounds per square inch the ultimate elongation is about 19 percent. This rule, however, gives too high elongations for very strong steel.

A classification of steel according to the percentage of carbon which it contains and its capacity for taking temper or being welded, is as follows:

Soft, 0.05–0.20C,	not temperable, easily welded
Medium, 0.15–0.40C,	poor temper, weldable
Hard, 0.30–0.70C,	temperable, welded with difficulty
Very hard, 0.60–1.00C,	high temper, not weldable

It is seen that these classes overlap so that there is no distinct line of demarcation, and in fact the words soft, medium, and hard, are frequently used without precision and only for comparative purposes. The term 'strong steel' in the two preceding chapters has been introduced for educational purposes only, in order to divide steel into two classes for the benefit of beginners in engineering.

Steel is frequently classified, with reference to its uses, and the following is such a classification giving average elastic limits

and ultimate tensile strengths in pounds per square inch and ultimate elongations in percentages. For the elastic limit a variation of about 2 000 and for the ultimate strength a varia-

	Elastic Limit	Tensile Strength	Elongation
Structural steel			
for rivets	30 000	55 000	30
for beams and shapes	35 000	60 000	27
Boiler steel			
for rivets	25 000	50 000	30
for plates	30 000	60 000	26
Machinery steel	40 000	75 000	20
Gun steel	50 000	90 000	18
Axle steel	55 000	100 000	15
Spring steel	60 000	125 000	12
Cable wire steel	100 000	200 000	8

tion of 4 000 or 5 000 pounds per square inch from these mean values may be expected. The ultimate elongations are subject to marked variation according to the ratio of the length of the test specimen to its diameter; those here given are for the standard 8-inch specimen (Art. 169). In Fig. 169*a* are shown an unbroken and two broken specimens of the 2-inch size which has been much used since 1900; this gives higher percentages of elongation than the 8-inch specimen.

The soft and medium steels resemble wrought iron in having a yield point (Art. 11) which is from 2 000 to 4 000 pounds per square inch above the elastic limit, while very hard steels have no yield point, as the stress diagrams in Fig. 11*a* show. The elastic limit in tension is a little higher than one-half of the ultimate strength. The modulus of elasticity is subject to but little variation with the percentage of carbon, and the mean value of 30 000 000 pounds per square inch may be used in computations for both tensile and compressive stresses that do not exceed the elastic limit. The modulus of elasticity for shearing is about three-eighths of that for tension and compression. Soft and medium steel will withstand a cold-bend test similar to that described in the last article, but some of the hard steels will fail to do so on account of their lack of ductility.

The compressive strength of the soft steels may be said to be about the same as the tensile strength, since when this pressure is reached the shortened specimen is badly cracked. The soft steels resemble wrought iron in being plastic under compressive stress exceeding the elastic limit, and some authorities regard the yield point as the compressive strength. Hard steels, on the other hand, are not plastic beyond the elastic limit, but their behavior is like that of brittle materials (Art. 18). The compressive strength of the hard steels is much higher than the tensile strength and in this respect they resemble cast iron; the greatest value recorded is 392 000 pounds per square inch. The shearing strength of steel is usually about eighty percent of the tensile strength.

The strength of steel may be greatly increased by the processes of forging and drawing. Forging under a hammer or press renders the material more compact and increases both specific gravity and strength. The process of drawing steel bars into wire has a similar result, and wire has been made having a tensile strength of 250 000 pounds per square inch, while the wire used for the cables of suspension bridges usually has a tensile strength of from 150 000 to 200 000 pounds per square inch. By compressing steel while it is fluid, the strength may also be much increased, and this process is used for the steel from which large guns and hollow shafts are made.

Annealing consists in raising cold steel to a light red heat and then allowing it to cool for several days. This process reduces the ultimate strength, but it increases the ductility. As an example, the following table gives some of the results from a large series of specimens prepared by the Bethlehem Steel Company in 1893 and now kept at Lehigh University; the table refers to flat bars of Bessemer steel. Art. 119 shows that annealing increases the capacity of steel to resist work.

Tempering consists in plunging heated steel into a bath of water or oil, or by applying these fluids to its surface. The hardness of the steel and its ultimate strength are thereby much increased. Armor plate undergoes special processes of temper-

ing or carbonization which render it excessively hard and tough in order that it may resist projectiles which strike it.

Percent of Carbon	Tensile Strength Pounds per Square Inch		Ultimate Elongation Percentage	
	Unannealed	Annealed	Unannealed	Annealed
	0.08	58 000	56 000	27
0.25	84 000	75 000	21	25
0.50	125 000	99 000	11	19
0.67	136 000	112 000	6	16
1.04	153 000	128 000	3½	11

Steel castings are extensively used for axle boxes, cross-heads, and machine frames. They range in tensile strength from 60 000 to 90 000 pounds per square inch and have an elastic limit of somewhat less than half the ultimate strength. Although less reliable than steel forgings, they give excellent service after having been annealed so as to increase their ductility and their capacity to withstand shock and work.

Steel is alloyed with chromium, manganese, tungsten, and other materials in order to increase its strength, hardness, and toughness. Modern tool steels contain from five to ten percent of tungsten, which enables the tool to retain its temper even when under a red heat. Nickel is much used as an alloy for the steel of guns and armor plates. Nickel steel has been used to a slight extent for structural purposes and for railroad rails; it contains about 3¼ percent of nickel, and has an elastic limit of about 48 000 and a tensile strength of about 90 000 pounds per square inch. Nickel steel has been made with an elastic limit of 120 000 and a tensile strength of 277 000 pounds per square inch, the ultimate elongation being about 3 percent.

Prob. 25a. If steel costs 3 cents per pound and nickel costs 35 cents per pound, what should be the cost of a pound of nickel steel which contains 3.25 percent of nickel?

Prob. 25b. Consult Campbell's paper on Tensile Strength of Open-Hearth Steel, in Transactions of American Institute of Mining Engineers, 1905, and test his Table XVII by the above formulas.

ART. 26. OTHER MATERIALS

Several kinds of artificial stone have been made since 1870, most of them having hydraulic cement and sand as the principal ingredients. Beton consists only of those materials which are subject to prolonged trituration, so that its strength is much greater than ordinary concrete. Frear stone is made from cement and sand with a small quantity of gum shellac. Ransome stone is made from sand and sodium silicate which are thoroughly incorporated in molds and then the blocks are put under pressure in a hot solution of calcium chloride. Sand-lime brick, which has been extensively made since 1900, is an artificial stone made by consolidating heated sand and lime under pressure. These artificial stones are used mainly for the walls of buildings, for window lintels, and for steps.

Ropes are made of hemp, of manilla, and of iron or steel wire with a hemp center. A hemp rope one inch in diameter has an ultimate strength of about 6 000 pounds, and its safe working strength is about 800 pounds. A manilla rope is slightly stronger. Iron and steel ropes one inch in diameter have ultimate strengths of about 36 000 and 50 000 pounds respectively, the safe working strengths being 6 000 and 8 000 pounds. As a fair rough rule, the strength of ropes may be said to vary as the squares of their diameters, that is, with the areas of the cross-sections.

Phosphor bronze is an alloy of copper and tin containing from 2 to 6 percent of phosphorus. It is remarkable for its complete fluidity so that most perfect castings can be made. It has been used for journal bearings, valve seats, and even for cannon. It is hard and tough, and its ultimate tensile strength may range from 40 000 to 100 000 pounds per square inch.

Aluminum is a silver-gray metal which is malleable and ductile and not liable to corrode. Its specific gravity is about 2.65, so that it weighs only 168 pounds per cubic foot. Its ultimate tensile strength is about 25 000 pounds per square inch. It has a low modulus of elasticity, and its ultimate elongation is small. Alloys of aluminum and copper have been made with a tensile

strength and elongation exceeding those of wrought iron, but have not come into use as structural materials.

Numerous brasses and bronzes composed of copper, tin, and zinc have been made. The strongest of these alloys was ascertained by Thurston to be that composed of 55 parts of copper, 43 of zinc, and 2 of tin, its ultimate tensile strength being 68 900 pounds per square inch with an elongation of 48 per cent and a reduction of area of 70 percent.

Brass, which is composed of copper and zinc, is almost the only alloy which has come into extensive use in the arts and which at the same time is a fully reliable material. In the form of castings it has a tensile strength of about 20 000 pounds per square inch, in the form of rolled sheets or wire it has a much greater strength. Brass water-pipes are now frequently used in houses by those who can afford to pay as high a price as 20 cents per pound.

The tensile strength of lead is only about one-tenth of that of brass, and it attains a permanent set under a very low stress; it is indeed almost devoid of elasticity, but has high plasticity. Glass is very brittle, but under slowly applied loads it has a tensile strength of about 5 000 and a compressive strength of about 8 000 pounds per square inch. Anthracite coal is a brittle material, having a compressive strength of from 5 000 to 15 000 pounds per square inch.

In conclusion it may be noted that the strength and other properties of materials are subject to variation with temperature, the mean values given in the preceding pages being for a temperature ranging from 40 to 90 degrees Fahrenheit. Experiments have shown that wrought iron and steel continually increase in strength under static loads with decreasing temperatures, the rate of increase being about four percent for each 100 degrees of decrease in temperature. This rule applies for all ordinary temperatures to which structures and machinery are subjected, and to temperatures below 200 degrees Fahrenheit. As the temperature rises above 200°, wrought iron and steel increase in strength, attaining a maximum at about 500° and a rapid decrease

then follows for higher temperatures; the elastic limit, however, seems continually to decrease as the temperature rises. Steel and other metals are more brittle at low temperatures than at high ones, and the breaking of railroad rails in cold weather is attributed to brittleness and not to decrease in static strength.

Prob. 26*a*. A bar of aluminium copper, $1\frac{1}{4} \times 1\frac{3}{8}$ inches in section area, breaks under a tension of 42 800 pounds. What tension will probably break a bar of the same material which is $1\frac{7}{8} \times 2\frac{1}{4}$ inches in section area?

Prob. 26*b*. Compute the factor of safety of a cast-iron block, 2×2 feet in section area, when supporting a load of 2 165 net tons. What should be the size of a white-oak block to carry the same load with a factor of safety of 10?

CHAPTER IV

CASES OF SIMPLE STRESS

ART. 27. STRESS DUE TO OWN WEIGHT

Tension, compression, and shear are often called the three cases of simple stress, it being understood that the body or bar is under only one of these stresses at the same time: In tension and compression the loads act along the axis of the bar, in shear they act normally to it. When a bar is vertical, its weight causes stresses additional to those arising from the applied load, and these will now be considered.

When an unloaded bar is hung vertically by one end, there is no stress on the lower end, while at the upper end there is a tensile stress equal to the weight of the bar. When a vertical bar of weight W has a load P at its lower end, the tensile stress at that end is P and that at the upper end is $P+W$. In many practical cases W is small compared with P , so that it is unnecessary to consider it; a common rule is that the stress due to W need not be regarded when it is less than ten percent of that due to P . A steel bar one square inch in section area and 30 feet long weighs about 102 pounds (Art. 17), and a stress of 100 pounds per square inch is small compared with the elastic limit of the material.

The limiting length of an unloaded vertical bar is that at which it would break at the upper end under its own weight. Let a be the section area of the bar, S the ultimate strength of the material, v its weight per cubic unit, and l the limiting length. Then the weight of the bar is val , the tensile stress at its upper end is aS , and hence for rupture $S=vl$, whence $l=S/v$. For example, take a cast-iron bar for which $S=20\ 000$ pounds per square inch or 2 880 000 pounds per square foot, and $v=450$ pounds per cubic foot; then the limiting length is $l=2\ 880\ 000/450=6\ 400$ feet. Of course, no vertical bar of this length is possible.

The limiting length of a vertical bar loaded at its lower end is that at which it would break at the upper end under the stress due to the load and its own weight. If P is the load at the lower end, the stress at the upper end is $P+val$, and hence for rupture $Sa=P+val$, from which $l=(S-P/a)/v$. Hence P/a is the unit-stress due to P , and the formula shows that l is zero when P/a equals the ultimate tensile strength of the material. For a cast-iron bar let P/a be 10 000 pounds per square inch, then the limiting length is 3 200 feet.

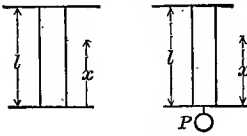

Fig. 27a

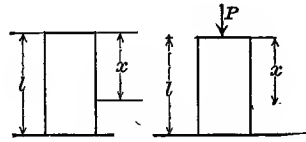

Fig. 27b

The elongation of a vertical bar under its own weight is one-half of that caused by the same load applied at the lower end. To show this, let l be the length, a the section area, and W the weight of the bar. Let x be any distance from the lower end (Fig. 27a), then $W \cdot x/l$ is the weight of this portion. The elementary elongation caused by this weight on the elementary length δx is from (10) given by $W(x/l)\delta x/aE$, where E is the modulus of elasticity. The integral of this between the limits l and 0 gives $e=\frac{1}{2}Wl/aE$, which is one-half the elongation due to a load W at the end (Art. 10). In a similar manner the elongation due to the weight of the bar and a load P at the end is found to be $e=(\frac{1}{2}W+P)l/aE$, and this is the sum of the separate elongations due to W and P . These expressions apply also to the corresponding cases of compression shown in Fig. 27b, but here, as in tension, the formulas apply only when the greatest unit-stress does not exceed the elastic limit of the material.

Prob. 27a. Find the length of a vertical wooden bar, 6×6 inches in section area and having a load of 21 600 pounds at the lower end, so that the stress at the upper end shall be 650 pounds per square inch.

Prob. 27b. Compute the elongation of the above bar due to the load at the end and that due to its own weight.

ART. 28. BAR OF UNIFORM STRENGTH

A suspension rod of constant cross-section is stressed at the lower end by the load P , and at the upper end by P plus the weight of the rod. When the rod is very long its section area should be less at the lower than at the upper end in order both to economize material and to reduce its weight. The rod in such cases is sometimes made in parts, the section area of any part being less than that of the one above it.

A vertical tension bar of uniform strength is one in which the unit-stress is the same in all section areas. The theoretic form for such a bar will now be determined.

Let P be the load applied at the lower end, and S the allowable unit-stress; then the section area of the lower end is $a_0 = P/S$. Let a be the section area at a distance y from the lower end; then

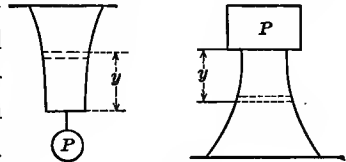

Fig. 28

Let a be the section area at a distance y from the lower end; then $a + \delta a$ is the area at the distance $y + \delta y$, and the area δa must be sufficient to resist the stress due to the weight of the bar in the distance δy . Let v be the weight of a cubic unit of the material, then the weight of the bar in the distance δy is $va \cdot \delta y$, and hence $\delta a = (va \cdot \delta y)/S$, which may be written $\delta y = (S/v)(\delta a/a)$. Integrating this and determining the constant by the condition that a equals a_0 when y is 0, there is found,

$$y = (S/v)(\log_e a - \log_e a_0)$$

in which the logarithms are in the Napierian system. Passing to common logarithms by the well-known rules, this becomes,

$$\log a = 0.4343(v/S)y + \log a_0$$

which is the formula for computing a at any distance y from the lower end, a_0 being first found from $a_0 = P/S$. This formula applies to compression as well as to tension, and the second diagram in Fig. 28 illustrates this case.

For example, take a round masonry pier which is to carry a load of 900 000 pounds with an allowable working stress of 100 pounds per square inch or 14 400 pounds per square foot.

The area of the top is $a_0 = 900/14.4 = 62.5$ square feet, and $v/S = 160/14,400 = 0.01111$. The formula then becomes $\log a = 0.00482y + 1.7959$. The following values of the section area

$y = 0$	10	20	30	40 feet
$a = 62.5$	69.8	78.0	87.2	97.4 square feet
$d = 8.92$	9.43	9.97	10.54	11.14 feet

and the diameter of the pier are now computed for different values of the height y , and it is seen that the profile of the pier is slightly curved. The extra expense of construction of a pier of uniform strength is, however, usually greater than that of the extra amount of material of a trapezoidal profile, so that the latter is generally used. A round pier with trapezoidal profile carrying the same load as above with a working stress of 100 pounds per square inch on top and base, requires a section area of 97.8 square feet at the base.

Prob. 28. A vertical steel rod of a mine pump which is to carry a load of 40 000 pounds at its lower end, is required to have no stress greater than 6 000 pounds per square inch, its length being 185 feet. Compute its section area if it is of uniform size. Compute the section area at the upper end if it could be made of uniform strength.

ART. 29. ECCENTRIC LOADS

In all the discussions of the preceding articles the resultant of the tensile or compressive load on a bar has been supposed to coincide in direction with the axis of the bar and the unit-stress produced by it to be uniformly distributed over each section area (Art. 1). This is the common case of simple axial stress, but there are also cases where the load is 'eccentric', that is, it does not coincide with the axis; the effect of this is to cause the unit-stress to be greater on one side of the section than on the other. If P is the load on a bar and a is its section area, then for axial loads P/a is the actual uniform unit-stress; for eccentric loads P/a is a mean or average value, some of the unit-stresses being greater and others being less than P/a .

Fig. 29*a* shows part of a rectangular bar where the eccentric tensile load P is applied at the distance p from the axis of the

bar and in the middle of the width of the section, and Fig. 29*b* shows the same bar under compression. At any section *mn* the resisting unit-stresses act in the opposite direction to *P* and hold it in equilibrium. The resultant of these unit-stresses must equal the load *P* in order that there may be no motion in the direction of the length of the bar, and it must be in the same line of action as *P* in order that there may be no motion of rotation. From these two conditions of equilibrium (Elements of Mechanics, Art. 5) the values of the greatest unit-stress *S*₁ and the least unit-stress *S*₂ can be found when the law of variation of the stresses across the section is known.

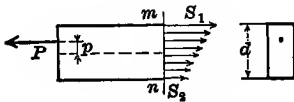

Fig. 29*a*

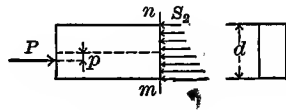

Fig. 29*b*

It has been ascertained by experiment that, when the elastic limit of the material is not exceeded the stresses increase across the section at a uniform rate from *S*₂ to *S*₁, and hence the law of variation is that of a straight line. From this law, the mean unit-stress is $\frac{1}{2}(S_1 + S_2)$ and the total stress on the section area *a* is $\frac{1}{2}(S_1 + S_2)a$; accordingly the first condition of equilibrium is expressed by $\frac{1}{2}(S_1 + S_2)a = P$. To express the second condition, it may be noted that the resultant load *P* must be opposite to the center of gravity of the trapezoid which represents the unit-stresses; or conversely, the center of gravity of this trapezoid must be at the distance *p* above the axis of the bar in Fig. 29*a* and at the distance *p* below the axis in Fig. 29*b*. Let *d* be the width of the rectangular section; then it is known that the center of gravity of the trapezoid having the two parallel sides *S*₁ and *S*₂ and the altitude *d* is given by $p = \frac{1}{3}d(S_1 - S_2)/(S_1 + S_2)$. Solving these two equations there results,

$$S_1 = \frac{P}{a} \left(1 + 6 \frac{p}{d} \right) \quad S_2 = \frac{P}{a} \left(1 - 6 \frac{p}{d} \right) \quad (29)$$

from which the unit-stresses may be computed for any given value of the eccentricity *p*. When *p* = 0, both *S*₁ and *S*₂ are equal to *P*/*a* and the stress is uniformly distributed.

The following figures show the distribution of the unit-stresses for several cases of compression, the cross-section of each prism being rectangular and having the width d . In Fig. 29c the load is axial or $p=0$ and $S_1=S_2=P/a$. In Fig. 29d the distance p is less than $\frac{1}{6}d$ and the values of S_1 and S_2 are given by the above formulas. In Fig. 29e the distance p is $\frac{1}{6}d$ and the formulas give $S_1=2P/a$ and $S_2=0$, so that the unit-stress on the side of the section nearest P is double that of uniform distribution, while there is no stress on the other side. In Fig. 29f the distance p is greater than $\frac{1}{6}d$, so that S_1 is greater than $2P/a$, while S_2 is negative, that is, S_2 is tension instead of compression. As a numerical example, let a masonry pier having a base 10×30 feet, as in Fig. 29g, carry a load of 1 200 000 pounds on its top at a distance of 6 feet from the middle. Here $P/a=1\ 200\ 000/300=4\ 000$ pounds per square foot $=28$ pounds per square inch, and $p/d=6/30=0.2$. Accordingly the greatest compressive stress due to this eccentric load is $S_1=28(1+1.2)=62$ pounds per square inch, while the stress on the other side is $S_2=28(1-1.2)=-6$ pounds per square inch tension.

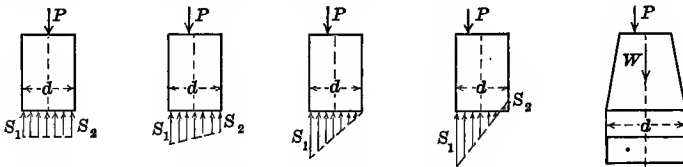

Fig. 29c

Fig. 29d

Fig. 29e

Fig. 29f

Fig. 29g

The above investigation considers only the stresses caused by the eccentric load and takes no account of those due to the weight of the bar or prism itself. If this weight be W the uniform unit-stress due to it is W/a , and this may be added to those caused by the eccentric load P . For instance, let the pier in the above example weigh 1 500 000 pounds; then $W/a=35$ pounds per square inch, so that the greatest and least compressive stresses due to both P and W are $S_1=35+62=97$ and $S_2=35-6=29$ pounds per square inch.

When the load on a rectangular prism has no eccentricity, the stress on each section is uniformly distributed and hence all

parts of the prism suffer the same change of length. For an eccentric load, the stresses vary throughout the section, and hence the changes in length are not uniform; thus in Fig. 29*e* the left-hand side shortens the amount S_1/E for every unit of length (Art. 10), while the right-hand side suffers no change of length; again in Fig. 29*f* the left-hand side shortens but the right-hand side elongates. The result of these unequal changes of length is to cause the prism or bar to bend laterally, and this lateral deflection is discussed in Arts. 86–87, where also formulas for cross-sections of any shape are deduced.

Prob. 29*a*. A rectangular wooden block is 6×16 inches in section area and 18 inches high. It carries two loads applied on the top at the middle of the width of the cross-section, P_1 being 2 inches from the center, while P_2 is 3 inches from the center but on the side opposite P_1 . Compute the ratio of P_1 to P_2 so that the unit-stress may be uniform over the base.

ART. 30. WATER AND STEAM PIPES.

The pressure of water or steam in a pipe is exerted in every direction as shown in the transverse section of Fig. 30*a*; this tends to tear the pipe apart longitudinally and it is resisted by the tensile stresses of the material. Let R be the pressure per unit of area which is exerted by the water or steam, d the diameter of the pipe,

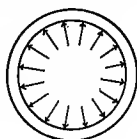
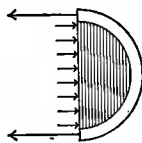
Fig. 30*a*Fig. 30*b*

and l its length. Then the force which tends to cause longitudinal rupture is $ld \cdot R$; this follows from the principle of hydrostatics that the pressure of a fluid or gas in any direction is equal to the pressure on a plane normal to that direction, or it may be shown by imagining the pipe to be filled with a solid substance on one side of the diameter, as in Fig. 30*b*, which receives the pressure R on each unit of the area ld . Let t be the thickness of the pipe and S the resisting tensile unit-stress; when t is small compared with d the tensile stress may be regarded as uniformly distributed and then the total resisting stress is $2lt \cdot S$. Since the resisting

stress must equal the acting pressure, it follows that,

$$2tS = dR \quad \text{or} \quad S/R = d/2t \quad (30)$$

which is the common formula for pipes under internal pressure.

The unit-pressure R for water may be computed from a given head h by finding the weight of a column of water of that height and one square unit in section. Or, if h be given in feet, the unit-pressure in pounds per square inch may be computed from $R = 0.434h$ (Treatise on Hydraulics, Art. 11).

Pipes are made of cast iron, wrought iron, and steel. Cast iron is used for water pipes up to 36 inches in diameter, and steel is generally used for steam pipes. Large water pipes are made of steel plates riveted together, but the discussion of these is reserved for another article. A water pipe subject to the shock of water ram requires a high factor of safety, and in a steam pipe the factors should also be high owing to the shocks liable to occur from the condensation and expansion of the steam. The above formula shows that the thicknesses of thin pipes of the same material under the same internal pressure should increase directly as their diameters. Thick pipes are treated in Art. 150.

For example, let it be required to find the factor of safety of a cast-iron water pipe of 12 inches diameter and $\frac{5}{8}$ inches thickness under a head of 300 feet. Here R is $0.434 \times 300 = 130.2$ pounds per square inch. Then the unit-stress is

$$S = 12 \times 130.2 / (2 \times \frac{5}{8}) = 1250 \text{ pounds per square inch}$$

and hence the factor of safety of the cast iron under this tensile stress is $20000/1250 =$ about 16, which indicates ample security under ordinary conditions.

Again, let it be required to find the proper thickness for a wrought-iron steam pipe of 18 inches diameter to resist a pressure of 120 pounds per square inch. With a factor of safety of 10 the working unit-stress S is about 5000 pounds per square inch. Then from the formula the required thickness is $t = (120/5000) \times 9 = 0.22$ inches. In order safely to resist the shocks liable to occur in handling the pipes, the thickness is often made greater than the above formula requires.

Prob. 30a. What should be the thickness of a cast-iron water pipe of 18 inches diameter under a head of 300 feet, the factor of safety being taken as 15?

Prob. 30b. A wrought-iron pipe is 3 inches in internal diameter and weighs 8 pounds per linear foot. Compute its thickness, and the pressure it can carry with a factor of safety of 10.

ART. 31. THIN CYLINDERS AND SPHERES

A cylinder subject to the interior pressure of water or steam tends to fail longitudinally exactly like a pipe. The head of the cylinder, however, undergoes a pressure which tends to separate it from the walls. If d is the diameter of the cylinder and R the internal pressure per square unit, the total pressure on the head is $\frac{1}{4}\pi d^2 \cdot R$. If S is the working unit-stress and t the thickness of the cylinder, the resistance to the pressure is approximately $\pi dt \cdot S$ when t is so small that S may be regarded as uniformly distributed. Since the resisting stress must equal the acting pressure,

$$\pi dt \cdot S = \frac{1}{4}\pi d^2 \cdot R \quad \text{or} \quad S/R = d/4t$$

By comparing this with the formula of the last article it is seen that the resistance of a pipe to transverse rupture is double the resistance to longitudinal rupture.

A thin sphere subject to interior pressure tends to rupture around a great circle, and it is easy to see that the conditions are exactly the same as for the transverse rupture of a cylinder, or that $4tS = dR$. For thick spheres and cylinders the formulas of this and the last article are only approximate; a full discussion of these will be found in Arts. 150, 152, 163.

A cylinder under exterior pressure is theoretically in a similar condition to one under interior pressure as long as it remains a true circle in cross-section. A uniform interior pressure tends to preserve and maintain the circular form of the cylindrical annulus, but an exterior pressure tends at once to increase the slightest variation from the circle and render it elliptical. The distortion when once begun rapidly increases, and failure occurs by the collapsing of the tube rather than by the crushing of the

material. The flues of a steam boiler are the most common instance of cylinders subjected to exterior pressure. In the absence of a rational method of investigating such cases recourse has been had to experiment. Tubes of various diameters, lengths, and thicknesses have been subjected to exterior pressure until they collapse and the results have been compared and discussed. The following, for instance, are the results of three experiments by Fairbairn on wrought-iron tubes, the collapsing pressure being in pounds per square inch:

Length	37	60	61	inches
Diameter	9	$14\frac{1}{2}$	$18\frac{3}{4}$	inches
Thickness	0.14	0.125	0.25	inches
Unit-pressure	378	125	420	

From these and other similar experiments it has been concluded that the collapsing unit-pressure varies directly as some power of the thickness, and inversely as the length and diameter of the tube. For wrought-iron tubes Wood gives the empirical formula for the collapsing pressure per square inch,

$$R = 9\ 600\ 000 t^{2.18} / ld$$

and the values of R computed from this formula for the above three experiments are 397, 120, and 409 pounds per square inch, which agree well with the observed values.

The proper thickness of a wrought-iron tube to resist exterior pressure may be readily found from this formula after assuming a suitable factor of safety. For example, let it be required to find t when $R = 120$ pounds per square inch, $l = 72$ inches, $d = 4$ inches, and the factor of safety = 10. Then the formula gives $t^{2.18} = 0.036$ from which, with the help of logarithms, the thickness t is found to be 0.22 inches.

Prob. 31a. What interior pressure per square inch will burst a cast-iron sphere of 24 inches diameter and $\frac{3}{4}$ inches thickness?

Prob. 31b. What exterior pressure per square inch will collapse a wrought-iron tube 72 inches long, 4 inches diameter, and 0.25 inches thickness? What is a proper thickness for this tube under a steam pressure of 150 pounds per square inch?

ART. 32. SHRINKAGE OF HOOPS

Hoops and tires are frequently turned with the interior diameter slightly less than that of the wheels or cylinders upon which they are to be placed. A hoop is expanded by heat and placed in position, and in cooling it shrinks and is held firmly upon the cylinder by the radial pressure caused by the shrinkage. The effect of this radial pressure is to cause tension in the hoop, and compression throughout the mass that it encircles.

When the hoop is thin compared to the diameter of the cylinder upon which it is shrunk, the entire deformation due to the shrinkage may be practically regarded as confined to the hoop. The tangential unit-stress in the hoop will then be due only to the increase in length of the circumference, and this will be proportional to the increase in its diameter. If ϵ is the unit-elongation of the hoop and E the modulus of elasticity of the material, then by (9) the tensile unit-stress due to the elongation is $S = \epsilon E$.

Let d be the diameter of the cylinder upon which the hoop is to be shrunk, and d_1 be the interior diameter to which the hoop is turned. Supposing that d is unchanged by the shrinkage, d_1 will be increased to d , and the unit-elongation of the inner circumference of the hoop will be $\epsilon = (d - d_1)/d_1$; since the hoop is thin, this is practically the unit-elongation for all parts of the hoop. Accordingly,

$$S = \epsilon E \quad \text{or} \quad S = \frac{d - d_1}{d_1} E$$

is the tensile unit-stress in the hoop due to shrinkage.

A common rule for the case of steel hoop shrinkage is to make $d - d_1$ equal to $\frac{1}{1500}d$, that is the hoop is turned so that its interior diameter is $\frac{1}{1500}$ th less than the diameter of the cylinder; then $d_1 = \frac{1499}{1500}d$, and $\epsilon = (d - d_1)/d_1 = \frac{1}{1499}$, which is practically the same as $\frac{1}{1500}$. The tangential tensile unit-stress in the hoop then is $S = 30\,000\,000 / 1\,500 = 20\,000$ pounds per square inch.

The radial unit-stress acting between the cylinder and the hoop is from formula (30) readily found to be $R = 2tS/d_1$, and

hence its value depends upon the diameter of the cylinder and the thickness of the hoop. For a locomotive driving wheel having $d=60$ inches, $t=\frac{3}{4}$ inches, and $S=20\,000$ pounds per square inch, the radial unit-pressure R between the tire and wheel is 500 pounds per square inch.

The above discussion gives values of S somewhat too high, because the radial pressure acting between the hoop and the cylinder produces some decrease in the diameter of the latter. For thick hoops upon hollow cylinders, such as those of large guns, the above method is not sufficiently accurate, and a more exact one is given in Art. 152.

Prob. 32. Upon a cylinder 18 inches in diameter a wrought-iron hoop 2 inches thick is to be placed. The hoop is turned to an interior diameter of 17.98 inches and shrunk on. Compute the tensile unit-stress in the hoop.

ART. 33. INVESTIGATION OF RIVETED JOINTS

When two overlapping plates are fastened together with one row of rivets, as in Fig. 33*a*, the joint is called a lap joint with single riveting; when two rows are used, as in Fig. 33*b*, it is said to be a lap joint with double riveting. When tension is transmitted through such plates, its first effect is to bring a side-wise compression on the rivet, and this in turn brings a shear on the rivet which tends to cut it off in the plane of the surfaces of junction of the plate. The exact manner in which the side-wise compression acts upon the cylindrical surface of the rivet is not known, but it is usually supposed that it causes a compressive stress which is uniformly distributed, over the projection of that surface upon a plane through the axis of the rivet.

For a lap joint with single riveting, as in Fig. 33*a*, let P be the tensile force which is transmitted from one plate to another by means of a single rivet, t the thickness of the plate, and p the pitch of the rivets. Let S_t be the tensile unit-stress which occurs in the section of the plate between two rivets, and S_c and S_s be the unit-stresses of compression and shear upon a rivet. Then the equations between the stresses and the force P are,

$$\begin{array}{ll} \text{for tension on plate,} & t(p-d)S_t = P \\ \text{for compression on rivet,} & tdS_c = P \\ \text{for shear on rivet,} & \frac{1}{2}\pi d^2 \cdot S_s = P \end{array}$$

From these equations the unit-stresses may be computed when the other quantities are known, and by comparing them with the proper allowable unit-stresses (Art. 7) the degree of security of the joint is estimated.

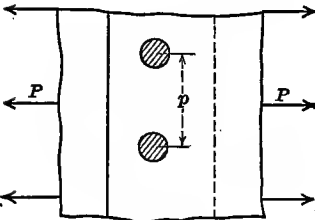
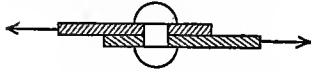

Fig. 33a

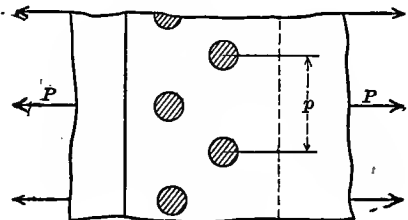
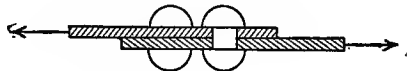

Fig. 33b

For a lap joint with double riveting, the plates have a wider lap, and the two rows of rivets are staggered, as in Fig. 33b. Let P be the tension which is exerted over the width equivalent to the pitch p , this being the distance between the centers of two rivets in one row. Then P is transferred from one plate to another through two rivets, and the three formulas are,

$$t(p-d)S_t = P \quad 2td \cdot S_c = P \quad 2 \cdot \frac{1}{2}\pi d^2 \cdot S_s = P$$

from which the unit-stresses due to the tension P may be computed and the security of the joint be investigated. This joint is usually a stronger one than that with single riveting, if proper values are assigned to p and d .

The investigation of a given riveted joint consists in determining the values of S_t , S_s , and S_c from the above equations and then computing the factors of safety (Art. 7). For example take a lap joint with double riveting where $P = 8000$ pounds, $p = 2\frac{1}{2}$ inches, $d = \frac{7}{8}$ inches, and $t = \frac{3}{4}$ inches. Then the tensile stress on the plate between two rivets is,

$$S_t = P/t(p-d) = 6560 \text{ pounds per square inch,}$$

while the sidewise compressive stress on the rivet is,

$$S_c = P/2td = 6\ 100 \text{ pounds per square inch,}$$

and the shearing stress on the rivet is,

$$S_s = P/\frac{1}{2}\pi d^2 = 6\ 650 \text{ pounds per square inch.}$$

Now, if these plates and rivets be of structural steel having an ultimate tensile and compressive strength of 55 000 pounds per square inch and an ultimate shearing strength of 45 000 pounds per square inch, the factors of safety are 8.4 for the plate in tension, 9.0 for the rivet in compression, and 6.8 for the rivet in shear.

The 'efficiency' of a joint is defined as the ratio of its highest allowable stress to the highest allowable stress of the unriveted plate. For any riveted joint three efficiencies may be computed by dividing the three values of P by $pt \cdot S_t$, which is the allowable stress on the unriveted plate, and the smallest of these is the efficiency of the joint. For example, let $S_t = S_c = 55\ 000$, and $S_s = 45\ 000$ pounds per square inch, and let $p = 2\frac{1}{2}$, $d = \frac{7}{8}$, and $t = \frac{3}{4}$ inches for a lap joint with double riveting. Then for the plate in tension the efficiency is $(p-d)tS_t/ptS_t = (p-d)/p = 0.65$; for the rivet in compression the efficiency is $2tdS_c/ptS_t = 2dS_c/pS_t = 0.70$; and for the rivet in shear the efficiency is $\frac{1}{2}\pi d^2 S_s/ptS_t = 0.52$. The efficiency of this joint is therefore 0.52, that is, its strength is 52 percent of that of an unriveted plate. In a properly designed joint all parts are of equal strength and the three efficiencies are equal.

A butt joint is one in which there is no overlapping of the main plates, but cover plates are used. Fig. 33c shows a case

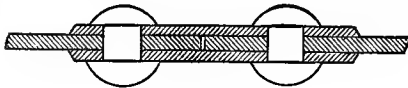

Fig. 33c

where there are two cover plates and a single row of rivets on each side of the joint. When tension is applied to the two main plates, it first produces compression on the rivets and this in turn brings the rivets into shear. This shear comes on two cross-sections of each rivet and transfers one-half of the applied tension into each cover plate. Accordingly the thickness of a cover plate should be one-half of that

of the main plate. Let the notation be the same as before; then,

$$P = t(p-d)S_t \quad P = tdS_c \quad P = 2 \cdot \frac{1}{4}\pi d^2 \cdot S_s$$

are the three formulas for the cases of tension, compression, and shear. Here the expressions for tension and compression are the same as those for a lap joint with single riveting, but that for shearing is different because the total stress is divided between two cross-sections of a rivet.

Butt joints having two cover plates, and two rows of rivets on each side, are also used. For this case it is easy to see that the three formulas are,

$$1. \quad t(p-d)S_t = P \quad 2. \quad td \cdot S_c = P \quad 4. \quad \frac{1}{4}\pi d^2 S_s = P$$

since the force P brings compression upon two rivets and shear upon four rivet sections. Here, as always, t is the thickness of the main plates and p is the pitch of the rivets in one row; the two rows are 'staggered', as shown in Fig. 33*b*, that is, the rivets of one row are opposite the middle of the pitch of the other row.

Prob. 33*a*. A boiler 36 inches in diameter carries a steam pressure of 120 pounds per square inch. Its longitudinal lap joints have a single row of rivets which are spaced with $1\frac{7}{8}$ inches pitch. Compute the tension P which brings shear upon one rivet.

Prob. 33*b*. The plates of this boiler are $\frac{3}{8}$ inches thick and the rivets are $\frac{1}{4}\frac{1}{8}$ inches in diameter. Compute the unit-stresses upon the plates and the rivets. What is the efficiency of the joint, and what steam pressure will cause the boiler to rupture?

ART. 34. DESIGN OF RIVETED JOINTS

The design of a riveted joint consists in giving such values to the plate thickness t , the diameter of the rivets d , and the pitch of the rivets p , that all parts may be of the same strength, and that the working unit-stresses may be such that the proper degree of security is obtained (Art. 7). For example, taking a double-riveted lap joint of structural steel, let it be required to determine t , d , and p so that $S_t = 9\,000$, $S_c = 12\,000$, and $S_s = 7\,500$ pounds per square inch when the tension P which comes on one rivet is 8 000 pounds. The third formula for this case (Art. 33) gives the value of d , then the second gives the value

of t , and finally the first gives the value of p . Thus $d^2 = 2P/\pi S_s$, whence $d = 0.825$ inches, $t = P/2dS_c = 0.404$ inches, and $p = d + P/tS_t = 3.025$ inches.

While the above results satisfy the given conditions, it is not practicable to use the exact values, because plates and rivets of these dimensions could not be found in the market and would have to be specially made. The nearest approach to market sizes would probably be $t = \frac{3}{8}$ inches and $d = \frac{1}{4}\frac{3}{8}$ inches, which give $p = 3.18$, or say $3\frac{3}{16}$ inches. Using these dimensions, the values of S_t , S_c , and S_s are found to be 9 000, 13 100, and 7 700 pounds per square inch, which differ but little from the specified working unit-stresses.

Another method of designing is to establish three expressions for the efficiency, and then give to t , d , and p such values as will render them equal, and at the same time carry the given tension. Let α denote the number of rivets in the width p which transmit the tension P , and let β denote the number of rivet sections in the same space over which the shear is distributed. Then from the definition of efficiency in the last article,

$$\begin{array}{ll} \text{for tension of the plate,} & \text{efficiency} = (p-d)/p \\ \text{for compression of the rivet,} & \text{efficiency} = \alpha \cdot dS_c/pS_t \\ \text{for shear of the rivet,} & \text{efficiency} = \beta \cdot \frac{1}{2}\pi d^2 S_s/p t S_s \end{array}$$

Equating now the second of these efficiencies to the third, the value of d in terms of t is found; equating the first and second and eliminating d , the value of p in terms of t is obtained; accordingly,

$$d = \frac{4\alpha S_c}{\pi\beta S_s} t \qquad p = \frac{4\alpha S_c}{\pi\beta S_s} \left(1 + \alpha \frac{S_c}{S_t}\right) t$$

from which the diameter and pitch of the rivets can be computed when t is assumed. The efficiency of the joint now is $(p-d)/p$ or $\alpha S_c/(S_t + \alpha S_c)$.

Using for steel plates and rivets the working stresses $S_t = 9\,000$, $S_c = 12\,000$, and $S_s = 7\,500$ pounds per square inch, the above formulas give for a riveted lap joint with single riveting, where $\alpha = 1$ and $\beta = 1$, the proportions,

$$d = 2.04t \qquad p = 4.75t \qquad \text{efficiency} = 0.57$$

so that if the thickness of the plate be given, and the diameter and pitch of the rivets be made according to these rules, this riveted joint has about 57 percent of the strength of the unholed plate. For a lap joint with double riveting, where $\alpha=2$ and $\beta=2$, the formulas become

$$d=2.04t \quad p=7.48t \quad \text{efficiency}=0.73$$

This investigation shows clearly the advantage of double over single riveting, and by adding a third row the efficiency will be raised to about 80 percent. In both cases the area $t(p-d)$ must be sufficient to carry the tension P under the unit-stress S_t .

The application of the above formulas to butt joints makes the diameter of the rivet equal to the thickness of the plate, and makes the pitch much smaller than the above values for lap joints. These proportions are difficult to apply in practice on account of the danger of injuring the metal in punching the holes. For this reason riveted joints are often made in which the strengths of the different parts are not equal. Many other reasons, such as cost of material and facility of workmanship, influence also the design of a joint. The old rules which are still sometimes used for determining the pitch in butt joints are expressed by,

$$p=d+\frac{\pi d^2}{2t} \quad \text{and} \quad p=d+\frac{\pi d^2}{t}$$

the first being for single and the second for double riveting. These are deduced by making the strength of the joint equal in tension and shear, and taking $S_s=S_t$, thus neglecting entirely the influence of the compression on the rivet.

The term 'bearing compression' is in common use for the sidewise compression brought upon a rivet by the tension in the plate. The assumption regarding its distribution is a rough approximate one and rivets are more apt to fail by shearing than by bearing compression. Hence it is customary to allow a higher working unit-stress for the bearing compression of a rivet than for the tension of a plate, notwithstanding that rivet steel is generally somewhat lower in strength than plate steel (Art. 25). Cooper's bridge specifications give 9 000 pounds per square

inch as the highest allowable stress for rivets in shear and 15 000 pounds per square inch for rivets in bearing compression.

It may be required to arrange a joint so as to secure either strength or tightness. For a bridge, strength is mainly needed; for a gasholder, tightness is the principal requisite; while for a boiler both these qualities are desirable. In general a tight joint is secured by using small rivets with a small pitch. The distance between the rows of rivets is determined by practical considerations. The lap of the plates should be sufficient so that the rivets may not tear or shear the plate. If the distance from the center of the hole to the edge of the plate be l , there are two areas tl along which shearing tends to occur, and $2tS_s$ must be equal to or greater than the tension P for a single-riveted joint, or l must be equal to or greater than $P/2tS_s$.

In the preceding discussion of the stresses on the rivet, it has been supposed that the compressive and shearing stresses act independently of each other. This assumption is the one commonly made in practice, but the investigations in Arts. 105 and 141 show that these stresses should really be combined in order to obtain the actual maximum stresses of compression and shear. The usual method of practice above explained in which liberal factors of safety are used is, however, generally regarded as one giving ample security.

Prob. 34*a*. A butt joint is like Fig. 33*c*, except that it has only one cover plate. What should be the thickness of this cover plate, and how does the joint differ from a single-riveted lap joint?

Prob. 34*b*. A lap joint with double riveting is to be formed of plates $\frac{1}{2}$ inch thick with rivets $\frac{7}{8}$ inches diameter. Find the pitch so that the strength of the plate shall equal the shearing strength of the rivets, and compute the efficiency of the structural-steel joint.

CHAPTER V

GENERAL THEORY OF BEAMS

ART. 35. DEFINITIONS

'Flexural Stress' occurs in a bar when it is in a horizontal position upon one or more supports. The weight of the bar and its loads cause it to bend, and induce in it stresses and deformations of a complex nature which, as will be seen later, may be resolved into those of tension, compression, and shear. Such a bar is called a 'Beam'.

A 'Simple Beam' is a bar resting upon supports near its ends. A 'Cantilever Beam' rests on one support at its middle, or the portion of any beam projecting out of a wall or beyond a support may be called a cantilever beam. A 'Continuous Beam' is a bar resting upon more than two supports. In this chapter the word beam, when used without qualification, includes all kinds, whatever be the number of the supports, or whether the ends be free, supported, or fixed. Fig. 35*a* shows a simple beam, Fig. 35*b* shows a cantilever beam, and Fig. 35*c* shows a continuous beam of two equal spans.

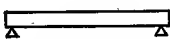
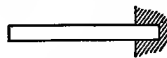
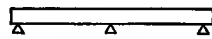
Fig. 35*a*Fig. 35*b*Fig. 35*c*

The 'Elastic Curve' is the curve formed by a beam as it deflects downward under the action of its own weight and of the loads upon it. Experience teaches that the amount of this deflection and curvature is very small. A beam is said to be 'fixed' at one end when it is so arranged that the tangent to the elastic curve at that end always remains horizontal; this may be done in practice by firmly building one end into a wall. A beam fixed at one end and free at the other end is a cantilever beam.

The loads on beams are either uniform or concentrated. A

'uniform load' embraces the weight of the beam itself and any load evenly spread over it. Uniform loads are estimated by their intensity per unit of length of the beam, and usually in pounds per linear foot. The uniform load per linear unit is designated by w , then wx will represent the load over any distance x ; if l is the length of the beam, the total uniform load is wl , which may be represented by W . A 'Concentrated Load' is a single applied weight and this is designated by P ; a moving concentrated load is usually applied by a rolling wheel.

In this chapter the fundamental principles applicable to all kinds of beams will be set forth. Unless otherwise stated, a beam will be regarded as of uniform cross-section throughout its entire length, and in computing its weight the rules of Art. 17 will be of service. For example, the weight of a wooden beam 6×8 inches in section area and 10 feet long is $6 \times 8 \times 3\frac{1}{8} \times 4\frac{1}{2} = 133$ pounds; the weight of a steel beam of the same size is $6 \times 8 \times 3\frac{1}{8} \times 10 \times 1.02 = 1632$ pounds.

Prob. 35a. Find the diameter of a round steel bar which weighs 60 pounds, its length being 5 feet.

Prob. 35b. A round steel bar of $2\frac{1}{8}$ inches diameter and 4 feet length weighs 48 pounds. What is the diameter of a cast-iron bar which has the same weight and length?

ART. 36. REACTIONS OF SUPPORTS

When a beam is laid upon supports its weight and the weight of its load are borne by the support which exert 'reactions' upward against the beam. In fact, the beam is a body in equilibrium under the action of a system of forces which consists of the downward loads and the upward reactions. The loads are usually given in intensity and position, and it is required to find the reactions. This is effected by the application of the fundamental conditions of static equilibrium which, for a system of vertical forces in one plane, are

$$\text{Algebraic sum of all vertical forces} = 0$$

$$\text{Algebraic sum of moments of all forces} = 0$$

The first of these conditions shows that the sum of all the loads

on the beam is equal to the sum of the reactions. Hence if there is but one support, this condition gives at once the reaction.

For two supports it is necessary to use the second condition. The axis of moments may be taken at any point in the plane, but it is more convenient to take it at one of the supports. For example, consider a single concentrated load P situated at 4 feet from the left end of a simple beam whose span is 13 feet. The equation of moments, with the axis at the left support, is $13R_2 - 4P = 0$, from which $R_2 = \frac{4}{13}P$. Again, the equation of moments, with the axis at the right support, is $13R_1 - 9P = 0$, from which $R_1 = \frac{9}{13}P$. As a check it may be observed that $R_1 + R_2 = P$.

For a uniform load over a simple beam it is evident, without applying the conditions of equilibrium, that each reaction is one-half the load. For a uniform load over the cantilever beam of Fig. 35*b* it is plain that the vertical reaction at the wall is equal to the weight of the load.

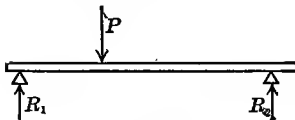
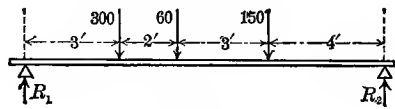
Fig. 36*a*Fig. 36*b*

The reactions due to both uniform and concentrated loads on a simple beam may be obtained by adding together the reactions due to the uniform load and each concentrated load, or they may be computed in one operation. As an example of the latter method let Fig. 36*b* represent a simple beam 12 feet in length between the supports and weighing 35 pounds per linear foot, its total weight being 420 pounds. Let there be three concentrated loads of 300, 60, and 150 pounds placed at 3, 5, and 8 feet respectively from the left support. To find the right reaction R_2 the axis of moments is taken at the left support, and the weight of the beam regarded as concentrated at its middle; then the equation of moments is,

$$R_2 \times 12 = 420 \times 6 + 300 \times 3 + 60 \times 5 + 150 \times 8$$

from which $R_2 = 410$ pounds. In like manner to find R_1 , the axis of moments is taken at the right support, and

$$R_1 \times 12 = 420 \times 6 + 300 \times 9 + 60 \times 7 + 150 \times 4$$

from which $R_1 = 520$ pounds. As a check the sum of R_1 and R_2 is found to be 930 pounds, which is the same as the weight of the beam and the three loads.

When there are more than two supports, the problem of finding the reactions from the principles of statics becomes indeterminate, since two conditions of equilibrium are only sufficient to determine two unknown quantities. By introducing, however, the elastic properties of the material, the reactions of continuous beams may be deduced, as will be explained in a following chapter. In most cases of the discussion of a beam, the determination of the reactions is the first step.

Prob. 36*a*. A simple beam weighing 30 pounds per linear foot is 18 feet long, and it carries two concentrated loads of 350 and 745 pounds at distances of $7\frac{1}{2}$ and 9 feet from the left end. Compute the reactions due to the total load.

Prob. 36*b*. When a single load P is on a simple beam of span l at a distance κl from the left support, show that the reactions are $R_1 = P(1 - \kappa)$ and $R_2 = P\kappa$.

ART. 37. THE VERTICAL SHEAR

The failure of a beam sometimes occurs by shearing in a vertical section as shown in Fig. 37*a* for a simple beam and in Fig. 37*b* for a cantilever beam. This shearing is produced by two equal and parallel forces acting in opposite directions on the left and right of the section. In the second diagram there acts on the left of the section a downward force equal to the sum of all the loads on the left, and on the right of the section an equal force acts upward. In the first diagram there acts on the left of the section an upward force which is equal to the reaction minus the weight of the beam between the support and the section. That such forces actually exist will be readily understood by considering a numerical case. Thus, for Fig. 37*a*, let the total weight of the beam and loads between the supports

be 1200 pounds, the weight between the support and the section mn be 50 pounds, and each reaction be 600 pounds; on the left of the section mn the upward vertical force is $600 - 50 = +550$ pounds, and on the right of the section the upward vertical force is $-1150 + 600 = -550$ pounds; here the sign $+$ indicates that the former force acts upward and the sign $-$ indicates that the latter acts downward. In any case, whether the beam be simple, cantilever, or continuous, let W indicate the total weight upon the supports, W' the weight on the left of any section and W'' the weight on the right of the section, or $W' + W'' = W$; also let R' indicate the sum of all the reactions on the left and R'' the sum of all the reactions on the right of the section, or $R' + R'' = W$. Then the vertical force on the left of the section is $R' - W'$ and that on the right of the section is $R'' - W''$; these two quantities are equal in magnitude, but they have opposite signs, since their sum is zero; accordingly if one acts upward the other acts downward and they constitute a shear (Art. 6).

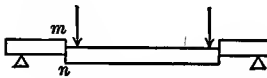

Fig. 37a

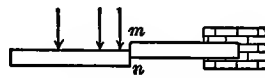

Fig. 37b

The 'Vertical Shear' for a section is the name given to the algebraic sum of all the external forces on the left of the section. Let upward forces be considered as positive and downward forces as negative, and let V denote the vertical shear for a given section; then,

$$V = \text{Reactions on left of section minus loads on left of section}$$

And the value of V may be positive or negative according as the reactions exceed or are less than the loads on the left. When V is positive, the left-hand part of the beam tends to slide upward with respect to the right-hand part, as in the section mn of Fig. 37a; when V is negative, the left-hand part tends to slide downward with respect to the right-hand part, as in the other section of Fig. 37a. In the cantilever beam of Fig. 37b, there is no reaction at the left, and hence the vertical shear at every section is negative.

The vertical shear varies greatly in value at different sections of a beam. Consider first a simple beam of length l and weighing w per unit of length; each reaction is then $\frac{1}{2}wl$. Pass a plane at any distance x from the left support; then from the definition, the vertical shear for that section is $V = \frac{1}{2}wl - wx$. Here it is seen that V has its greatest value $\frac{1}{2}wl$ when $x = 0$, that V decreases as x increases, and that V becomes 0 when $x = \frac{1}{2}l$. When x is greater than $\frac{1}{2}l$, the value of V is negative and becomes $-\frac{1}{2}wl$ when $x = l$. The equation $V = \frac{1}{2}wl - wx$ is that of a straight line in which x is the abscissa and V the ordinate, the origin being at the left support; it may be plotted so that the ordinate will represent the vertical shear for the corresponding section of the beam, as shown in Fig. 37c.

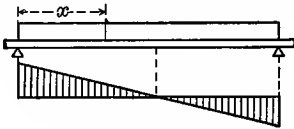

Fig. 37c

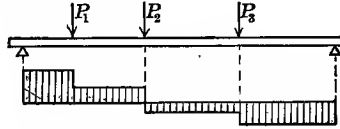

Fig. 37d

Consider again a simple beam, as in Fig. 37d, having a span of 12 feet with three loads of 240, 90, and 120 pounds, situated 3, 4, and 8 feet respectively from the left support. By Art. 36 the left reaction is found to be 280 and the right reaction 170 pounds. Then, for any section between the left support and the first load the vertical shear due to the given loads is $V = +280$ pounds, for a section between the first and second loads it is $V = 280 - 240 = +40$ pounds, for a section between the second and third loads it is $V = 280 - 240 - 90 = -50$ pounds, and for a section between the third load and the right support it is $V = 280 - 240 - 90 - 120 = -170$ pounds, which has the same numerical value as the right reaction. By laying off ordinates upon a horizontal line a graphical representation of the vertical shears due to the three concentrated loads is obtained.

For any section of a simple beam distant x from the left support, let R_1 denote the left reaction, w the weight of the uniform load per linear unit, and ΣP_1 the sum of all the concentrated loads between the section and the support. Then the

definition gives $V = R_1 - wx - \Sigma P_1$ as a general expression for the vertical shear. Thus if the beam of the last paragraph weighs 20 pounds per linear foot, the vertical shear at the left support is 400 pounds, while at two feet from the left support it is $400 - 40 = 360$ pounds. The student should compute vertical shears for other sections and draw the shear diagram.

The vertical shear for any section of a beam is a measure of the tendency to shearing along that section. The above examples show that this is greatest near the supports. It is rare that beams actually fail in this manner, but it is often necessary to investigate the tendency to such failure.

Prob. 37. The cantilever beam in Fig. 38*a* is 10 feet long and weighs 23 pounds per linear foot, while the load P is 60 pounds and is placed at 4 feet from the wall. Compute the vertical shears at several sections throughout the beam, and draw a diagram to show their distribution.

ART. 38. THE BENDING MOMENT

The usual method of failure of beams is by cross-breaking or transverse rupture. This is caused by the external forces producing rotation around some point in the section of failure. Thus, in Fig. 38*b* let l be the length of the cantilever beam and let m be the distance between P and the wall. Then the tendency of P to cause rotation around a point in the section at the wall is measured by its moment $-Pm$; if, however, the load is at the end, its tendency to produce rotation around the same point is measured by the moment $-Pl$. If w is the weight of this beam per linear unit, the uniform load wl produces the same tendency to rotation as if it were concentrated at its center of gravity (Elements of Mechanics, Art. 13); hence with respect to a section at the wall the moment of the uniform load wl is $-wl \times \frac{1}{2}l$.

Moments are taken as positive when they tend to cause rotation in the same direction as the hands of a clock, and negative when they tend to cause rotation in the opposite direction. When the force is in pounds and the lever arm is in feet, the moment

is in pounds-feet. For instance, let the beam of Fig. 38*b* be 10 feet long and weigh 23 pounds per linear foot, and let the concentrated load P be 60 pounds and be placed at 6 feet from the end. Then, the moment under the load is $-138 \times 3 = -414$ pound-feet, and that at the wall is $-230 \times 5 - 60 \times 4 = -1390$ pound-feet.

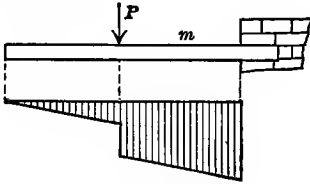
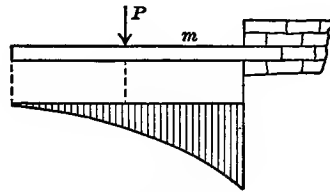
Fig. 38*a*Fig. 38*b*

The algebraic sum of the moments of all the external forces on the left of any section in a beam is called the 'Bending Moment' for that section. These external forces consist of upward reactions and downward loads, and hence the moment of any reaction is positive and that of any load is negative. Let the bending moment be designated by M ; then for any section,

$$M = \text{sum of moments of reactions minus sum of moments of loads}$$

and the bending moment may be positive or negative according as the first or second term is the greater. For the cantilever beam, illustrated above, there is no reaction at the left end, and hence all the bending moments are negative.

For a simple beam of length l , uniformly loaded with w per linear unit, each reaction is $\frac{1}{2}wl$. For any section distant x from the left support, the bending moment is $M = \frac{1}{2}wl \cdot x - wx \cdot \frac{1}{2}x$, x being the lever arm of the reaction $\frac{1}{2}wl$, and $\frac{1}{2}x$ the lever arm of the load wx . Here $M = 0$ when $x = 0$ and also when $x = l$, and M has its greatest value $\frac{1}{8}wl^2$ when $x = \frac{1}{2}l$. The equation is that of a parabola whose graphical representation is as given in Fig. 38*d*, each ordinate showing the value of M for the corresponding value of the abscissa x . Consider next a simple beam loaded with only the three weights P_1, P_2, P_3 . Here $M = R_1x$ for any sec-

tion between the left support and the first load, and $M = R_1x - P_1(x - p_1)$ for any section between the first and second loads. Each of these expressions is the equation of a straight line, x being the abscissa and M the ordinate, and the graphical representation of bending moments is as shown in Fig. 38c. It is seen that for a simple beam all the bending moments are positive.

For any given case, the bending moment at any section may be found by using the above definition. The external forces on the left of the section are taken merely for convenience, for those upon the right of the section produce the same bending moment with reference to the section. The bending moment in all cases is a measure of the tendency of the external forces on either side of the section to turn around a point in that section. If this bending moment is sufficiently large, the internal stresses in the beam become so great that rupture occurs.

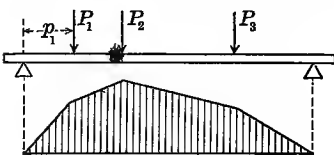

Fig. 38c

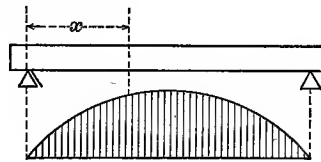

Fig. 38d

The bending moment at any section may also be obtained by using the forces on the right of that section. Thus, for the beam in Fig. 38c, let R_2 be the right reaction and p_3 the distance of the load P_3 from the right support; then for a section under the load P_3 the bending moment is $M = R_2p_3$ and this is equal to that found by using the forces on the left of the section. When forces on the right of a section are used, a moment is to be taken as positive when it tends to cause rotation in the opposite direction to that of the hands of a clock, for this direction would be clockwise if the beam be viewed from the other side.

Prob. 38. Draw a beam resting on three supports and having two spans each 13 feet long. Let a load of 160 pounds be placed at the middle of each span producing a reaction of 220 pounds at the middle support and 50 pounds at each end support. Compute the vertical

shears and bending moments for several sections, and draw diagrams to show their variation throughout the beam.

ART. 39. INTERNAL STRESSES AND EXTERNAL FORCES

The external loads and reactions on a beam maintain their equilibrium by means of internal stresses which are generated in it. It is required to determine the relations between the external forces and the internal stresses; or, since the effect of the external forces upon any section is represented by the vertical shear (Art. 37) and by the bending moment (Art. 38), the problem is to find the relation between these quantities and the internal stresses in that section.

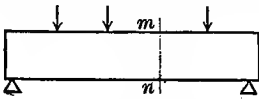

Fig. 39a

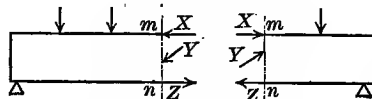

Fig. 39b

Consider a beam of any kind which is loaded in any manner. Imagine a vertical plane cutting the beam at any section mn , as in Fig. 39a. In that section there are acting unknown stresses of various intensities and directions. Let the beam be imagined to be separated into two parts by the cutting plane and let forces X , Y , Z , etc., equivalent to the internal stresses, be applied to the section as shown in Fig. 39b. Then the equilibrium of each part of the beam will be undisturbed, for each part will be acted upon by a system of forces in equilibrium. Hence the following fundamental principle is established.

The internal stresses in any cross-section of a beam hold in equilibrium the external forces on each side of that section.

This is the most important principle in the theory of flexure. It applies to all beams, whether the cross-section be uniform or variable and whatever be the number of the spans or the nature of the loading.

In the above figure the internal stresses X , Y , Z , etc., hold in equilibrium the loads and reactions on the left of the section, and also those on the right. Considering one part only, a system of forces in equilibrium is seen, to which the three necessary

and sufficient conditions of statics for forces in one plane apply (Elements of Mechanics, Art. 5), namely,

- Algebraic sum of all horizontal components= 0
- Algebraic sum of all vertical components= 0
- Algebraic sum of moments of all forces= 0

From these conditions can be deduced three laws concerning the unknown stresses in any section. Whatever be the intensity and direction of these stresses, let each be resolved into its horizontal and vertical components. The horizontal components will be applied at different points in the cross-section, some acting in one direction and some in the other, or in other words, some of the horizontal stresses are tensile and some compressive; by the first condition the algebraic sum of these is zero. The vertical components will add together and form a resultant vertical force V which, by the second condition, equals the algebraic sum of the external forces on the left of the section. Since this internal force V acts in contrary directions upon the two parts into which the beam is supposed to be separated, it is of the nature of a shear. Hence for any section of any beam the following laws concerning the internal stresses may be stated.

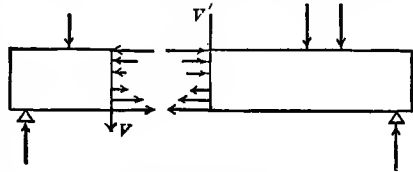

Fig. 39c

1. The algebraic sum of the horizontal stresses is zero; or the sum of the horizontal tensile stresses is equal to the sum of the horizontal compressive stresses.

2. The algebraic sum of the vertical stresses forms a resultant shear which is equal to the algebraic sum of the external vertical forces on either side of the section.

3. The algebraic sum of the moments of the internal stresses is equal to the algebraic sum of the moments of the external forces on either side of the section.

1. The algebraic sum of the horizontal stresses is zero; or the sum of the horizontal tensile stresses is equal to the sum of the horizontal compressive stresses.
2. The algebraic sum of the vertical stresses forms a resultant shear which is equal to the algebraic sum of the external vertical forces on either side of the section.
3. The algebraic sum of the moments of the internal stresses is equal to the algebraic sum of the moments of the external forces on either side of the section.

These three theoretical laws are the foundation of the theory of the flexure of beams; they may be expressed in simpler form by the help of the following definitions.

'Resisting shear' is the name given to the algebraic sum of the internal vertical stresses in any section, and 'vertical shear' is the name for the algebraic sum of the external vertical forces on the left of the section. 'Resisting moment' is the name given to the algebraic sum of the moments of the internal horizontal stresses with reference to a point in the section, and 'bending moment' is the name for the algebraic sum of the moments of the external forces on either side of the section with reference to the same point. Then the three laws may be thus expressed for any section of any beam:

$$\begin{aligned} \text{Sum of tensile stresses} &= \text{Sum of compressive stresses} \\ \text{Resisting shear} &= \text{Vertical shear} \\ \text{Resisting moment} &= \text{Bending moment} \end{aligned}$$

The second and third of these equations furnish the fundamental laws for investigating beams. They state the relations between the internal stresses in any section and the external forces on either side of that section. For the sake of uniformity the external forces on the left-hand side of the section will generally be used, as was done in Arts. 37 and 38.

Prob. 39. A beam 6 feet long is sustained at one end by a force of 280 pounds acting at an angle of 60 degrees with the vertical, and at the other end by a vertical force Y and a horizontal force X . Find the values of X and Y , and the weight of the beam.

ART. 40. NEUTRAL SURFACE AND AXIS

From the three necessary conditions of static equilibrium, as stated in Art. 39, three important theoretical laws regarding internal stresses were deduced. These alone, however, are not sufficient for the full investigation of the subject, but recourse must be had to experience and experiment. Experience teaches that when a beam deflects, one side becomes concave and the other convex, and it is reasonable to suppose that the horizontal tensile stresses are on the convex side and the compressive stresses on the concave side. By experiments on beams this is confirmed, and it is also found that any two parallel vertical straight lines drawn on the beam before flexure remain straight after flexure,

but are nearer together than before on the compressive side and farther apart on the tensile side. Accordingly the following experimental laws may be stated:

4. The horizontal fibers on the convex side are elongated and those on the concave side are shortened, while near the center there is a 'neutral surface' which is unchanged in length.

5. The elongation or shortening of any fiber is directly proportional to its distance from the neutral surface.

Now when the elastic limit of the material is not exceeded, the stresses in the fibers are proportional to their changes in length (Art. 2); therefore,

6. The horizontal stresses are directly proportional to their distances from the neutral surface, provided all unit-stresses are less than the elastic limit of the material.

From these laws there will now be deduced the following important theorem regarding the position of the neutral surface:

The neutral surface passes through the centers of gravity of the cross-sections.

To prove this let δa be the area of any elementary fiber and z its distance from the neutral surface. Let S be the unit-stress on the horizontal fiber most remote from the neutral surface at the distance c . Then by the sixth law,

$$S/c = \text{unit-stress at the distance unity,}$$

$$S \cdot z/c = \text{unit-stress at the distance } z.$$

The total horizontal stress on the fiber at the distance z now is $\delta a \cdot Sz/c$, and hence for the entire cross-section,

$$\Sigma \delta a \cdot Sz/c = (S/c) \Sigma \delta a \cdot z = \text{algebraic sum of all horizontal stresses.}$$

But by the first law of Art. 39 this algebraic sum is zero, and hence the quantity $\Sigma \delta a \cdot z$ must be zero. This, however, is the condition which makes the line of reference pass through the center of gravity, as is plain from the definition of the term 'center of gravity' (Elements of Mechanics, Art. 13). Therefore the neutral surface of a beam passes through the centers of gravity of the cross-sections.

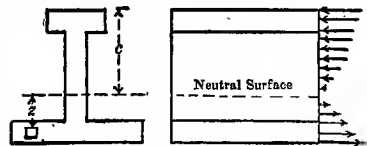

Fig. 40

The 'neutral axis' of a cross-section is the line in which the neutral surface intersects the plane of the cross-section. On the left of Fig. 40 is shown the neutral axis of a cross-section and on the right a trace of the neutral surface.

When a beam is loaded so heavily that the horizontal unit-stress in any fiber exceeds the elastic limit of the material, the neutral surface no longer passes through the centers of gravity of the cross-sections since the fifth law is no longer correct. The common theory of flexure, developed in this and the following chapters, applies therefore only to cases in which the unit-stresses are less than the elastic limit.

Let S be the unit-stress on the horizontal fiber at the most remote distance c from the neutral surface and S_1 be the unit-stress on a fiber at the distance c_1 . Then the sixth law gives,

$$S_1/S = c_1/c \quad \text{or} \quad S_1/c_1 = S/c \quad (40)$$

For example in the beam of Fig. 40 let the depth be 9 inches and the neutral surface be $3\frac{1}{2}$ inches from the base; let the horizontal unit-stress at the upper surface be 4 200 pounds per square inch; then the horizontal unit-stress at the lower surface is $S_1 = S \cdot c_1/c = 4\ 200 \times 3.5/5.5 = 2\ 670$ pounds per square inch. S_1 is tension when S is compression, and S_1 is compression when S is tension, for the stresses on opposite sides of the neutral surface must be of different kinds since their algebraic sum is zero.

The sum of all the horizontal stresses above or below the neutral axis is $(S/c)\Sigma\delta a \cdot z$, in which $\Sigma\delta a \cdot z$ is equal to the moment of the area of the cross-section above or below the neutral axis with respect to that axis. Thus, for a beam 4 inches wide and 6 inches deep the section area above the neutral axis is $4 \times 3 = 12$ square inches, and its center of gravity is $1\frac{1}{2}$ inches from that axis, so that the value of $\Sigma\delta a \cdot z$ is $12 \times 1\frac{1}{2} = 18$ inches³; if S for this case is 600 pounds per square inch, the sum of all the stresses above the neutral axis is $(600/3) \times 18 = 3\ 600$ pounds. This result may also be obtained in another way: the section area above the neutral axis is 12 square inches and the mean unit-stress upon it is 300 pounds per square inch; hence the total stress is $12 \times 300 = 3\ 600$ pounds.

Prob. 40. Let Fig. 40 represent the section of a cast-iron beam in which c is 5 inches, the thickness of the web $1\frac{1}{2}$ inches, the width of the upper flange 3 inches, and its depth 2 inches. If the horizontal unit-stress on the upper fiber is 6 700 pounds per square inch, compute the total horizontal stress above the neutral axis.

ART. 41. SHEAR AND FLEXURE FORMULAS

Consider again any beam loaded in any manner and cut at any section by a vertical plane. The internal stresses in that section hold in equilibrium the external reactions and loads on the left of the section, and as shown in Art. 39, the following fundamental equations apply to that section:

$$\begin{aligned}\text{Resisting shear} &= \text{Vertical shear} \\ \text{Resisting moment} &= \text{Bending moment}\end{aligned}$$

The principles established in the preceding pages can now be applied to the algebraic expression of these four quantities.

The resisting shear is the algebraic sum of all the vertical components of the internal stresses at any section of the beam. If a is the area of that section and S_s the shearing unit-stress, regarded as uniform over the section area, then from Art. 6,

$$\text{Resisting shear} = aS_s$$

The vertical shear for the same section of the beam being V (Art. 37), the first of the above equations becomes,

$$S_s a = V \quad \text{or} \quad S_s = V/a$$

which is the fundamental formula for the discussion of shearing stresses in beams; this will hereafter generally be called the 'shear formula', and it assumes that the shear is uniformly distributed over the section area.

The resisting moment is the algebraic sum of the moments of the internal horizontal stresses in any section with reference to a point in that section. To find an expression for its value let S be the horizontal unit-stress, tensile or compressive as the case may be, upon the fiber most remote from the neutral axis, and let c be the shortest distance from that fiber to said axis. Also let z be the distance from the neutral axis to any fiber having the elementary area δa . Then by Art. 40,

$$\begin{aligned} S/c &= \text{unit-stress at distance unity} \\ S \cdot z/c &= \text{unit-stress at distance } z \\ \delta a \cdot Sz/c &= \text{stress on fiber of area } \delta a \end{aligned}$$

The moment of this fiber stress with respect to the neutral axis of the cross-section is $\delta a \cdot Sz^2/c$, and the algebraic sum of all the elementary moments is the resisting moment, or

$$(S/c)\Sigma\delta a \cdot z^2 = \text{resisting moment of horizontal stresses}$$

But the quantity $\Sigma\delta a \cdot z^2$, being the sum of the products formed by multiplying each elementary area by the square of its distance from the neutral axis, is the 'moment of inertia' of the area of the cross-section with reference to that axis. Let this moment of inertia be represented by I ; then,

$$\text{Resisting moment} = (S/c)I = S \cdot I/c$$

The bending moment for the same section of the beam being M (Art. 38), the second of the above equations becomes,

$$S \cdot I/c = M \quad \text{or} \quad S = M \cdot c/I \quad (41)$$

which is the fundamental formula for the discussion of the horizontal tensile and compressive stresses in beams; this will hereafter generally be called the 'flexure formula'.

Experience and experiment teach that simple beams of uniform section break near the middle by the tearing or crushing of the fibers and rarely at the supports by shearing. Hence it is the flexure formula that is mostly employed in the practical investigation of beams, although for short beams the shear formula must also be used. When the beam is not of uniform section, as is the case in plate girders, the two formulas are of equal importance.

When a beam of given size and shape is to be discussed, its dimensions furnish the value of the section area a , the moment of inertia I , and the distance c from the neutral axis of the section to the side of the beam furthest from that axis. The quantity I/c hence depends only on the dimensions of the cross-section and not at all upon the loads or the material of the beam; for this reason it is called the 'section factor.' There is a certain analogy, then, between the two fundamental formulas for beams; from the first the value of V/S_s must equal the

section area a , from the second the value of M/S must equal the section factor I/c .

To determine the shearing unit-stress in a given section of a beam due to given loads, the vertical shear V is computed by Art. 37 and the section area a by the rules of geometry; then the shear formula gives $S_s = V/a$. To determine the greatest unit-stress of tension or compression in the given section, the bending moment M is computed by Art. 38, and the quantities c and I by the methods of Arts. 42 and 43; then the flexure formula gives $S = M \cdot c/I$. Many applications of these formulas to various kinds of beams will be found in the following chapters.

Prob. 41. A simple beam has a section area of 20 square inches and a span of 15 feet. Over it roll two locomotive wheels 6 feet apart and each bringing 12 000 pounds upon the beam. Find the position of these wheels so as to give the greatest vertical shear at a section close to one of the supports. Compute the mean shearing unit-stress in that section.

ART. 42. CENTERS OF GRAVITY

In the flexure formula $S \cdot I/c = M$, the quantity c is the shortest distance from the remotest part of the cross-section to a horizontal axis passing through the center of gravity of that section. Whenever a cross-section is symmetric with respect to this axis, as in all the cases of Fig. 42a, the center of gravity is evidently at the middle of the depth; thus, if d is the depth of the section, the value of c is $\frac{1}{2}d$.

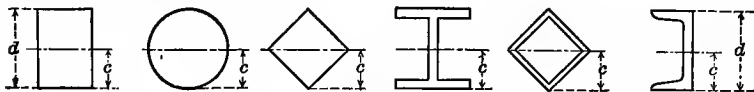

Fig. 42a

For unsymmetric sections the value of c is to be computed from the definition of the center of gravity, using the principle of moments (Elements of Mechanics, Art. 15). For example, take the T section shown in Fig. 42b, the depth being d , the width of the top flange b , the thickness of that flange t_1 , and the thickness of the web t ; the area of the section is $a = td + t_1(b - t)$.

Taking an axis of moments at the foot of the web, the equation of moments is

$$ac = td \times \frac{1}{2}d + t_1(b-t)(d - \frac{1}{2}t_1)$$

from which c is known. For example, let $b = 5$, $t = \frac{1}{2}$, $t_1 = \frac{1}{2}$ and $d = 4$ inches; then $a = 4.25$ square inches, and $c = 2.93$ inches. The same formula holds for the section in Fig. 42c. For the sections in Figs. 42d and 42e, let d be the depth, b_1 and t_1 the width and thickness of the larger flange, b_2 and t_2 the width and thickness of the smaller flange, and t the thickness of the web; then the area of the section is $a = td + t_1(b_1 - t) + t_2(b_2 - t)$, and the equation of moments with respect to the bottom of the lower flange is,

$$ac = td \times \frac{1}{2}d + t_1(b_1 - t)(d - \frac{1}{2}t_1) + t_2(b_2 - t) \times \frac{1}{2}t_2$$

from which c is computed. Actual sections of these forms have the corners more or less rounded, but values of c computed in this manner are usually sufficiently precise for all practical uses.

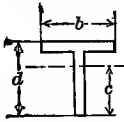

Fig. 42b

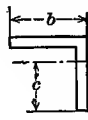

Fig. 42c

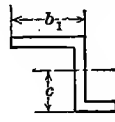

Fig. 42d

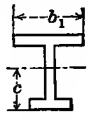

Fig. 42e

The student should be prepared to readily apply the principle of moments to the deduction of the numerical value of c for any given cross-section. In nearly all cases the given area may be divided into rectangles, triangles, and circular sectors, the centers of gravity of which are known, so that the equation for finding c is readily written from the definition of the center of gravity. Triangular beams are never used in practice, but it is well to note that the center of gravity of a triangle lies upon a line parallel to its base and at a distance from that base equal to one-third of the altitude.

Centers of gravity for sections like those of railroad rails are determined by dividing the area into strips which are so small that each may be regarded as a trapezoid. The areas of

these elementary trapezoids being computed, their centers of gravity may be taken at the middle of their widths with sufficient precision, and then the value of c is determined by the same method as that explained above. There is also a graphical method for locating the center of gravity of sections which is sometimes advantageous, and this is set forth in *Roofs and Bridges*, Part II, Art. 12.

Prob. 42a. If the side of a square is d , show that $c = d\sqrt{\frac{1}{2}}$ when the square is placed so that one diagonal is vertical.

Prob. 42b. For a trapezoidal section of depth d , let the shorter base be b' and the longer base be b . Find the distance of the center of gravity from the shorter base.

Prob. 42c. A deck beam has a section like Fig. 42e, except that the lower flange is approximately circular. Find the value of c when the total depth is 10 inches, the width of the upper flange 5 inches, the thickness of that flange $\frac{1}{2}$ inch, the thickness of the web $\frac{3}{8}$ inch, and the diameter of the circular bulb $1\frac{3}{4}$ inches.

ART. 43. MOMENTS OF INERTIA

In the flexure formula $S \cdot I/c = M$, the letter I denotes the moment of inertia of the cross-section of the beam with reference to a horizontal axis passing through the center of gravity of that section. Let δa be any elementary area of the section and z its distance from this axis; then $I = \Sigma \delta a \cdot z^2$ is the equation from which the value of I is ascertained, and this in general is most advantageously done by the methods of the calculus. Strictly speaking an area has no weight or inertia and therefore no moment of inertia, but it is customary to give the name 'moment of inertia' to the quantity $\Sigma \delta a \cdot z^2$, which is of very frequent occurrence in all branches of applied mechanics.

For the rectangle of breadth b and depth d in Fig. 43a, the elementary area δa may be taken as a strip of length b and width δz , or $\delta a = b \cdot \delta z$. Then $\Sigma \delta a \cdot z^2$ equals $\int bz^2 dz$ and the value of z in this integral is to extend between the limits $+\frac{1}{2}d$ and $-\frac{1}{2}d$. This gives $I = \frac{1}{12}bd^3$, which is the moment of inertia of the rect-

angle with respect to an axis through its center of gravity and parallel to the base.

For the triangle with base b and altitude d in Fig. 43*b*, the elementary strip has the width δz and the variable length x . Since the center of gravity is at a distance of $\frac{1}{3}d$ from the base, the value of x is, from similar triangles, $x = (\frac{2}{3}d - z)b/d$, and the expression $\Sigma \delta a \cdot z^2$ becomes $b/d \cdot \int (\frac{2}{3}d - z)z^2 dz$. This being taken between the limits $+\frac{2}{3}d$ and $-\frac{1}{3}d$, gives the result $I = \frac{1}{36}bd^3$, which is the moment of inertia of the triangle with respect to an axis through its center of gravity and parallel to the base b .

For the circle of diameter d in Fig. 43*c*, a similar method may be used. The length of the elementary strip being $2x$, the relation between x and z is given by $x^2 + z^2 = (\frac{1}{2}d)^2$. The general expression $\Sigma \delta a \cdot z^2$ becomes $\int 2xz^2 dz$, and, replacing x by its value in terms of z , and integrating between the limits $+\frac{1}{2}d$ and $-\frac{1}{2}d$, gives the result $I = \frac{1}{64}\pi d^4$, which is the moment of inertia of the area of a circle with respect to an axis through its center.

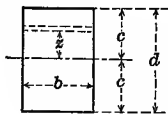
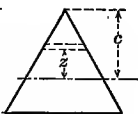
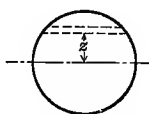
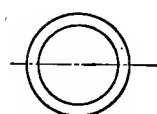
Fig. 43*a*Fig. 43*b*Fig. 43*c*Fig. 43*d*

For the circular annulus in Fig. 43*d*, let d be the outer and d_1 the inner diameter, then it is plain from the definition that the moment of inertia of the annulus is that of the outer circle diminished by that of the inner circle or $I = \frac{1}{64}\pi(d^4 - d_1^4)$. Similarly for the hollow rectangle in Fig. 43*e*, let b and b_1 be the widths and d and d_1 the depths, the thickness of both top and bottom being $\frac{1}{2}(d - d_1)$; then $I = \frac{1}{12}(bd^3 - b_1d_1^3)$. For the I section in Fig. 43*f* where the thickness of each flange is t_1 and that of the web is t , the moment of inertia I is also $\frac{1}{12}(bd^3 - b_1d_1^3)$ if b_1 represents $b - t$ and d_1 represents $d - 2t_1$.

The moment of inertia of a rectangle with respect to an axis through its base is frequently needed. Fig. 43*g* shows this case,

and δa is $b \cdot \delta z$; then $\int bz^2 dz$ is to be taken between the limits d and 0 , which gives $I_1 = \frac{1}{3}bd^3$. This is seen to be four times as great as the moment of inertia for a parallel axis through the center of gravity.

By using the result of the last paragraph, the moment of inertia of the T section in Fig. 43*h* with respect to an axis through its center of gravity can easily be written. Let the distance c and c_1 be first found by Art. 42; let t_1 be the thickness of the flange and t that of the web. Then $\frac{1}{3}tc^3$ is the moment of inertia of the portion of the section below the axis, and $\frac{1}{3}bc_1^3 - \frac{1}{3}(b-t)(c_1-t_1)^3$ is the moment of inertia of the portion above the axis. The sum of these is the required moment of inertia of the entire section.

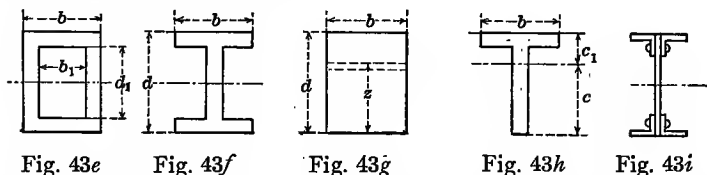

The moment of inertia of any section area is less for an axis through its center of gravity than for any parallel axis. If I is the value for the axis through the center of gravity, I_1 that for any parallel axis, a the area of the section, and h the distance between the two axes, the formula $I = I_1 - ah^2$ furnishes the means of finding I when I_1 is known. For example, take the rectangle of breadth b and depth d where I_1 is known to be $\frac{1}{3}bd^3$ for an axis passing through one of the bases; then for a parallel axis through the center of gravity of the rectangle, the value of I is $\frac{1}{3}bd^3 - bd(\frac{1}{2}d)^2 = \frac{1}{12}bd^3$. Similarly, the value of I_1 for the T section in Fig. 42*b* or Fig. 43*h* with respect to an axis through the base of the web is $\frac{1}{3}bd^3 - \frac{1}{3}(b-t)(d-t_1)^3$, where d is the total depth; this being computed, the value of I for the parallel axis through the center of gravity is $I_1 - ac^2$.

For the beam of Fig. 43*i*, which is made by riveting four angles to a web, the expression of I is the same as that for Fig. 43*f*. It is, however, customary to use tables in finding the numerical value of I for such a section, these tables giving the moments

of inertia of various sizes of angles with respect to axes through their centers of gravity and parallel to the legs. For example, let the horizontal leg of each angle in Fig. 43*i* be 4 inches, the vertical leg 3 inches, and the mean thickness $\frac{1}{2}$ inch. Then Table 10 shows that the distance from the back of the long leg to an axis through the center of gravity of the angle is 0.83 inches, that its section area is 3.25 square inches and that the moment of inertia of the section with respect to this axis is 2.42 inches⁴. Four of these angles being used with a web $\frac{3}{8}$ inches thick and 30 inches depth, the moment of inertia of the angle sections with respect to the horizontal axis through the center of gravity of the web is $4 \times 2.42 + 4 \times 3.25(15 - 0.83)^2 = 2620.0$ inches⁴, while the moment of inertia of the web itself is $\frac{1}{12} \times \frac{3}{8} \times 30^3 = 843.7$ inches⁴, thus giving $I = 2620.0 + 843.7 = 3464$ inches⁴ for the moment of inertia of the entire section with respect to an axis through its center of gravity.

The moment of inertia of a plane area contains the product of four linear dimensions and is hence expressed in quadratic units; for the sake of clearness 'inches⁴' will be used to designate the unit in which I is measured. When lengths are expressed in inches, areas are in square inches, volumes in cubic inches, and moments of inertia in inches⁴. The section factor I/c is the product of three linear dimensions and is expressed in 'inches³'; since it is not a volume the term cubic inches would not be appropriate.

Prob. 43*a*. Consult a book on theoretic mechanics and obtain a proof of the valuable rule $I_1 = I + ah^2$.

Prob. 43*b*. For Fig. 43*h* let the upper flange be $4 \times \frac{1}{2}$ inches, the web be $5\frac{1}{2} \times \frac{1}{2}$ inches, and the total depth be 6 inches. Compute the area of the section and the value of c , without using algebraic formulas. Compute the moments of inertia of flange and web with respect to horizontal axes through their centers of gravity. Transfer these to the horizontal axis shown in the figure and find I for the entire section with respect to that axis.

ART. 44. ROLLED BEAMS AND SHAPES

Soon after 1830, owing to the rapid progress of railroad construction, wrought iron began to come into use for railroad rails

and bridges, and by 1850 rolled beams and angles were extensively employed. The Bessemer and the open-hearth processes of making steel, introduced in 1856 and 1863, rendered it possible to produce ingots from which steel rails and beams could be rolled, but it was not until about 1890 that steel beams began seriously to compete with those of wrought iron. After this date, however, the use of wrought iron for beams and shapes rapidly declined and since 1900 medium steel has taken its place as a structural material (Art. 25).

Table 6, at the end of this volume, gives the properties of the most common sizes of the medium-steel I beams rolled in the United States of America in 1905. The first column contains all the depths that are rolled, but for each depth other sizes than those given in the second, third, and fourth columns may be obtained; for instance, for the 18-inch beam, sizes may be ordered which weigh 65 and 60 pounds per linear foot, the width of the flanges being intermediate between 6.26 and 6.00 inches. The sizes marked with an asterisk are called standard, and they are always found in the market, while the other sizes must generally be specially ordered and hence cost a little more per pound. The fifth column of the table contains the moments of inertia of the sections with respect to an axis AB drawn through the center of gravity of the section and normal to the web, as shown in Fig. 44a; the sixth column contains the section factor I/c , which is obtained by dividing I by one-half of the depth; the seventh column will be explained below. The remaining columns refer to an axis CD through the center of gravity of the section, and are for use in designing columns (Art. 77). Table 13 gives the same quantities for the standard I sections used in Germany, the weights being in kilograms per meter of length and the linear dimensions in centimeters.

By the help of Tables 6 and 13 the flexure formula (41) is readily applied to the discussion of I beams. For example, let a simple span 30 feet long consist of a 10-inch I beam weighing 25 pounds per linear foot, and let it carry a uniform load of 175 pounds per linear foot. The total uniform load then is $w = 200$ pounds per linear foot, and by Art. 38 the maximum

bending moment is $M = \frac{1}{8}wl^2 = 22\ 500$ pound-feet = 270 000 pound-inches. The horizontal unit-stress on the upper or lower side of the beam at the middle of the span is now found from the flexure formula to be $S = M/(I/c) = 111\ 020$ pounds per square inch, this being tension on the lower side and compression on the upper side.

Table 7 contains similar quantities for sections of bulb or deck beams like that shown in Fig. 44*b*, the fifth column giving the distances from the base of the flange to an axis *AB* through the center of gravity and normal to the web; this distance subtracted from the depth of the beam gives the value of *c*, the distance from the neutral axis to the end of the bulb or head. Bulb beams are used only for floors where the beams are visible, but I beams are employed in all kinds of floors as well as in bridges and many other engineering constructions.

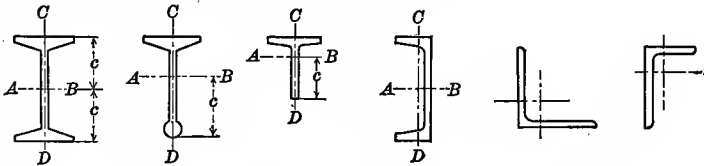

Fig. 44*a* Fig. 44*b* Fig. 44*c* Fig. 44*d* Fig. 44*e* Fig. 44*f*

Beams formed by riveting together plates and channels, or plates and angles, are in common use. Tees, channels, angles, and other forms which alone are not used for beams are called 'shapes', and Tables 8, 9, and 10 give elements of T, C, and L sections which are of value in designing such sections. Many other sizes than those given in the tables are found in the market or may be specially ordered, and the handbooks of the manufacturers contain lengthy tables of the elements of such sections. Fig. 44*c* shows a tee which is occasionally used as a beam, Fig. 44*d* the channel section, Fig. 44*e* an angle section with legs of equal length, and Fig. 44*f* an angle section with unequal legs. For channels and angles the center of gravity usually falls without the section as seen in the figures; through this point rectangular axes are drawn as shown, and the tables give the moment of inertia with respect to each of these axes.

By the help of Table 9 the moment of inertia of the section of the compound beam shown in Fig. 44g can be readily computed. For example, let each channel be 10 inches deep and weigh 15 pounds per linear foot; then from the table the moment of inertia of the two channels with respect to the neutral axis is $2 \times 66.9 = 133.8$ inches⁴. Let each plate be 9×1 inches in section; then by Art. 43 the moment of inertia of each with respect to a horizontal axis through its center of gravity is $\frac{1}{12} \times 9 \times 1^3 = 0.75$ inches⁴, and the moment of inertia of the two plates with respect to the neutral axis of the beam is $2 \times 0.75 + 2 \times 9.00 \times 5.5^2 = 546.0$ inches⁴. Accordingly the required moment of inertia of the section is $I = 133.8 + 546.0 = 679.8$ inches⁴, and the section factor is $I/c = 679.8/6.0 = 113.3$ inches³.

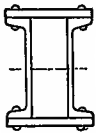

Fig. 44g

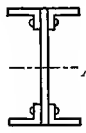

Fig. 44h

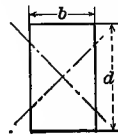

Fig. 44i

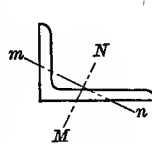

Fig. 44j

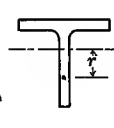

Fig. 44k

The complete theory of moment of inertia is a lengthy one and cannot be properly given in this book, it being a topic of pure mathematics. It should be noted, however, that the sum of the moments of inertia of a plane area with respect to two rectangular axes through a given point is always a constant whatever be the directions of those axes. Thus, for the rectangle in Fig. 44i, the moment of inertia with respect to a horizontal axis through the center of gravity by Art. 43, is $\frac{1}{12}bd^3$ and that for a vertical axis through the same point is $\frac{1}{12}db^3$. If any other rectangular axes be drawn, as in the figure, the moments of inertia with respect to them are less than $\frac{1}{12}bd^3$ and greater than $\frac{1}{12}db^3$, but their sum is equal to $\frac{1}{12}bd(d^2 + b^2)$. In this case the greatest moment of inertia for an axis through the center of gravity is when the axis is parallel to the short side of the rectangle, and the least is when the axis is parallel to the long side. Similarly the moments of inertia for the channel sections in Table 9 are the greatest and least with respect to axes through the center of gravity which are perpendicular and parallel to the web.

For the angle sections in Table 10 the given moments of inertia are with respect to axes through the center of gravity and parallel to the legs, as shown in Figs. 44*e* and 44*f*. These are the values usually required in designing, but it may be mentioned that they are not the greatest and least values. Fig. 44*j* shows the approximate position of the two rectangular axes for which the moments of inertia are greatest and least, MN giving the greatest value and mn the least. When the legs of the angles are equal, each of these axes is inclined to the back of the legs at an angle of 45 degrees.

The center of gyration of a section is the point where the entire area might be concentrated and have the same moment of inertia as the actual distributed area. The distance from the axis to this center is called the 'radius of gyration' and this is designated by r . From this definition it follows that $I = ar^2$, or $r^2 = I/a$. Values of the radius of gyration for rolled steel sections with respect to axes through their centers of gravity are given in Tables 6-10. Fig. 44*k* indicates that the distance r is always less than the distance c from the neutral axis to the remotest fiber.

Prob. 44*a*. Show that the weight of the medium-steel beams and shapes in Tables 6-10 is 3.4 pounds per linear foot for each square inch of cross-section, or 489.6 pounds per cubic foot.

Prob. 44*b*. Let the section in Fig. 44*h* consist of a plate $\frac{3}{4} \times 24$ inches and four angles each $4 \times 3 \times \frac{1}{2}$ inches in size, the longer leg of the angle being horizontal. Compute the moment of inertia of the section with respect to its neutral axis.

ART. 45. ELASTIC DEFLECTIONS

When a beam is subject to the action of loads the horizontal fibers on one side of the neutral axis are elongated and those on the other side are shortened (Art. 40). The beam therefore bends and all points except those over the supports deflect below their original position. The curve assumed by the neutral surface of the beam, when the elastic limit of the material is not exceeded, is called the 'Elastic Curve', and its general equation will now be deduced.

Let mn in Fig. 45a or 45b be any short length measured along the neutral surface of the beam. Let kk' and pp' be two normal sections passing through m and n ; before the bending kk' and pp' were parallel, after the bending they intersect at o , the center of curvature. Let qq' be drawn through n parallel to kk' . Then qp represents the elongation of the fiber kq , and $q'p'$ the shortening of the fiber $k'q'$, and these changes of length are proportional to their distances from the neutral surface. Let the change of length qp be called e and let S be the corresponding unit-stress on the fiber kp , and E be the modulus of elasticity of the material. Let the length of the beam be l and the short distance mn be δl . Then, by Art. 9, the value of qp is $e = (S/E)\delta l$.

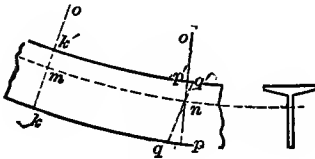

Fig. 45a

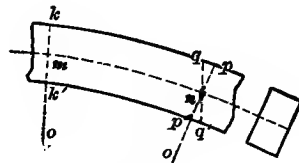

Fig. 45b

Now let c be the distance from qp to the neutral surface of the beam, and let R be the radius of curvature of the elastic curve. From the similar figures omn and pnq , it follows that

$$om/mn = nq/qp \quad \text{or} \quad R/\delta l = c/e$$

and, inserting for e its value $(S/E)\delta l$, this becomes $S/c = E/R$. But the flexure formula (41) gives $S/c = M/I$, where M is the bending moment of the external forces and I is the moment of inertia of the section area. Accordingly,

$$M_R = EI \quad \text{or} \quad R = EI/M$$

which gives the relation between the radius of curvature of the elastic curve at any section and the bending moment at that section. When there is no bending moment, R is infinity or the curve is a straight line; where M has its greatest value, there R has its least value and the curvature is the sharpest.

Now the radius of curvature of any plane curve for which the abscissa is x , the ordinate y , and the length l , is ascertained

in works on differential calculus to be given by $R = \delta l^3 / \delta x \cdot \delta^2 y$. If this value of R be equated to EI/M , there results a general differential equation of the elastic curve which applies to the flexure of all beams or arches in which the elastic limit of the material is not exceeded. In discussing a beam the axis of x is taken as horizontal and that of y as vertical. Since experience teaches that the length of a small part of a bent beam does not materially differ from that of its horizontal projection, the length δl may be placed equal to δx , and,

$$\frac{\delta^2 y}{\delta x^2} = \frac{M}{EI} \quad \text{or} \quad EI \frac{\delta^2 y}{\delta x^2} = M \quad (45)$$

which is the differential equation for the discussion of the elastic deflection of beams. In this formula y is the ordinate of the elastic curve at the point where the abscissa is x , and the relation between y and x is to be obtained by integrating the differential equation twice and determining the constants of integration; for this purpose M is to be expressed as a function of x . Unless otherwise stated I will be regarded as a constant, that is, the beam is of uniform section throughout its length.

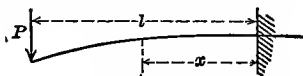

Fig. 45c



Fig. 45d

Numerous applications of this general formula will be given in the following chapters, and only the simple case of a cantilever beam under a load at the end will be here discussed. Let Fig. 45c represent the beam which is horizontal at the wall, l being its length. Let the origin of coordinates be taken at the wall, values of x being positive toward the left and upward values of y positive. The bending moment at any section distant $l-x$ from the left end is $-P(l-x)$, and the differential equation (45) for this case is,

$$EI \frac{\delta^2 y}{\delta x^2} = -Pl + Px$$

Integrating this equation, and determining the constant of integration by the condition that the value of the tangent $\delta y / \delta x$

becomes zero when x equals zero there results,

$$EI \frac{\delta y}{\delta x} = -Plx + \frac{1}{2}Px^2$$

Integrating again and determining the constant by the condition that y equals zero when x is zero, there is found,

$$EIy = -\frac{1}{2}Plx^2 + \frac{1}{6}Px^3$$

which is the equation of the elastic curve. When x equals l the value of y is the deflection of the end, which is $-Pl^3/3EI$.

The equation $M_R = EI$ shows that M and R must always have the same sign, since EI can never be negative. When the bending moment M is positive, R is also positive and it is directed upward as in Fig. 45*a*; when M is negative, R is also negative and it is directed downward as in Fig. 45*b*. A positive bending moment hence indicates that the lower side of the beam is convex or in tension, while a negative bending moment indicates that the lower side of the beam is concave or in compression.

Prob. 45*a*. A straight stick of wood, $2 \times 2 \times 18$ inches, is laid on two supports very near its ends. Compute the radius of curvature of the elastic curve at the middle.

Prob. 45*b*. Prove, when two equal loads on a simple beam are equally distant from the middle, that the elastic curve of the part of the beam between them is a circle.

Prob. 45*c*. Find the equation of the elastic curve for the cantilever beam of Fig. 45*d* under uniform load, taking the origin of coordinates at the free end and letting values of x be positive toward the right.

CHAPTER VI

CANTILEVER AND SIMPLE BEAMS

ART. 46. SHEAR AND MOMENT DIAGRAMS

The fundamental principles relating to beams have been deduced in the preceding chapter and it now only remains to apply them to special cases. The shear formula $S_s \cdot a = V$ and the flexure formula $S \cdot I/c = M$ (Art. 41) contain all the quantities needed for investigation or design, and the first step is to obtain the values of the vertical shear V and the bending moment M ; for brevity these will hereafter be called 'shear' and 'moment'. Arts. 37 and 38 show that V and M vary throughout the beam, and the manner in which they vary will now be further discussed. The maximum values of V and M will give the greatest values of the unit-stresses S_s and S .

The method of computing the shear V and the moment M for any given section of a simple beam is by the use of the definitions of these quantities, namely,

V = Left reaction minus loads on left of section

M = Moment of left reaction minus moment of loads on left

and these apply also to cantilever beams by making the left reaction equal to zero, since there is no reaction at the left end. From these definitions, values of V and M for several sections are readily computed and graphical representations of the results may then be made.

The following figures show shear and moment diagrams for a cantilever beam, Fig. 46*a* being for a uniform load, Fig. 46*b* for a concentrated load at the free end, and Fig. 46*c* for both uniform and concentrated load, the upper diagram being for the shears and the lower one for the moments. To explain the manner of their construction, it will be sufficient to consider only the third case. Let the beam be 15 feet long, the uniform

load be 40 pounds per linear foot and the concentrated load be 700 pounds. The shear at the free end on the right of the concentrated load is $V = -700$ pounds, at 5 feet from the left end it is $V = -700 - 5 \times 40 = -900$ pounds, at 10 feet from the left end it is $V = -700 - 10 \times 40 = -1100$ pounds, and at the wall it is $V = -700 - 15 \times 40 = -1300$ pounds; these values are laid off to scale downwards from a horizontal line and the line connecting their lower ends is then drawn. The moment at the free end is zero, since the lever arm of the concentrated load for this section is zero, the moment at 5 feet from the left end is $M = -700 \times 5 - 200 \times 2\frac{1}{2} = -4000$ pound-feet, at 10 feet from the left end it is $M = -700 \times 10 - 400 \times 5 = -9000$ pound-feet, and at the wall it is $M = -700 \times 15 - 600 \times 7\frac{1}{2} = -15000$ pound-feet; these values are laid off to scale and a line connecting their lower ends is drawn. The diagrams thus constructed shows clearly the distribution of the shears and moments throughout the beam.

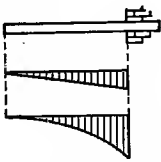

Fig. 46a

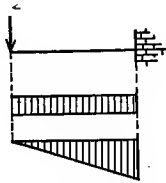

Fig. 46b

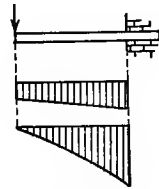

Fig. 46c

The following figures show shear and moment diagrams for a simple beam, Fig. 46d being for uniform load, Fig. 46e for one concentrated load, and Fig. 46f for both uniform and concentrated loads. For the last case let the beam be 18 feet long and weigh 20 pounds per linear foot, the larger load being 360 pounds at 6 feet from the left end and the smaller one being 90 pounds at 12 feet from the left end. The reactions of the left and right supports are found by Art. 36 to be 450 and 360 pounds, the sum of which equals the total load, 810 pounds. To construct the shear diagram a sufficient number of values of V must be computed; thus, at the right of the left support $V = +450$, at the left of the first load $V = +450 - 120 = +330$, at the right of that load $V = +450 - 120 - 360 = -30$, at the middle of the

span $V = +450 - 180 - 360 = -90$ pounds, and so on. To construct the moment diagram several values of M are computed; thus at 3 feet from the left end $M = 450 \times 3 - 60 \times 1\frac{1}{2} = +1260$, under the first load $M = 450 \times 6 - 120 \times 3 = +2340$, at the middle of the span $M = 450 \times 9 - 180 \times 4\frac{1}{2} - 360 \times 3 = +2160$ pound-feet, and so on. These values being laid off as ordinates and lines being drawn connecting their ends, the distribution of the shears and moments throughout the beam is graphically represented.

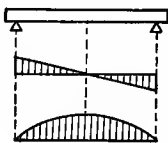

Fig. 46d

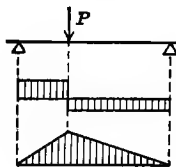

Fig. 46e

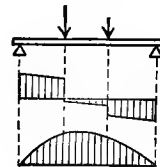

Fig. 46f

From the definitions of V and M and from the general discussions in Arts. 37 and 38, it is seen that the shears are always represented by ordinates to straight lines which are inclined when uniform load is considered and horizontal when concentrated loads are alone considered. It is also seen that the moments are represented by ordinates to straight lines for concentrated loads alone and by ordinates to parabolic curves for uniform load either alone or accompanied by concentrated loads.

The above diagrams for simple beams show that the maximum moment occurs at the section where the shear passes through zero. This is indeed a general law the truth of which will be demonstrated in the next article. This law also applies to cantilever beams, for at the wall there is a reaction equal to the weight of the beam and hence on passing beyond that section the shear becomes zero.

Prob. 46a. Construct shear and moment diagrams for a cantilever beam 10 feet long and weighing 13 pounds per linear foot, there being a concentrated load of 75 pounds at 2 feet from the left end.

Prob. 46b. Construct shear and moment diagrams for a simple beam 20 feet long and weighing 13 pounds per linear foot, there being a concentrated load of 240 pounds at 5 feet from the left end.

ART. 47. MAXIMUM SHEARS AND MOMENTS

The greatest numerical value of the shear or moment which occurs in a beam under a given system of loads is called the maximum value, whether it be positive or negative. These maximum values are to be used in the shear and flexure formulas of Art. 41 without regard to sign, for the signs + and - prefixed to a shear indicate merely whether the left part of the beam tends to slip up or down with respect to the other part (Art. 37), while when prefixed to a moment they indicate merely whether the upper side of the beam is concave or convex (Art. 44).

For a cantilever beam both maximum shear and moment occur at the wall. Let w be the uniform load per linear unit, l the length of the beam, and W the total load wl ; then the maximum shear is $V = -wl = -W$, and the maximum moment is $M = -W \times \frac{1}{2}l = -\frac{1}{2}Wl$. Let P be any concentrated load at the left end of the beam, as in Fig. 46b, then the maximum shear is $V = -P$ and the maximum moment is $M = -Pl$. Or, without regard to sign, the maximums for a cantilever beam are,

For uniform load	$V = W$	$M = \frac{1}{2}Wl$
For P at the end	$V = P$	$M = Pl$

If P is not at the free end but at the distance p from that end, as in Fig. 47a, the maximum shear is also P , but the maximum moment is $P(l-p)$.

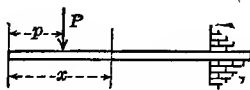

Fig. 47a

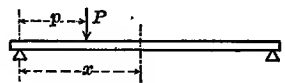

Fig. 47b

For a simple beam under uniform load alone, each reaction is $\frac{1}{2}wl$ and the shear at any section distant x from the left support is $V = +\frac{1}{2}wl - wx$; the maximum shears hence occur when $x = 0$ and $x = l$, their values being $+\frac{1}{2}W$ and $-\frac{1}{2}W$. The moment for the section distant x from the left support is $M = +\frac{1}{2}wl \cdot x - wx \cdot \frac{1}{2}x$, and by the usual method of the differential calculus this is found to be a maximum when $x = \frac{1}{2}l$,

and for this value $M = +\frac{1}{8}wl^2 = \frac{1}{8}Wl$. For a single load P at the middle of a simple beam, each reaction is $\frac{1}{2}P$ and this is the maximum shear; also the moment at any section between the left support and the middle is $M = +\frac{1}{2}Px$, and this is a maximum when $x = \frac{1}{2}l$, as Fig. 46*e* shows. Hence without regard to sign, the maximums for a simple beam are,

For uniform load	$V = \frac{1}{2}W$	$M = \frac{1}{8}Wl$
For P at the middle	$V = \frac{1}{2}P$	$M = \frac{1}{4}Pl$

If P is not at the middle but at the distance p from the left end, as in Fig. 47*b*, the left reaction is $P(l-p)/l$ and the right reaction is Pp/l and these are the maximum shears; the maximum moment is under the load and its value is R_1p or $P(l-p)p/l$, which has its greatest value $\frac{1}{4}Pl$ when p equals $\frac{1}{2}l$.

When one or more concentrated loads are on a simple beam, the maximum shears are the reactions of the supports, and the maximum moment due to these loads occurs under one of the loads, as in Fig. 38*c*. The maximum moment due to both uniform and concentrated loads also often occurs under one of the single loads, as seen in Fig. 46*f*, but it sometimes occurs at a different section, as is the case in Prob. 46*b*. The section where the moment is a maximum is called the 'dangerous section', since there the greatest horizontal stress S will be found by the use of the flexure formula $S \cdot I/c = M$ (Art. 41). In order to locate the dangerous section, the following important law may be used.

The dangerous section is that where the shear passes through zero. To prove this, let there be several loads on a simple beam, P_1 at the distance p_1 and P_2 at the distance p_2 from the left support, and so on. Let R_1 be the left reaction due to these loads and the uniform load wl . Then the bending moment for a section distant x from the left support is,

$$M = R_1x - \frac{1}{2}wx^2 - P_1(x-p_1) - P_2(x-p_2) - \text{etc.}$$

in which only the single loads appear which are between the left support and the section. The value of x which makes the bending moment a maximum is obtained by equating to

zero the derivative of M with respect to x , or

$$\delta M / \delta x = R_1 - wx - P_1 - P_2 - \text{etc.} = 0$$

is the equation which gives the value of x . But $R_1 - wx - P_1 - P_2$ is the shear V for this section, as is clear from the definition of vertical shear in Art. 37. Therefore the maximum moment occurs at the section where the shear passes through zero. This section can readily be found by computing shears for different sections, and the construction of the shear diagram will always be of assistance.

For example take the data of Prob. 46*b* where $l = 20$ feet, $w = 13$ pounds per linear foot, and $P_1 = 240$ pounds at $p_1 = 5$ feet. The left reaction $R_1 = 130 + \frac{3}{4} \times 240 = 310$ pounds. The shear just at the left of P is $+310 - 65 = +245$ and just at the right of P it is $+310 - 65 - 240 = +5$ pounds, and hence V does not pass through zero under the single load. To find the exact position of the dangerous section, let x be its distance from the left support; then the shear is $310 - 13x - 240$ and equating this to zero, there is found $x = 5.385$ feet. The maximum moment is $310 \times 5.385 - \frac{1}{2} \times 13 \times 5.385^2 - 240 \times 0.385 = 1388$ pound-feet.

Prob. 47*a*. Compute the maximum shear and moment for a cantilever beam 13 feet long which weighs 33 pounds per linear foot and has a single load of 375 pounds at 3 feet from the free end.

Prob. 47*b*. A simple beam of 12 feet span weighs 35 pounds per linear foot and has three concentrated loads of 300, 60, and 150 pounds at 3, 5, and 8 feet respectively from the right support. Compute the maximum shear and moment, and draw the shear and moment diagrams.

ART. 48. INVESTIGATION OF BEAMS

The investigation of a beam of constant cross-section usually consists in computing the greatest horizontal unit-stress S from the flexure formula $S \cdot I/c = M$ which was established in Art. 41. For this purpose the formula may be written

$$S = Mc/I \quad \text{or} \quad S = M/(I/c) \quad (48)$$

the first of which may be used when c is determined by Art. 42

and I by Art. 43, and the second when the section factor I/c for rolled beams is taken from tables (Art. 44). The greatest value of S will be found at the dangerous section where M is a maximum and hence the maximum moment is to be ascertained from Art. 47. If M is computed in pound-feet, it must be reduced to pound-inches when I and c are expressed in terms of inches; then the value of S will be in pounds per square inch.

The unit-stress S will be tension or compression according as the remotest fiber from the neutral surface lies on the convex or concave side of the beam, c being the distance between that fiber and the neutral surface. If S' is the unit-stress on the opposite side of the beam and c' the distance from it to the neutral surface, then by Art. 40,

$$S/c = S'/c' \quad \text{or} \quad S' = S \cdot c'/c$$

When S is tension, S' is compression; when S is compression, S' is tension. Sometimes it is necessary to compute S' as well as S in order thoroughly to investigate the stability of the beam. By comparing the values of S and S' with the proper working unit-stresses for the given materials (Art. 7), the degree of security of the beam may be inferred.

As an example consider a cast-iron I beam which has a depth of 10 inches, width of flanges 6 inches, thickness of flanges and web 1 inch. It is supported at its ends forming a span of 12 feet, and carries two loads, each weighing 5 000 pounds, one being at the middle and the other at one foot from the right end. The steps of the computation are as follows:

by geometry,	$a = 20$ square inches
by Art. 42,	$c = 5$ inches
by Art. 43,	$I = 286.7$ inches ⁴
by Art. 17,	$w = 62.7$ pounds per linear foot
by Art. 47,	$x = 6$ feet for dangerous section
by Art. 38,	max. $M = 18\ 630$ pound-feet

Then from the flexure formula, the unit-stress is,

$$S = 18\ 600 \times 12 \times 5 / 287 = 3\ 900 \text{ pounds per square inch}$$

which is the tensile stress on the lower side of the beam and

the compressive stress on the upper side. The factor of safety in compression is $90\,000/3\,900$ or about 23, while that in tension is $20\,000/3\,900$ or about 5; the degree of security for compression is ample, but that for tension is too low (Art. 7).

As a second example, consider a simple wooden beam, 3 inches wide, 4 inches deep, and 16 feet span, and let a man weighing 150 pounds stand at the middle. Here $b=3$ inches, $d=4$ inches, $l=16$ feet = 192 inches, $c=\frac{1}{2}d=2$ inches, $I=\frac{1}{12}bd^3=16$ inches⁴, the weight of the beam $W=10\times 12\times 5\frac{1}{2}/12=53.3$ pounds, and $P=150$ pounds. The dangerous section is at the middle, and the maximum moment due to the uniform and single loads is, from Art. 47, $M=\frac{1}{8}Wl+\frac{1}{4}Pl=706.7$ pound-feet = 8 480 pound-inches. Then the flexure formula gives $S=8\,480\times 2/16=1\,060$ pounds per square inch, which is a satisfactory unit-stress for the tension of timber under a steady load, but is a little too high for compression.

A short beam heavily loaded should also be investigated for shearing at the supports by the shear formula $S_s a = V$ (Art. 41), but for common cases there is ample security against this stress. For the cast-iron beam above discussed, the maximum shear is at the right support and its value is 7 460 pounds; hence $S_s=7\,460/20=373$ pounds per square inch, so that the factor of safety against shearing is about 48. Similarly for the timber beam, the factor of safety against shearing may be found to be greater than 350.

When the load upon a beam is heavy compared with its own weight, the latter may be omitted from the computation as its influence is small. A common rule in practice is that the weight of the beam may be neglected whenever the moment due to it is less than ten percent of that due to the loads on the beam; for a concentrated load at the middle this will be the case when $\frac{1}{8}Wl$ is less than one-tenth of $\frac{1}{4}Pl$, that is, when P is greater than $5W$.

Prob. 48a. A piece of scantling 2 inches square and 10 feet long is hung horizontally by a rope at each end and two students stand upon it. Is it safe?

Prob. 48*b*. A cast-iron bar one inch in diameter and two feet long is supported at its middle and a load of 200 pounds hung upon each end of it. Find its factor of safety.

ART. 49. SAFE LOADS FOR BEAMS

The proper load for a beam should not make the value of S at the dangerous section greater than the allowable unit-stress. This allowable unit-stress or working strength may be assumed according to the circumstances of the case by first selecting a suitable factor of safety from Art. 7 and dividing the ultimate strength of the material by it, the least ultimate strength whether tensile or compressive being taken. For any given beam the quantities I and c are known. Then, in the flexure formula $M = S \cdot I/c$ the maximum moment M may be expressed in terms of the length of the beam and the unknown loads, and thus those loads be found.

As an example, consider a wooden cantilever beam whose length is 6 feet, breadth 2 inches, depth 3 inches, and which is loaded uniformly with w pounds per linear foot. It is required to find the value of w so that S may be 800 pounds per square inch. Here $c = 1\frac{1}{2}$ inches, $I = \frac{54}{12}$, and $M = 36 \times 6w$. Then, from the flexure formula, $216w = 800 \times 54/1\frac{1}{2} \times 12$, whence $w = 11$ pounds per linear foot. Since this wooden beam weighs about 2 pounds per foot, the total safe uniform load will be about $9 \times 6 = 54$ pounds.

As a second example, take a rolled steel I beam of 18 feet span which is 10 inches deep and weighs 25 pounds per foot, and let it be required to find what concentrated load P may be put at the middle in order that the unit-stress at the dangerous section shall be 15 000 pounds per square inch. From Table 6 the value of the section factor I/c is 24.4 inches³. From Art. 47 the maximum moment is $M = \frac{1}{4}P \times 18 \times 12$ pound-inches if the weight of the beam be disregarded. Accordingly $54P = S \cdot I/c$ or $54P = 15\,000 \times 24.4$, whence $P = 6\,780$ pounds. As this is more than five times the weight of the beam, it may be taken as the allowable load (Art. 48). If the weight of the beam is considered,

however, the moment is $M = 54P + 12150$, and placing this equal to $S \cdot I/c$ there is found $P = 6560$ pounds, which is only about three percent less than the value obtained before.

As an example of an unsymmetric section, let it be required to determine the total uniform load W for a cast-iron T beam of 14 feet span, so that the factor of safety may be 6, the depth of the beam being 18 inches, the width of the flange 12 inches, the thickness of the stem 1 inch, and the thickness of the flange $1\frac{1}{4}$ inches. First, from Art. 42 the value of c is found to be 12.63 inches, and that of c' to be 5.37 inches. From Art. 43 the value of I is computed to be 1031 inches⁴. From Art. 47 the maximum moment is $M = \frac{1}{8}Wl = 21W$ pound-inches. Now with a factor of safety of 6, the working unit-stress S on the compressive side of the dangerous section is to be $\frac{1}{6} \times 90000 = 15000$ pounds per square inch; then, inserting the values in the flexure formula $M = SI/c$, the load W is found to be 58300 pounds. Again with a factor of safety of 6, the working unit-stress S' on the tensile side of the dangerous section is to be $\frac{1}{6} \times 20000 = 3330$ pounds per square inch; inserting the values in the flexure formula $M = S'I/c'$, the load W is found to be 30400 pounds. The total uniform load on the beam should hence not exceed 30400 pounds, and under this load the factor of safety on the compressive side is nearly 12.

Prob. 49a. A simple wooden beam, 8 inches wide, 9 inches deep, and 14 feet in span, carries two equal loads, one being 2.5 feet on the left of the middle and the other 2.5 feet on the right. Find these loads so that the factor of safety of the beam shall be 10.

Prob. 49b. A steel railroad rail of 2 feet span carries a load P at the middle. If its weight per yard is 56 pounds, $I = 12.9$ inches⁴ and $c = 2.16$ inches, find P so that the greatest horizontal unit-stress at the dangerous section shall be 6000 pounds per square inch.

ART. 50. DESIGNING OF BEAMS

When a beam is to be designed, the loads to which it is to be subjected are known, as also is its length, and from these the maximum bending moment may be found by Art. 47. The

allowable working unit-stress S is assumed in accordance with engineering practice. Then the flexure formula (41) may be written

$$I/c = M/S \quad (50)$$

and the numerical value of the second member be found. The dimensions to be chosen for the beam must be such that the section factor I/c shall be equal to this numerical value, and these in general are determined by trial, certain proportions being first assumed. The selection of the proper proportions and shapes of beams for different cases requires much judgment and experience; but whatever forms be selected, they must in each case be such as to satisfy the above equation.

For instance, a simple beam of structural steel, 16 feet in span, is required to carry a rolling load of 500 pounds. Here, by Art. 47, the value of maximum M due to the load of 500 pounds is 24 000 pound-inches. From Art. 7 the allowable value of S for a variable load is about 10 000 pounds per square inch; then,

$$I/c = 24\,000/10\,000 = 2.4 \text{ inches}^3$$

An infinite number of cross-sections may be selected having this value of I/c . If the section is round and of diameter d , it is known that $c = \frac{1}{2}d$ and $I = \frac{1}{64}\pi d^4$, hence $\frac{1}{8}\pi d^3 = 2.4$, from which $d = 2.9$ inches. If the section is rectangular, 2 inches wide and $2\frac{3}{4}$ inches deep, I/c is 2.5, which is a little too large, but it would be well to use this size because the weight of the beam itself has not been considered in the discussion. The dimensions finally selected may be investigated by Art. 49 in order to determine how closely the actual unit-stress agrees with the value assumed. Thus, the rectangular section $2 \times 2\frac{1}{2}$ inches weighs 17 pounds per foot; the maximum moment is then 30 800 pound-inches and the unit-stress is found to be 11 800 pounds per square inch, which is 18 percent larger than the allowable value; a larger size than $2 \times 2\frac{1}{2}$ inches is hence required, and 2×3 inches will be found to be larger than necessary.

When the design of a structure involves rolled I beams, the computation of the maximum value of M/S is made as before,

and the corresponding number is sought in that column of Table 6 which is headed I/c . For example, take a floor which is required to carry a uniform load of 180 pounds per square foot including its own weight, this weight being brought upon rolled steel beams which are of 24 feet span and spaced 4 feet apart. It is required to find what size of beam should be used, the allowable unit-stress S being specified as 16 000 pounds per square inch. First, the total uniform load on one beam is found to be $W = 180 \times 24 \times 4 = 17\ 280$ pounds; second, the maximum moment is $M = \frac{1}{8} \times 17\ 280 \times 24 \times 12$ inch-pounds; third, from these $M/S = 38.9$, which is the required value of I/c ; fourth, Table 6 shows that the 12-inch beam weighing 40 pounds per foot has $I/c = 44.8$, and this is the size to be selected. The larger table given in the handbook of the manufacturers indicates, however, that a 12-inch beam weighing 35 pounds per foot may be obtained by special order and that its value of I/c is 38.0; whether this would be cheaper than the 12-inch beam weighing 40 pounds per foot can be determined only by asking quotations of prices.

Prob. 50a. A 100-lb. 15-inch steel I beam of 12 feet span sustains a uniformly distributed load of 41 net tons. Find its factor of safety. Also the factor of safety for a 24-foot span under the same load.

Prob. 50b. A floor, which is to sustain a uniform load of 175 pounds per square foot, is to be supported by heavy 10-inch steel I beams of 15 feet span. Find their proper distance apart from center to center, so that the maximum fiber stress may be 12 000 pounds per square inch.

ART. 51. ECONOMIC SECTIONS

The two fundamental objects to be secured in designing engineering structures are stability and economy (Art. 7). In the case of a beam, proper security will be attained when the horizontal unit-stress S does not exceed that allowable in good practice, and economy will be secured by giving such proportions to the cross-section that S is not less than the allowable value. Both stability and economy will hence usually be promoted by making the beam of such a size that the horizontal

unit-stress S has the given allowable value at the dangerous section when the beam is fully loaded. There is, however, another important idea to be considered, namely, the shape of the section should be such that the weight of the beam shall be as small as possible, and this will be attained by making the section area a as small as possible and yet keep the unit-stress S at the given allowable value.

Since the horizontal unit-stresses in the section increase from the neutral surface to the upper and lower sides of the beam, it is evident that a deep section will in general require less area to furnish a given unit-stress S than a shallow one. Thus, for a rectangular section of breadth b and depth d , the section factor I/c is $\frac{1}{12}bd^3/\frac{1}{2}d$ or $\frac{1}{6}bd^2$, so that the flexure formula becomes $\frac{1}{6}bd^2 = M/S$ or $a = 6M/Sd$, so that for given values of M and S , the section area a will be rendered small by making the depth d large. The depth, however, should not be made so great as to give a thin section, for this would be deficient in lateral stiffness. The proper ratio between b and d is governed by engineering precedent and practice; an extreme limit is perhaps that found in wooden floor joists where the depth is about six times the breadth.

Iron and steel beams may be cast or rolled with almost any desired shape of section. Cast-iron Γ and \mathbf{I} beams came into use early in the nineteenth century; after 1840 wrought-iron rolled beams gradually replaced those of cast-iron for railroad use, and these in turn gave way after 1890 to rolled steel beams. In these forms the sections have such a shape that the section area is the least possible for a given required unit-stress S , and this is accomplished by concentrating most of the material in the flanges and thus having the larger part of the section area as far from the neutral axis as practicable. The flexure formula $SI/c = M$ shows that this practice is correct, for, under a given bending moment M , the unit-stress S will be made small by making I/c as large as possible, and from the definition of the moment of inertia (Art. 43) it is clear that I will be rendered large by placing the material as far as practicable from the neu-

tral axis. The value of I may be expressed by ar^2 , where a is the section area and r is the radius of gyration of the section, that is, the distance from the neutral axis to the point where all the section area might be concentrated and have the same moment of inertia as the actual distributed area. Inserting this for I in the flexure formula, it becomes $ar^2/c = M/S$ and thus it is plain that a may be rendered small by making r^2/c as large as possible. Since r is always less than c , the placing of the greater part of the section in the flanges, while the web is made thin, renders r^2/c much larger than for a rectangular section, and thus a is made smaller and economy of material is secured.

For example, take the smallest 15-inch I beam in Table 6 for which $a = 12.48$ square inches, $I = 441.7$ inches⁴ and $I/c = 58.9$ inches³. A square section of the same strength must have the same value of I/c , whence $\frac{1}{6}d^3 = 58.9$ and $a = 50.0$ square inches, which is four times the section area of the I and hence the square beam will weigh four times as much as the I beam, and its cost will be four times as much if the price per pound is the same.

For wrought iron and structural steel the ultimate strengths in tension and compression and the allowable unit-stresses are usually the same; hence the flanges of beams of these materials are made equal in size. Cast-iron, however, has a much higher ultimate strength in compression than in tension and hence the tensile flange should have the larger area. The proper relative proportions of the flange areas of cast-iron beams have never been definitely established, and such beams are now rarely used except in unimportant buildings.

The strongest rectangular beam that can be cut from a circular log will be that which has the largest section factor I/c . If b be the breadth and d the depth, the section factor is $\frac{1}{6}bd^2$, and bd^2 is to be made a maximum; or, if D be the diameter of the log, $b(D^2 - b^2)$ is to be made a maximum. Differentiating this and equating the derivative to zero, gives,

$$b = D\sqrt{\frac{2}{3}} \quad \text{whence} \quad d = D\sqrt{\frac{2}{3}}$$

Hence b is to d as 5 to 7 nearly. From this it is easy to show that the way to lay off the strongest rectangular beam on the end of a circular log is to divide the diameter into three equal parts, from the points of division draw perpendiculars to the circumference, and then join the points of intersection with the ends of the diameter, as shown in the figure.

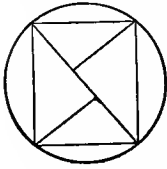



Fig. 51

The rectangular beam thus cut out is, of course, not as strong as the log, and the ratio of its strength, to that of the log is that of their values of I/c , which will be found to be about 0.65.

Prob. 51. Cast-iron beams with a  section are sometimes used in buildings. Let the thickness be uniformly one inch, the base 8 inches, the height 6 inches, and the span 12 feet. Find the unit-stresses S and S' at the dangerous section under a uniform load of 5 000 pounds.

ART. 52. RUPTURE OF BEAMS

The flexure formula $S \cdot I/c = M$ is only true for stresses within the elastic limit of the material, since beyond that limit the latter part of law 6 of Art. 40 does not hold. Experience shows that the elongations and shortenings of the horizontal fibers are proportional to their distances from the neutral axis when the stresses exceed the elastic limit, but these changes of length increase in a more rapid ratio than the unit-stresses (Arts. 4-5). Hence the unit-stresses of tension and compression increase in a less rapid ratio than their distance from the neutral axis for all fibers where the elastic limit is exceeded. Thus Fig. 52a represents a rectangular cast-iron beam where the tensile unit-stresses below n have exceeded the elastic limit, while Fig. 52b shows a T section under similar conditions. Here the algebraic sum of all the horizontal stresses is zero, but the neutral surface does not pass through the center of gravity of the section, because the unit-stresses are not proportional to their distances from that surface as is required in the demonstration of Art. 40.

When a beam is loaded so heavily that any fiber on one or

both sides of the neutral surface are stressed above the elastic limit, the flexure formula $S \cdot I/c = M$ is not valid, and a value of S computed from it is not correct. It is, however, very customary to use this formula for the rupture of beams, but in so doing it must not be forgotten that it is so used merely for convenience of making comparisons and not on account of any theoretical basis.

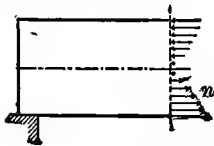

Fig. 52a

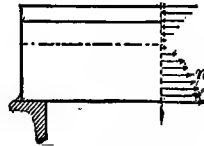

Fig. 52b



When a beam is ruptured under transverse loads the value of S computed from the flexure formula is called the 'ultimate flexural strength' of the material. If this formula were valid beyond the elastic limit, the value of S for rupture would agree with the least ultimate strength of the material, with tension in the case of cast iron and with compression in the case of timber. It is, however, always found that this computed value does not agree with either the ultimate tensile or compressive strength of the material but is intermediate between them. This quantity is not a physical constant, but a figurative value computed from an incorrect formula, and hence is mainly valuable for rough comparative purposes. It will be designated by S_f , and the following are its approximate average values in pounds per square inch as determined by experiment:

Material	Tensile Strength, S_t	Flexural Strength, S_f	Compressive Strength, S_c
Brick		800	3 000
Stone		2 000	6 000
Timber	10 000	9 000	8 000
Cast Iron	20 000	35 000	90 000
Wrought Iron	50 000		50 000
Structural Steel	60 000		60 000
Strong Steel	100 000	110 000	120 000

For wrought iron and structural steel no values of S_f are given

because beams of these materials bend indefinitely under increasing transverse loads, so that failure does not occur by breaking. In fact, bars of wrought iron and soft steel may be bent double without breaking (Arts. 24 and 25).

By the use of the above experimental values of S_f , it is easy, with the help of the formula $S_f \cdot I/c = M$, to determine what load will cause the rupture of a given beam, or what must be its length or size in order that it may rupture under assigned loads. The formula when used in this manner is entirely empirical and has no rational basis. As an example, let it be required to find the length of a cast-iron cantilever beam, 2×2 inches in section, in order that it may break at the fixed end under its own weight. The weight of the beam is $w = 2 \times 2 \times 3\frac{1}{2} \times 0.94 = 12.53$ pounds per linear foot or 1.044 pounds per linear inch; the bending moment is $M = \frac{1}{2} \times 1.044l^2 = 0.522l^2$ pound-inches, where l is in inches; the value of I/c is $\frac{1}{8}bd^2 = 1.333$ inches³. Inserting these in the formula it becomes $0.522l^2 = 35\ 000 \times 1.333$, from which $l = 299$ inches or about 25 feet.

The computed flexural strength S_f is often called the 'modulus of rupture,' but the name above employed is a better one because it points out the origin and meaning of the quantity.

Prob. 52a. Compute the size of a square wooden simple beam of 8 feet span in order to break under its own weight.

Prob. 52b. A cast-iron simple beam 2 inches square and 12 feet long carries two equal loads at the quarter points. Find the loads which will cause rupture.

ART 53. MOVING LOADS

The loads upon a beam consist of its own weight and the weight of the uniform or concentrated loads which it carries. These are called 'Dead Loads' when they are permanent in position and 'Live Loads' when they may move. Beams used in buildings are subject to the dead load of the floor and to the live load of a crowd of people; beams used in bridges are subject to the dead load of their own weight and to other permanent

loads, but they receive the greatest stress from the live load of moving wheels or of crowds of people. In the preceding articles dead loads have alone been generally considered, but it has been recognized that the maximum moment due to a single concentrated load on a simple beam occurs when it is placed at the middle of the span. Other cases of concentrated loads will now be discussed.

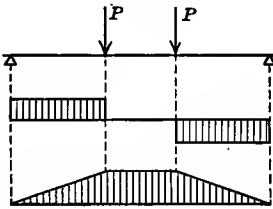

Fig. 53a

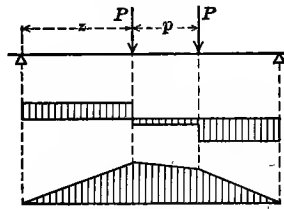

Fig. 53b

When two wheels which are at fixed distance apart, like two wagon-wheels on separate axles, roll over a beam, it might be thought that the greatest moment due to them would occur when they are on opposite sides of the middle and equally distant from it, as in Fig. 53a, but this is not the case. To find the position which will give the greatest moment, let l be the span, p the distance between the loads, and z the distance from the left support to one of the loads, as in Fig. 53b. The maximum moment will occur under one of these loads, as the shear and moment diagrams show. The left reaction is found from $R_1 l = P(l - p - z) + P(l - z)$ and the moment under the first load then is $M = (P/l)(2lz - pz - 2z^2)$. By the usual method, the value of z which renders M a maximum is found to be $z = \frac{1}{2}l - \frac{1}{4}p$, so that the center of gravity of the two loads is as far to the right of the middle as the dangerous section is to the left of the middle. For example, let each load be 3 000 pounds, their distance apart be 5 feet, and the span be 15 feet; then $z = 6.25$ feet, the left reaction is $R_1 = 2\,500$ pounds, and the maximum bending moment is $M = 2\,500 \times 6.25 = 15\,625$ pound-feet. If these loads are placed as in Fig. 53a, the reaction is 3 000 pounds and the moment is $3\,000 \times 5.0 = 15\,000$ pound-feet.

When two unequal loads P_1 and P_2 roll over a simple beam, let z be the distance from the left support to P_1 , and p be the distance from the greater load P_1 to the smaller one P_2 . Then, proceeding as before, it is easy to show that the maximum moment occurs under the first load when the distance between the first load and the center of gravity of the two loads is bisected by the middle of the span. When there are three or more concentrated loads, the section of maximum moment does not always lie under the first load, but the general rule always holds good that the distance between that section and the center of gravity of the loads is bisected by the middle of the span.

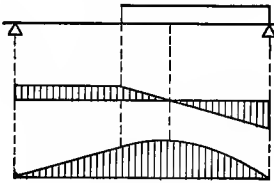

Fig. 53c

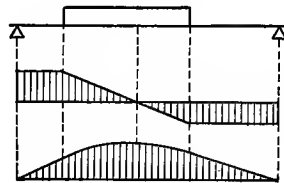

Fig. 53d

When a uniform live load moves over a simple beam there is, for any given position of the same, a section of maximum moment, this being where the shear passes through zero (Art. 47). Such cases, with their shear and moment diagrams, are shown in the two figures above, but it is rarely necessary to compute these moments, because the absolute maximum moment occurs when the uniform live load covers the entire beam, and this is liable to take place at any time. It is, however, of great importance that the student should be able readily to draw the shear and moment diagrams for any assigned position of the live load, whether it be uniform or partly uniform and partly concentrated.

The maximum shear due to a live load occurs when the load is placed so as to give the greatest shear at one of the supports. Thus the maximum shear due to the live load in Fig. 53b occurs at one of the supports when one load is just about to pass upon that support and its numerical value is $zP - P \cdot p/l$.

By the use of the shear formula $S_s a = V$ and the flexure formula $SI/c = M$, the unit-stresses S_s and S are computed for live loads,

after the maximum values of V and M have been found, in the same manner as if the loads were dead. Live load, however, really produces greater stresses than dead load and hence the computed values of S_s and S are increased in practice according to the rules stated in Art. 136.

Prob. 53a. Three loads, spaced 4 feet apart, one being 3 000 and the others 1 500 pounds, roll over a simple beam of 21 feet span. Find the position of these loads which will give the maximum moment and compute its value.

Prob. 53b. For Fig. 53b find the position of the live load which gives the maximum shear at the middle of the span and compute its value. Find also the position which gives maximum shear at the quarter point of the span and compute its value.

ART. 54. DEFLECTION OF CANTILEVER BEAMS

In Art. 45 the differential equation of the elastic curve was deduced and the general method of applying it to a particular case was indicated. The origin of coordinates may be taken at any point in the plane, but for a cantilever beam it is most convenient to take it at the free end, since the algebraic work is thus simplified. In the equation $EI \cdot \delta^2 y / \delta x^2 = M$, the bending moment M is to be expressed in terms of the abscissa x , and by two integrations the equation between y and x is deduced.

Case I. Uniform Load.—Let x and y be the coordinates of the elastic curve with respect to rectangular axes through the free end of the beam, as in Fig. 54a. Let the uniform load per linear unit be w ; then for any section $M = -\frac{1}{2}wx^2$, and the general formula becomes $EI \cdot \delta^2 y / \delta x^2 = -\frac{1}{2}wx^2$. Integrating this, there is found,

$$EI \frac{\delta y}{\delta x} = -\frac{1}{6}wx^3 + C$$

in which C is the constant of integration and $\delta y / \delta x$ is the tangent of the angle which the tangent to the elastic curve makes with the axis of abscissas. To determine this constant, consider that $\delta y / \delta x$ becomes zero when x equals the length of the

beam, l ; hence the value of C is $\frac{1}{8}wl^3$ and then,

$$EI \frac{\delta y}{\delta x} = \frac{1}{8}wl^3 - \frac{1}{8}wx^3$$

Integrating again, and determining the constant by the condition that y equals zero when x equals zero, there results,

$$24EIy = w(4l^3x - x^4)$$

which is the equation of the elastic curve. When $x=l$, the value of y is the deflection of the end of the beam below that at the wall and this will be designated by f . Accordingly,

$$f = \frac{1}{8}wl^4/EI \quad \text{or} \quad f = \frac{1}{8}Wl^3/EI$$

is the deflection of the end of a cantilever beam under the uniform load W , if the elastic limit of the material be not exceeded.

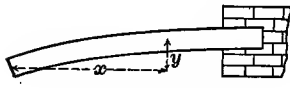

Fig. 54a

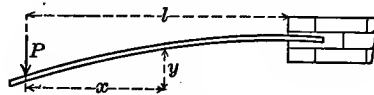

Fig. 54b

Case II. Load P at the Free End.—Take the origin at the free end, as in Fig. 54b, and let x and y be the coordinates of the elastic curve at any section. The bending moment M is $-Px$, and the general equation is $EI \cdot \delta^2 y / \delta x^2 = -Px$. By integration there results $EI \cdot \delta y / \delta x = -\frac{1}{2}Px^2 + C$ and C is determined by the condition that the tangent $\delta y / \delta x$ becomes zero when $x=l$. Hence $EI \cdot \delta y / \delta x = \frac{1}{2}P(l^2 - x^2)$, and the second integration gives for the elastic curve $EI \cdot y = \frac{1}{2}Pl^2x - \frac{1}{6}Px^3$, the constant being zero because y becomes zero when x is zero. When $x=l$ the value of y is the maximum deflection f , and $f = \frac{1}{3}Pl^3/EI$, which is $2\frac{2}{3}$ times as great as the deflection due to the same load uniformly distributed over the length.

Case III. Load P at any Point.—Let κl be the distance of the load from the left end as in Fig. 54c, where l is the length of the beam and κ any number less than unity. Take the origin of coordinates under the load, then by the preceding case the deflection under the load is $\frac{1}{3}P(l - \kappa l)^3/EI$. The free end, however, is lower than the load and since $M=0$ on the left of the load, the radius of curvature of the elastic curve is there infinite

(Art. 45) and that curve is a straight line. Let $\tan \theta$ be the tangent of the angle which the tangent to the elastic curve under the load makes with the horizontal; then the free end is lower than the load by the amount $\kappa l \tan \theta$. The value of $\tan \theta$ is determined from Case II, by making $x=0$ and $l=l-\kappa l$ in the expression for $\delta y/\delta x$, and thus the value of $\kappa l \tan \theta$ is found to be $\frac{1}{2}Pl^3\kappa(1-\kappa)^2/EI$. Therefore, by adding the two quantities,

$$f = Pl^3(2 - 3\kappa + \kappa^3)/6EI$$

which is the deflection of the free end due to the given load. When $\kappa=1$, the load is at the wall and $f=0$; when $\kappa=0$ the load is at the free end and f becomes the same as in the preceding case.

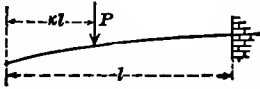

Fig. 54c

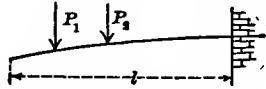

Fig. 54d

Case IV. Several Loads.—For a uniform load and a load P at the end, the value of M is $-\frac{1}{2}wx^2 - Px$. By integration it is found that the ordinate y is the sum of those due to W and P separately, and,

$$f = (\frac{1}{8}W + \frac{1}{3}P)l^3/EI$$

is the deflection of the free end. Similarly, for any number of loads, the deflection is the sum of the deflections due to the loads taken separately; hence, as in cases of axial stress, each load produces its effect independently of others. In order that this deflection may be found correctly from the formulas, it is necessary that the maximum unit-stress S computed for all the loads from the flexure formula $S \cdot I/c = M$ shall not exceed the elastic limit of the material.

In all cases the deflection of a cantilever beam of uniform section varies directly as the load and the cube of the length, and inversely as E and I . For a rectangular section, $I = \frac{1}{12}bd^3$, so that the deflection varies inversely as the breadth and inversely as the cube of the depth. These laws also hold for the simple beams discussed in the next article.

Prob. 54a. In order to find the modulus of elasticity of a cast-iron bar 2 inches wide, 4 inches deep, and 6 feet long, it was balanced upon a support and a weight of 4 000 pounds hung at each end, causing a deflection of 0.401 inches. Compute the value of E .

Prob. 54b. A wooden cantilever, 3 inches wide, 4 inches deep, and 15 feet long, carries two equal loads as shown in Fig. 54d, one being 5 feet from the end and the other 10 feet from the end. Compute the weight of these loads so that the maximum unit-stress S may be two-thirds of the elastic limit. Compute the deflection at the end due to the two loads.

ART. 55. DEFLECTION OF SIMPLE BEAMS

The deflection of a simple beam due to a load at the middle, or to a uniform load, is readily obtained from the expressions just deduced for cantilever beams. Thus, for a simple beam of span l with a load P at the middle, let Fig. 55a be inverted and it will be seen to be equivalent to two cantilever beams of length $\frac{1}{2}l$ with a load $\frac{1}{2}P$ at each end. The formula for the maximum deflection of a cantilever beam hence applies to this figure, if l be replaced by $\frac{1}{2}l$ and P by $\frac{1}{2}P$ which gives $f = P^3/48EI$ for the deflection at the middle of the simple beam. It will be well, however, to use the general formula (45) and discuss each case independently.

Case I. Uniform Load.—Let w be the load per linear unit and x the distance of any section from the left end. For this section $M = \frac{1}{2}wlx - \frac{1}{2}wx^2$ and the differential equation of the elastic curve is,

$$EI \frac{\delta^2 y}{\delta x^2} = \frac{1}{2}wlx - \frac{1}{2}wx^2$$

Integrate this and find the constant by the condition that the tangent $\delta y/\delta x$ equals zero when x is $\frac{1}{2}l$; then,

$$EI \frac{\delta y}{\delta x} = \frac{1}{4}wlx^2 - \frac{1}{6}wx^3 - \frac{1}{24}wl^3$$

Integrating again and determining the constant by the condition that y is zero when x is zero, there is found,

$$24EIy = w(-x^4 + 2lx^3 - l^3x)$$

Now, making $x = \frac{1}{2}l$, the value of y is the deflection f , which is negative because it is measured downward from the axis of abscissas through the supports. It is, however, unnecessary to write this sign, and hence,

$$f = \frac{5}{384} \frac{wl^4}{EI} \quad \text{or} \quad f = \frac{5}{384} \frac{Wl^3}{EI}$$

is the elastic deflection of the simple beam under the uniform load W .

Case II. Load P at the Middle.—As before let the origin be taken at the left support, as in Fig. 55a. For any section between the left support and the middle $M = \frac{1}{2}Px$ and the differential equation of the elastic curve is $EI \cdot \delta^2y/\delta x^2 = \frac{1}{2}Px$. Integrate this and find the constant by the evident condition that $\delta y/\delta x = 0$ when $x = \frac{1}{2}l$. Then integrate again and find the constant by the fact that $y = 0$ when $x = 0$. Thus,

$$48EIy = P(4x^3 - 3l^2x)$$

is the equation of elastic curve between the left-hand support and the load. For the greatest deflection make $x = \frac{1}{2}l$, then,

$$f = \frac{1}{48} \frac{Pl^3}{EI}$$

is the deflection due to the single load P at the middle, which is 1.6 times as great as that due to the same uniform load.

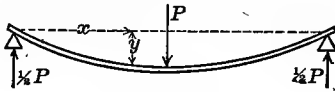

Fig. 55a

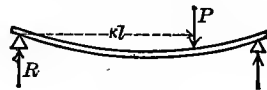

Fig. 55b

Case III. Load P at any Point.—Here the expressions for the moment M are different on opposite sides of the load, and hence there are two elastic curves which have distinct equations but which have a common tangent and ordinate under the load. As in Fig. 55b let the load be placed at a distance κl from the left support, κ being a number less than unity. Then the left reaction is $R = P(1 - \kappa)$. From the general equation (45), with the origin at the left support, there are found,

On the left of the load,

$$(a) \quad EI \frac{\delta^2 y}{\delta x^2} = Rx \qquad (b) \quad EI \frac{\delta y}{\delta x} = \frac{1}{2} Rx^2 + C_1$$

$$(c) \quad EI y = \frac{1}{6} Rx^3 + C_1 x + C_2$$

On the right of the load,

$$(a)' \quad EI \frac{\delta^2 y}{\delta x^2} = Rx - P(x - \kappa l)$$

$$(b)' \quad EI \frac{\delta y}{\delta x} = \frac{1}{2} R x^2 - \frac{1}{2} P x^2 + P \kappa l x + C_3$$

$$(c)' \quad EI y = \frac{1}{6} R x^3 - \frac{1}{6} P x^3 + \frac{1}{2} P \kappa l x^2 + C_3 x + C_4$$

To determine the constants consider in (c) that $y = 0$ when $x = 0$, and hence that $C_2 = 0$. Also in (c)', $y = 0$ when $x = l$; again, since the curves have a common tangent under the load, (b) equals (b)' when $x = \kappa l$, and since they have a common ordinate at that point (c) equals (c)' when $x = \kappa l$. Or,

$$0 = \frac{1}{6} R l^3 - \frac{1}{6} P l^3 + \frac{1}{2} P \kappa l^3 + C_3 l + C_4$$

$$\frac{1}{2} R \kappa^2 l^2 + C_1 = \frac{1}{2} R \kappa^2 l^2 + \frac{1}{2} P \kappa^2 l^2 + C_3$$

$$\frac{1}{6} R \kappa^3 l^3 + C_1 \kappa l = \frac{1}{6} R \kappa^3 l^3 + \frac{1}{2} P \kappa^3 l^3 + C_3 \kappa l + C_4$$

From these three conditions the values of C_1 , C_3 , and C_4 are determined. Then the equation of the elastic curve on the left of the load is found to be,

$$6EIy = P(1 - \kappa)x^3 - P(2\kappa - 3\kappa^2 + \kappa^3)l^2x$$

To ascertain the maximum deflection, the value of x which renders y a maximum is to be obtained by equating the first derivative to zero. If κ is greater than $\frac{1}{2}$, this value of x inserted in the above equation gives the maximum deflection; if κ is less than $\frac{1}{2}$, the maximum deflection is on the other side of the load. For instance, if $\kappa = \frac{3}{4}$, the equation of the elastic curve on the left of the load is, $384EIy = 16Px^3 - 15Pl^2x$, and y has its maximum value when $x = 0.559l$. The greatest possible deflection due to a single load occurs when it is at the middle of the span and its value is that deduced in Case II.

Case IV. Several Loads.—Here, as for cantilevers, the deflection due to several loads is obtained by taking the sum of the several deflections; but it must be carefully noted that the computed value will be correct only when the unit-stress S at the dangerous section is less than the elastic limit of the material. The above formula for the deflection due to a load at the middle is frequently used to determine the modulus of elasticity E , several

values of f being measured for several different loads, in order to obtain a mean value of E .

Prob. 55a. When κ is greater than $\frac{1}{2}$ in Fig. 55b, show that the maximum deflection is $f = P^3(1 - \kappa)(\frac{2}{3}\kappa - \frac{1}{3}\kappa^2)^{\frac{3}{2}}/3EI$.

Prob. 55b. In order to find the modulus of elasticity of *Quercus alba*, a bar 4 centimeters square and one meter long was supported at the ends, and loaded in the middle with weights of 50 and 100 kilograms, measured deflections being 6.6 and 13.0 millimeters. Compute the mean value of E in kilograms per square centimeter.

ART. 56. COMPARATIVE STRENGTH AND STIFFNESS

The strength of a bar under tension is measured by the load that it can carry with an assigned unit-stress. In the same manner the strength of a beam is measured by the load that it can carry with an assigned unit-stress on the remotest fiber at the dangerous section. Let it be required to determine the relative strength of the four following cases,

- 1st, A cantilever loaded at the end with W
- 2nd, A cantilever uniformly loaded with W
- 3rd, A simple beam loaded at the middle with W
- 4th, A simple beam loaded uniformly with W

Let l be the length in each case. Then, from Art. 47 and the flexure formula $M = S \cdot I/c$, there is found,

$$\begin{aligned} \text{for 1st, } M &= Wl & \text{and hence } W &= SI/cl \\ \text{for 2nd, } M &= \frac{1}{2}Wl & \text{and hence } W &= 2 \cdot SI/cl \\ \text{for 3rd, } M &= \frac{1}{4}Wl & \text{and hence } W &= 4 \cdot SI/cl \\ \text{for 4th, } M &= \frac{1}{8}Wl & \text{and hence } W &= 8 \cdot SI/cl \end{aligned}$$

Therefore the comparative strengths of the four cases are as the numbers 1, 2, 4, 8. That is, if four such beams be of equal size and length and of the same material, the second is twice as strong as the first, the third four times as strong, and the fourth eight times as strong. From these equations also result the following important laws:

The strength of a beam varies directly as S , directly as I , inversely as c , and inversely as the length l .

A load uniformly distributed produces only one-half as much stress as the same load when concentrated.

These apply to all cantilever and simple beams whatever be the shape of the cross-section.

When the cross-section is rectangular, let b be the breadth and d the depth, then the value of I/c is $\frac{1}{6}bd^2$ and the above equations become $W = \alpha Sbd^2/6l$, where the number α is 1, 2, 4, or 8 as the case may be. Therefore,

The strength of a rectangular beam varies directly as its breadth, directly as the square of its depth, and inversely as its length.

The reason why rectangular beams are put with the greatest dimension vertical is thus again shown.

In the above equations the load W is the allowable load when S is the allowable unit-stress, and W is the load which will rupture the beam when S is the fictitious ultimate flexural unit-stress whose mean values are given in Art. 52.

The stiffness of a bar under tension is measured by the load that it can carry with a given elongation. Similarly the stiffness of a beam is indicated by the load that it can carry with a given deflection. For the two preceding articles the values of W for the four common cases of cantilever and simple beams are,

$$\begin{array}{ll} \text{for a cantilever loaded at the end,} & W = 3 \cdot EIf/l^3 \\ \text{for a cantilever uniformly loaded,} & W = 8 \cdot EIf/l^3 \\ \text{for a simple beam loaded at middle,} & W = 48 \cdot EIf/l^3 \\ \text{for a simple beam uniformly loaded,} & W = 384 \cdot EIf/l^3 \end{array}$$

which show that the relative stiffness of these four cases are as the numbers 1, $2\frac{2}{3}$, 16, and $25\frac{3}{8}$.

These equations also show that the stiffness of a beam, when the greatest unit-stress does not exceed the elastic limit of the material, varies directly as E and I and inversely as the cube of the length. It thus appears that the laws of stiffness are very different from those of strength. For a rectangular section $I = \frac{1}{12}bd^3$, and hence the stiffness varies directly as the breadth and directly as the cube of the depth.

The four cases above discussed have given the following expressions for the allowable load; for the strength of the beam

$$W = \alpha \cdot SI/cl \quad \text{where } \alpha = 1, 2, 4, \text{ or } 8$$

and for the stiffness of the beam,

$$W = \beta \cdot EI/f^3 \quad \text{where } \beta = 3, 8, 48, \text{ or } 76\frac{1}{2}$$

By equating these values of W , the following relations between the unit-stress S and the deflection f are obtained,

$$S/f = \beta Ec/al^2 \quad \text{or} \quad \beta Ecf = \alpha Sl^2 \quad (56)$$

which are only valid when S is less than the elastic limit of the material. These equations show that the deflection f , for similar beams of the same material under the same unit-stress S , varies as l^2/c .

Table 11, at the end of this volume, recapitulates the important facts regarding strength, deflection, and stiffness, which have been deduced in the preceding articles.

Prob. 56a. Compare the strength of a joist 3×8 inches when laid with long side vertical with that when it is laid with short side vertical. Compare also the stiffnesses.

Prob. 56b. Find the deflection of the lightest steel 10-inch I beam, 9 feet in span, when stressed by a uniform load up to 30 000 pounds per square inch.

Prob. 56c. Compare the working strength of a light 9-inch steel I beam with that of a wooden beam 8×12 inches in section, the span being the same for both.

ART. 57. CANTILEVER BEAMS OF UNIFORM STRENGTH

All beams thus far discussed have been of constant cross-section throughout their entire length. But in the flexure formula $S \cdot I/c = M$, the unit-stress S is proportional to the bending moment M , and hence varies throughout the beam in the same way as the moments vary. Accordingly some parts of the beam are but slightly stressed in comparison with the dangerous section, and perhaps more material is used than is necessary.

A beam of uniform strength is one so shaped that the unit-stress S is the same in all sections at the upper and lower sur-

faces. Hence to ascertain the form of such a beam the unit-stress S must be taken as constant and I/c be made to vary with M . The discussion will be given only for the simplest cases, namely, those where the sections are rectangular, the breadth being b and the depth d . For these $I/c = \frac{1}{6}bd^2$, and the flexure formula becomes,

$$\frac{1}{6}Sbd^2 = M \quad \text{or} \quad bd^2 = 6M/S$$

In this bd^2 must be made to vary with M in order to give forms of uniform strength.

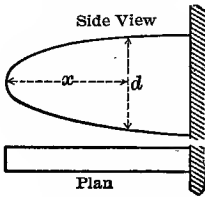

Fig. 57a

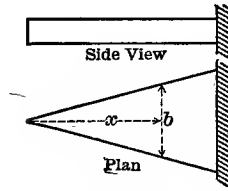

Fig. 57b

For a cantilever beam with a load P at the end, the value of M without regard to sign is Px and the equation becomes $\frac{1}{6}Sbd^2 = Px$, in which P and S are constant. If the breadth is taken as constant, d^2 varies with x and the profile is that of a parabola having its vertex at the free end. The depth d_1 of the beam at the wall is found from $\frac{1}{6}Sbd_1^2 = Pl$, and comparing this with the first equation there results the simpler form $d = d_1\sqrt{x/l}$ for the relation between d and x ; Fig. 57a shows a profile plotted from this equation. When the depth of the cantilever beam is constant, then b varies directly as x and the plan of the beam is a triangle, as shown in Fig. 57b; the breadth b_1 at the wall is found from $\frac{1}{6}Sd^2b_1 = Pl$, and hence equation between b and x is more simply expressed by $b = (b_1/l)x$.

For a cantilever beam uniformly loaded with w per linear unit $M = \frac{1}{2}wx^2$, and the equation becomes $\frac{1}{6}Sbd^2 = \frac{1}{2}wx^2$, in which w and S are known. If the breadth is taken as constant, then d varies as x and the side view is a triangle, as in Fig. 57c, where the depth at any point is given by $d = (d_1/l)x$, the depth d_1 being that at the wall, which is determined from $\frac{1}{6}Sbd_1^2 = \frac{1}{2}wl^2$. If, however, the depth is taken as constant, then b varies as x^2 ,

and b may be found from $b = b_1(x/l)^2$, where b_1 is the breadth at the wall; this is the equation of a parabola having its vertex at the free end and its axis vertical, or the plan of the beam may be formed by two parabolas as shown in Fig. 57*d*.

The vertical shear modifies in practice the shape of these forms near their ends. For instance, a cantilever beam loaded at the end with P requires a section area at the end equal to P/S_s , where S_s is the allowable shearing unit-stress. This section area should continue until a value of x is reached where the same section area is found from the equation of the form of uniform strength. Exact agreement with theoretic conditions is rarely possible on account of the expense of manufacture, and in fact cast iron is the only material which has been advantageously used for these forms. A cantilever of structural steel is built in a different way (Art. 58).

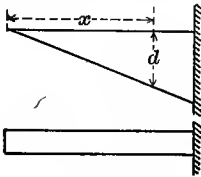
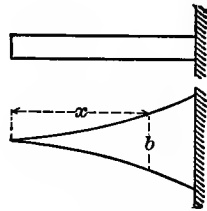
Fig. 57*c*Fig. 57*d*

The deflection of a cantilever beam of uniform strength is evidently greater than that of one of constant cross-section, since the unit-stress S which acts only at the wall in the latter case, acts throughout the entire length in the former. In any case it may be determined from the general formula $EI \cdot \delta^2 y / \delta x^2 = M$ by substituting for M and I their values in terms of x , integrating twice, determining the constants, and then making x equal to l for the maximum value of y .

For a cantilever beam loaded at the end and of constant breadth, as in Fig. 57*a*, this formula becomes,

$$\frac{\delta^2 y}{\delta x^2} = \frac{12Px}{Ebd^3} = \frac{12Pl^3}{Ebd_1^3} x^{-4}$$

Integrating twice and determining the constants, as in Art. 54,

the equation of the elastic curve is found to be,

$$y = \frac{24Pl^3}{Ebd_1^3} \left(\frac{2}{3}x^3 - l^2x \right)$$

In this let $x=l$, then y is the deflection f of the end, and $f = 8Pl^3/Ebd_1^3$, which is double the deflection of a cantilever beam of uniform section and depth d_1 .

For a cantilever beam loaded at the end and of constant depth, the general formula becomes,

$$\frac{\partial^2 y}{\partial x^2} = \frac{12Px}{Ebd^2} = \frac{12Pl}{Eb_1d^2}$$

By integrating this twice and determining the constants as before, the equation of the elastic curve is found, whence the deflection is $f = 6Pl^3/Eb_1d^3$ which is fifty percent greater than that of a cantilever of uniform section and breadth b_1 .

Prob. 57. A cast-iron cantilever beam of uniform strength is to be 4 feet long, 3 inches in breadth, and to carry a load of 15 000 pounds at the end. Find the proper depths for every foot in length, using 3 000 pounds per square inch for the horizontal unit-stress, and 4 000 pounds per square inch for the shearing unit-stress.

ART. 58. SIMPLE BEAMS OF UNIFORM STRENGTH

In the same manner as that of the last article it is easy to deduce the forms of uniform strength for simple beams of rectangular cross-section.

For a load at the middle and breadth constant, $M = \frac{1}{2}Px$, and hence, $\frac{1}{8}Sbd^2 = \frac{1}{2}Px$. Accordingly $d^2 = (3P/Sb)x$, from which values of d may be found for assumed values of x . Here the profile of the beam will be parabolic, the vertex being at the support, and the maximum depth under the load; if d_1 is the depth at the middle, the equation of the parabola becomes $d^2 = d_1^2(x/\frac{1}{2}l)$.

For a load at the middle and depth constant, $M = \frac{1}{2}Px$ as before. Hence $b = (3P/Sd^2)x$, and the plan must be triangular or lozenge-shaped, the width uniformly increasing from the support to the load. If b_1 is the breadth at the middle, the equation of the line becomes $b = b_1(x/\frac{1}{2}l)$.

For a uniform load and constant breadth, $M = \frac{1}{2}wlx - \frac{1}{2}wx^2$, and hence, $d^2 = (3w/Sb)(lx - x^2)$, and the profile of the beam must be elliptical, or preferably a half-ellipse. If d_1 is the depth at the middle the equation of the ellipse becomes $d^2 = (4d_1^2/l^2)(lx - x^2)$.

For a uniform load and constant depth, $b = (3w/Sd^2)(lx - x^2)$, hence the plan should be formed of two parabolas having their vertices at the middle of the span. If b_1 is the breadth at the middle of the span, this equation becomes $b = (4b_1^2/l^2)(lx - x^2)$.

The figures for these four cases are purposely omitted, in order that the student may draw them for himself; if any difficulty be found in doing this, let numerical values be assigned to the constant quantities in each equation and the variable breadth or depth be computed for different values of x .

In the same manner as in the last article, it can be shown that the deflection of a simple beam of uniform strength loaded at the middle is double that of one of constant cross-section when the breadth is constant, and is one and one-half times as much when the depth is constant.

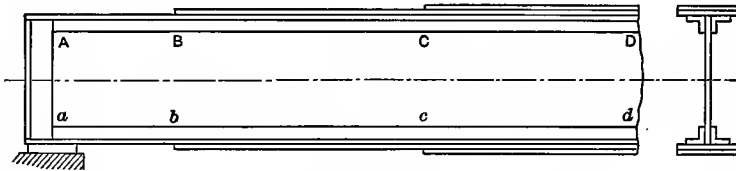

Fig. 58

Cast-iron simple beams are sometimes made approximately in the forms required by the above equations, care being taken to provide sufficient sectional area near the supports to safely carry the vertical shears; such beams are mainly used in machine-shops on planers to carry the cutting tool. Travelling cranes used in shops are also approximately of this form, but these are made by riveting steel plates and shapes so that the section areas are not rectangular.

Plate girders, used extensively in buildings and bridges, are made by riveting together four angles, a web plate, and cover plates. Fig. 58 shows the general arrangement without the

rivets. The section at A is made ample to resist the shear and that at B to resist either shear or moment; there being no cover plates on the distance AB . Between B and C two cover plates are used to provide sufficient section for the moment at C , while between C and D two additional cover plates are added so that the section at the middle D will be sufficient to resist the maximum moment at that place. A plate girder, then, is approximately a beam of uniform strength.

Prob. 58a. Draw the profile for a cast-iron simple beam of uniform strength, the span being 8 feet, breadth 3 inches, and load at the middle 30 000 pounds; using the same working unit-stresses as in Prob. 57.

Prob. 58b. Compute the deflection of a steel spring of constant depth and uniform strength which is 6 inches wide at the middle, 52 inches long, and loaded at the middle with 600 pounds, the depths being such that the uniform fiber stress is 20 000 pounds per square inch.

CHAPTER VII

OVERHANGING AND FIXED BEAMS

ART. 59. BEAM OVERHANGING ONE SUPPORT

A beam is said to be 'fixed' at a support when it is subject to such constraint that the elastic curve is there horizontal. The cantilevers discussed in the preceding articles have been fixed at one end by the restraint of the wall and the maximum moment has been found to occur at that end. Beams are sometimes fixed at one end and supported at the other (Art. 60) and sometimes fixed at both ends (Art. 62). The effect of this restraint is to diminish the deflection, and hence the strength and stiffness are usually increased.

Beams overhanging one support, as in the following figures, may be said to be fixed when the lengths and loads have such values that the tangent to the elastic curve at that support is horizontal. This condition is rarely fulfilled, but the discussion of overhanging beams is very useful and important. A cantilever beam has its upper fibers in tension and the lower in compression, while a simple beam has its upper fibers in compression and the lower in tension. Evidently a beam overhanging one support has its overhanging part in the condition of a cantilever and the part near the other end in the condition of a simple beam. Hence there must be a point where the curvature changes from positive to negative, and where the fiber stresses change from tension to compression. This point i is called the 'Inflection Point'; it is the point where the bending moment is zero, for if the curvature changes from positive to negative, M must do likewise (Art. 45). An overhanging beam is said to be subject to a constraint at the support beyond which the beam projects, or, in other words, there is a stress in the horizontal fibers over that support.

Since the beam has but two supports, its reactions may be

found by using the principle of moments as in Art. 36. Thus, if the distance between the supports be l , the length of the overhanging part be m , and the uniform load per linear foot be w , the two reactions for Fig. 59a are,

$$R_1 = \frac{1}{2}wl - \frac{1}{2}wm(m/l) \qquad R_2 = \frac{1}{2}wl + wm + \frac{1}{2}wm(m/l)$$

From these the vertical shear at any section may be computed from its definition in Art. 37 and the bending moment from its definition in Art. 38, bearing in mind that for a section beyond the right support the reaction R_2 must be considered as a force acting upward. Thus, for any section distant x from the left support,

When x is less than l

$$V = R_1 - wx$$

$$M = R_1x - \frac{1}{2}wx^2$$

When x is greater than l

$$V = R_1 + R_2 - wx$$

$$M = R_1x + R_2(x-l) - \frac{1}{2}wx^2$$

The curves corresponding to these equations are shown on Fig. 59a. The shear curve consists of two straight lines; $V=R$ when $x=0$, and $V=0$ when $x=R_1/w$; at the right support $V=R_1-wl$ from the first equation; $V=R_1+R_2-wl$ from the second, and $V=0$ when $x=l+m$. The moment curve consists of two parts of parabolas; $M=0$ when $x=0$, and M is a maximum where the shear passes through zero; at the inflection point $M=0$ and $x=2R_1/w$; also M has its maximum negative value at the right support where the shear again passes through zero, and $M=0$ when $x=l+m$. The diagrams show clearly the distribution of shears and moments throughout the beam.

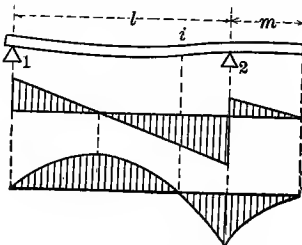

Fig. 59a

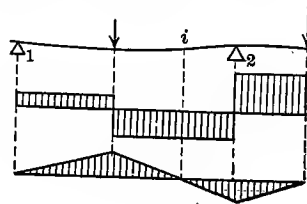

Fig. 59b

In any particular case it is best to work out the numerical values without using the above algebraic expressions. For example, if $l=20$ feet, $m=10$ feet, and $w=40$ pounds per linear

foot, the reactions are $R_1 = 300$ and $R_2 = 900$ pounds. Then the point of zero shear or maximum moment is at $x = 7.5$ feet, the inflection point at $x = 15$ feet, the maximum shears are $+300$, -500 , and $+400$ pounds, and the maximum bending moments are $+1125$ and -2000 pound-feet. Here the negative bending moment at the right support is numerically greater than the maximum positive moment. The relative values of the two maximum moments depend on the ratio of m to l ; if $m = 0$, there is no overhanging part and the beam is a simple one; if $m = \frac{1}{2}l$, the case is that just discussed; if $m = l$, the reaction R_1 is zero, and each part is a cantilever beam.

After having thus found the maximum values of V and M the beam may be investigated by the application of the shear and flexure formulas of Art. 41 in the same manner as a cantilever or simple beam. By the use of formula (45) the equation of the elastic curve between the two supports may be deduced by two integrations and the proper determination of the constants, and it is,

$$24EIy = 4R_1(x^3 - l^2x) - w(x^4 - l^3x)$$

From this the maximum deflection for any particular case may be determined by obtaining the derivative of y with respect to x , equating it to zero, solving for x , and then finding the corresponding value of y .

If concentrated loads be placed at given positions on the beam the reactions are found by the principle of moments, and then the entire investigation can be made by the methods above described. Fig. 59*b* shows the shear and moment diagram for two loads and here, as always, the maximum moments occur at the sections where the shears change sign.

Prob. 59*a*. Three men carry a stick of timber, one taking hold at one end and the other two at a common point. Where should this point be so that each may bear one-third the weight? Draw the shear and moment diagrams.

Prob. 59*b*. A beam 20 feet long has one support at the right end and one support at 5 feet from the left end. At the left end is a load of 180 pounds, and at 6 feet from the right end is a load of 125 pounds.

Find the reactions, the inflection point, and draw the shear and moment diagrams.

ART. 60. BEAM FIXED AT ONE END

A beam with one overhanging end, as in Fig. 59*a*, has the span l in the condition of a beam fixed at the right end and supported at the other, when the length m is such that the tangent to the elastic curve is horizontal over the right support. Fig. 60*a* shows the practical arrangement of such a beam, the right end being held horizontal by the restraint of the wall. The usual arrangement where the left support is on the same level as the lower side of the beam at the wall will now be discussed, the section area of the beam being constant through its length.

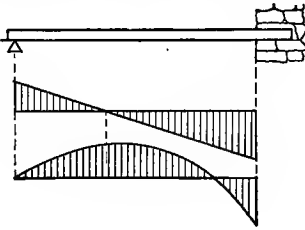

Fig. 60*a*

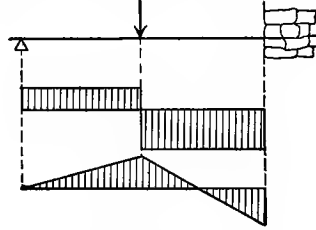

Fig. 60*b*

Case I. Uniform Load.—Let R be the reaction of the left end in Fig. 60*a*, and x the distance from that end to any section. In the general equation of the elastic curve $EI \cdot \delta^2 y / \delta x^2 = M$, the value of M is $Rx - \frac{1}{2}wx^2$. Integrating once, the constant is determined from the condition that $\delta y / \delta x = 0$ when $x = l$. Integrating again the constant is found from the fact that $y = 0$ when $x = 0$; then,

$$24EIy = 4R(x^3 - 3l^2x) - w(x^4 - 4l^3x)$$

Here also $y = 0$ when $x = l$, and therefore $R = \frac{3}{8}wl$; hence the left reaction is three-fourths of that for a simple beam.

The moment at any point now is $M = \frac{3}{8}wlx - \frac{1}{2}wx^2$, and by placing this equal to zero, it is seen that the point of inflection is at $x = \frac{3}{4}l$. The maximum positive moment occurs when $\delta M / \delta x = 0$ or when $x = \frac{3}{8}l$, and its value is $+\frac{9}{128}wl^2$. The maximum negative moment occurs when $x = l$ and its value is $-\frac{1}{8}wl^2$.

The distribution of shears and moments is as shown in the diagrams.

The point of maximum deflection is found from the above equation of the elastic curve; placing the derivative equal to zero there results $8x^3 - 9lx^2 + l^3 = 0$, one root of which is $x = 0.4215l$, while the others are inapplicable to this problem. Hence $f = 0.0054wl^4/EI$ is the value of the maximum deflection.

Case II. Load P at Middle.—Here it is necessary to consider that there are two elastic curves having a common ordinate and a common tangent under the load, since the expression, for the moment are different on opposite sides of the load. Thus taking the origin as usual at the supported end,

On the left of the load,

$$(a) \quad EI \frac{\delta^2 y}{\delta x^2} = Rx \qquad (b) \quad EI \frac{\delta y}{\delta x} = \frac{1}{2} Rx^2 + C_1$$

$$(c) \quad EIy = \frac{1}{6} Rx^3 + C_1x + C_3$$

On the right of the load the similar equations are,

$$(a)' \quad EI \frac{\delta^2 y}{\delta x^2} = Rx - P(x - \frac{1}{2}l)$$

$$(b)' \quad EI \frac{\delta y}{\delta x} = \frac{1}{2} Rx^2 - \frac{1}{2} Px^2 + \frac{1}{2} Plx + C_2$$

$$(c)' \quad EIy = \frac{1}{6} Rx^3 - \frac{1}{6} Px^3 + \frac{1}{4} Plx^2 + C_2x + C_4$$

To determine the constants consider in (c) that $y = 0$ when $x = 0$ and hence that $C_3 = 0$. In (b)' the tangent $\delta y/\delta x = 0$ when $x = l$ and hence $C_2 = -\frac{1}{2}Rl^2$. Since the curves have a common tangent under the load, (b) = (b)' for $x = \frac{1}{2}l$, and thus the value of C_1 is found. Since the curves have a common ordinate under the load, (c) = (c)' when $x = \frac{1}{2}l$, and thus C_4 is found. Then,

$$(c) \quad 24EIy = 4Rx^3 + 3Pl^2x - 12Rl^2x$$

$$(c)' \quad 48EIy = 8Rx^3 - 8Px^3 + 12Plx^2 - 24Rl^2x + Pl^3$$

are the equations of the two elastic curves. Making $x = l$ in (c)' the value of y is zero, and then the left reaction is $R = \frac{5}{16}P$.

The moment on the left of the load is now $M = \frac{5}{16}Px$, and that on the right $M = -\frac{1}{16}Px + \frac{1}{2}Pl$. The maximum positive moment obtains at the load and its value is $\frac{5}{32}Pl$. The

maximum negative moment occurs at the wall, and its value is $\frac{3}{16}Pl$. The inflection point is at $x = \frac{8}{11}l$. The deflection under the load is readily found from (c) by making $x = \frac{1}{2}l$. The maximum deflection occurs at a less value of x , which may be found by equating the first derivative to zero. Fig. 60*b* shows the distribution of shears and moments.

Case III. Load P at any Point.—The distance of the load from the left support being κl the following results may be deduced by a method exactly similar to that of the last case.

$$\text{Reaction at supported end} = \frac{1}{2}P(2 - 3\kappa + \kappa^3)$$

$$\text{Reaction at fixed end} = \frac{1}{2}P(3\kappa - \kappa^3)$$

$$\text{Maximum positive moment} = \frac{1}{2}Pl\kappa(2 - 3\kappa + \kappa^3)$$

$$\text{Maximum negative moment} = \frac{1}{2}Pl(\kappa - \kappa^3)$$

The absolute maximum deflection for this case occurs under the load when $x = 0.414l$, and its value will be found to be given by $f = 0.0098Pl^3/EI$.

Prob. 60*a*. Draw the shear and moment diagrams for a span of 12 feet, due to a load P at 10 feet from the left end.

Prob. 60*b*. Find the position of load P which gives the maximum positive moment. Find also the position which gives the maximum negative moment. Compute these maximum moments and compare them with those due to a load at the middle.

ART. 61. BEAMS OVERHANGING BOTH SUPPORTS

When a beam overhangs both supports, the moments for sections beyond the supports are negative, and in general between the supports there will be two inflection points. If the overhanging lengths are equal, the reactions will be equal under uniform load, each being one-half the total load. In any case, whatever be the kind of loading, the reactions may be found by the principle of moments (Art. 36), and then the vertical shears and bending moments may be deduced for all sections, after which the shear and flexure formulas (Art. 41) can be used for any special problem.

Under a uniformly distributed load, each overhanging end being of length m , and the middle span being l , each reaction is

$wm + \frac{1}{2}wl$, the maximum shears at the supports are wm and $\frac{1}{2}wl$, the maximum moment at the middle is $+w(\frac{1}{8}l^2 - \frac{1}{2}m^2)$, the maximum moment at each support is $-\frac{1}{2}wm^2$, and the inflection points are distant $\frac{1}{2}(l^2 - 4m^2)^{\frac{1}{2}}$ from the middle of the beam. Fig. 61a shows the distribution of moments for this case. When $m=0$, the beam is a simple one; when $l=0$, it consists of two cantilever beams. When m is equal to or greater than $\frac{1}{2}l$, there are no positive moments in the middle span.

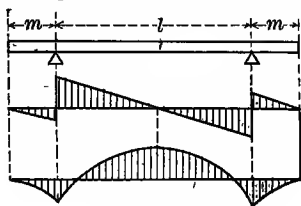

Fig. 61a

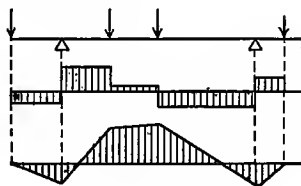

Fig. 61b

When concentrated loads are on the beam, as in Fig. 61b, the reactions are readily found by the method of Art. 36, the shears and moments computed for several sections by the definitions of Arts. 37 and 38, and the shear and moment diagrams may then be drawn. The maximum negative moments occur at the supports and the maximum positive moment under one of the concentrated loads. The final maximum shears and moments due to both uniform and concentrated loads are to be obtained by combining the values found for these loads. When the concentrated loads are light, it often happens that the final maximum positive moment will be between two loads.

Prob. 61a. For Fig. 61a find the ratio of l to m in order that the maximum positive moment may numerically equal the maximum negative moment.

Prob. 61b. A beam 30 feet long has one support at 5 feet from the left end, and the other support at 10 feet from the right end. At each end there is a load of 156 pounds and half-way between the supports there is a load of 344 pounds. Construct the shear and moment diagrams.

Prob. 61c. For Fig. 61a find the ratio of l to m in order that there may be no positive moment.

ART. 62. BEAMS FIXED AT BOTH ENDS

If, in Fig. 61*a*, the distances m be such that the elastic curve over the supports is horizontal, the central span l is said to be a beam fixed at both ends. The length m which will cause the beam to be horizontal at the support can be determined by the help of the elastic curve. For uniform load, the bending moment at any section in the span l distant x from the left support is,

$$M = (wm + \frac{1}{2}wl)x - \frac{1}{2}w(m+x)^2$$

which may be written in the simpler form,

$$M = M_1 + \frac{1}{2}wlx - \frac{1}{2}wx^2$$

where M_1 represents the unknown bending moment $-\frac{1}{2}wm^2$ at the left support. The distance m can hence be found when M_1 has been determined.

Again, for a single load P at the middle of l in Fig. 61*a*, the elastic curve can be regarded as kept horizontal at the left support by a load Q at the end of the distance m . Then the bending moment at any section distant x from the left support, and between that support and the middle, is,

$$M = (Q + \frac{1}{2}P)x - Q(m+x) \quad \text{or} \quad M = M_1 + \frac{1}{2}Px$$

in which M_1 denotes the unknown moment $-Qm$ at the left support. The problem of finding the bending moment at any section hence reduces to that of determining M_1 the moment at the left support,

Case I. Uniform Load.—For this case the differential equation of the elastic curve becomes,

$$EI \frac{\delta^2 y}{\delta x^2} = M_1 + \frac{1}{2}wlx - \frac{1}{2}wx^2$$

Integrating twice, making $\delta y / \delta x = 0$ when $x = 0$ and also when $x = l$, there is found $M_1 = -\frac{1}{4}wl^2$, and the equation of the elastic curve is

$$24EIy = w(-l^2x^2 + 2lx^3 - x^4)$$

from which the maximum deflection is found to be $f = \frac{1}{84}wl^4/EI$. The inflection points are located by placing M equal to zero, which gives $x = \frac{1}{2}l(1 \pm \frac{1}{3}\sqrt{3})$. The maximum positive moment is at the middle and its value is $\frac{1}{24}wl^2$; accordingly the horizontal

stress upon the fibers at the middle of the beam is one-half that at the ends. The vertical shear at the left end is $\frac{1}{2}wl$, at the middle 0, and at the right end $-\frac{1}{2}wl$. Fig. 62a shows the shear and moment diagrams.

Case II. Load P at Middle.—Here the differential equation of the elastic curve is $EI \cdot \delta^2 y / \delta x^2 = M_1 + \frac{1}{2}Px$ and in a manner similar to that of the last case it is easy to find that the maximum negative moments are $\frac{1}{8}Pl$, that the maximum positive moment is $\frac{1}{8}Pl$, that the inflection points are half-way between the supports and the load, and that the maximum deflection is $f = \frac{1}{192}Pl^3/EI$.

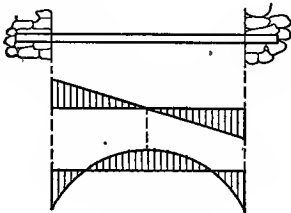

Fig. 62a

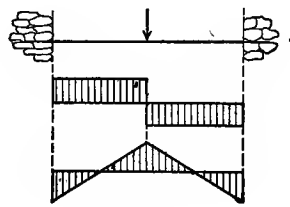

Fig. 62b

Case III. Load P at any Point.—Let the load P be at the distance κl from the left end, κ being any number less than unity. Let M_1 and R_1 denote the unknown bending moment and reaction at that end. Then for any section on the left of the load $M = M_1 + R_1 x$, and for any section on the right of the load $M = M_1 + R_1 x - P(x - \kappa l)$. By inserting these in the differential equation (45), integrating each twice and establishing sufficient conditions to determine the unknown M_1 and R_1 and also the constants of integration, the following results may be deduced:

$$\begin{aligned} \text{Reaction at left end} &= P(1 - 3\kappa^2 + 2\kappa^3) \\ \text{Reaction at right end} &= P\kappa^2(3 - 2\kappa) \\ \text{Moment at left end} &= -Pl\kappa(1 - 2\kappa + \kappa^2) \\ \text{Moment at right end} &= -Pl\kappa^2(1 - \kappa) \\ \text{Moment under load} &= +Pl\kappa^2(2 - 4\kappa + 2\kappa^2) \end{aligned}$$

When $\kappa = \frac{1}{2}$, the load is at the middle and these results reduce to the values found in Case II. The maximum deflection occurs under the load when it is at the middle.

Prob. 62a. From the above results for Case III deduce the positions of the two inflection points. Find the inflection points when two equal loads are at $\frac{1}{4}l$ and $\frac{3}{4}l$ from the left end.

Prob. 62b. What medium-steel I beam is required for a span of 24 feet to support a uniform load of 25 000 pounds with a unit-stress S of 16 000 pounds per square inch, the ends being merely supported? What one is needed when the ends are fixed?

ART. 63. COMPARISON OF BEAMS

As the maximum moments for fixed beams are generally less than for simple beams, their strength is relatively greater. This was to be expected, since the constraint lessens the deflection which would otherwise occur. Under a uniform load W , the maximum moment for a simple beam is $\frac{1}{8}Wl$, that for a beam fixed at one end is $\frac{1}{6}Wl$, and that for a beam fixed at both ends is $\frac{1}{2}Wl$; the fixing of one end does not increase the strength, but the fixing of both ends increases it fifty percent.

For a single load P the maximum moment for a simple beam is $\frac{1}{4}Pl$ and that for a beam fixed at both ends is $\frac{1}{2}Pl$; hence the strength of the latter beam under a concentrated load is double that of the former. For the beam fixed at one end and supported at the other, it may be shown that the maximum positive moment due to a load P is $0.174Pl$ and that the maximum negative moment is $0.192Pl$, the latter occurring when the load is at a distance $0.577l$ from the supported end; hence the strength of this beam is intermediate between that of the simple beam and that of the beam with both ends fixed.

With respect to stiffness, the advantage is always on the side of beams with fixed ends. Under uniform load the deflection of the simple beam is $\frac{5}{384}Wl^3/EI$, while for a beam fixed at both ends it is one-fifth of this amount; hence the beam fixed at both ends is five times as stiff as the simple beam. Under a single load a similar comparison of the deflections shows that the beam fixed at both ends is four times as stiff as the simple beam. For the beam with one end fixed, the degree of stiffness is intermediate between those for the other cases. The advantage of

fixing the ends is hence much greater with respect to stiffness than with respect to strength.

Table 12, at the end of this volume, recapitulates the above results, and also those deduced in Art. 56 for cantilever and simple beams. In all cases W represents the load whether concentrated or uniformly distributed. The results given for beams with horizontal restraint, it may be observed, have been deduced from the equation of the elastic curve, which is only valid when the elastic limit of the material is not exceeded by the unit-stress S at the dangerous section. When beams with one or both ends fixed are loaded so that the elastic limit is exceeded, the above results deduced for reactions, moments, and deflections are not applicable except as approximations.

Let $1/\alpha$ represent the numerical coefficient in the column of maximum moments in Table 12 and $1/\beta$ the numerical coefficient in the column of maximum deflections. Then, as in Art. 56, the relation between the unit-stress S and the deflection f is given by,

$$S/f = \beta Ec / \alpha l^2 \quad \text{or} \quad \alpha S l^2 = \beta E c f$$

provided the elastic limit of the material is not exceeded.

Prob. 63a. For a uniformly loaded beam with equal overhanging ends, derive a formula for the deflection at the middle.

Prob. 63b. Find the deflection of a 9-inch steel I beam of 6 feet span and fixed ends when loaded at the middle so that the tensile and compressive stresses at the dangerous section are 16 800 pounds per square inch.

ART. 64. SUPPORTS ON DIFFERENT LEVELS

For all beams thus far discussed the two supports of the beam have been taken as in the same horizontal plane, this being the usual case in practice. A depression of one support below the level of the other may, however, occur, and its influence will now be considered, this depression being taken as very small so that the length of any small part of the elastic curve does not sensibly differ from that of its horizontal projection (Art. 45).

For the simple beam in Fig. 64a, let the left support be

depressed the distance h below the level of the right support and let the horizontal distance between the supports be l ; then h/l is the tangent of the angle of inclination, or $\tan \theta = h/l$. Now, for a load P at the horizontal distance κl from the left support, the left vertical reaction is found by taking an axis of moments at the right support to be $P(1-\kappa)$ which is independent of θ and the same as if the supports were on the same level. The shears and moments throughout the beam due to the vertical forces are hence unaltered by the inclination. In computing, the fiber unit-stress from the flexure formula $S \cdot I/c = M$, the dimensions used in finding I/c are those of a normal section of the inclined beam, and hence the unit-stress S is that on the inclined upper and lower surfaces of the beam. A simple beam is therefore unaffected by a slight change in the relative levels of its supports, unless it be from the influence of the horizontal forces which must come into play at the supports to prevent sliding.

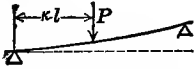

Fig. 64a

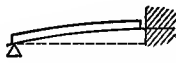

Fig. 64b



Fig. 64c

Let Fig. 64b represent a beam supported at the left end and fixed horizontally at the right end, the vertical distance of the left below the right end being h . Under a uniform load of w per linear unit, the moment at a section distant x from the left end is $M = R_1x - \frac{1}{2}wx^2$, where R_1 is the unknown reaction at the left support, and x is the distance of any section from that support. Inserting this in the differential equation (45) and integrating, the constant of integration is found by the condition that $\delta y/\delta x = 0$ when $x = l$. Integrating again, the constant is found by the condition that $y = 0$ when $x = 0$, and,

$$24EIy = 4R_1x^3 - 12R_1l^2x + 4wl^3x - wx^4$$

is the equation of the elastic curve. In this y becomes h when x becomes l , and accordingly the left reaction is,

$$R = \frac{3}{8}wl - (3EI/l^3)h$$

This shows that the value of R depends upon the difference of level of the two supports. When $h = 0$, the case is the same

as Case I in Art. 60 and $R_1 = \frac{3}{8}wl$; when h is positive, or the fixed end higher than the supported one, R_1 is less than $\frac{3}{8}wl$; when h is negative, or the fixed end lower than the supported one, R_1 is greater than $\frac{3}{8}wl$. The formula also shows that the value of R_1 depends upon the kind of material of the beam, since E is the modulus of elasticity of the material, and upon the size and shape of its cross-section, since these are included in the moment of inertia I .

Let Fig. 64c represent a beam with both ends fixed, and let h be the vertical height of the right above the left end. Under a uniform load let the unknown reaction at the left support be R_1 and the unknown moment be M_1 . Then the differential equation of the elastic curve for an origin at the left support is, as in Art. 62,

$$EI \frac{\delta^2 y}{\delta x^2} = M_1 + R_1 x - \frac{1}{2} wx^2$$

Integrating this twice, and introducing sufficient conditions to determine the constants and the values of R_1 and M_1 , there result,

$$R_1 = \frac{1}{2}wl + (12EI/l^3)h \quad M_1 = -\frac{1}{2}wl^2 + (6EI/l^2)h$$

and accordingly these values depend not only upon the difference in level of the supports but also upon the dimensions and kind of material of the beam. When $h=0$, the values of R_1 and M_1 are the same as those deduced in Art. 62. The reaction R_2 at the right end of the beam is $wl - R_1$ and the moment there is found from $M_2 = M_1 + R_1 l - \frac{1}{2}wl^2$; accordingly,

$$R_2 = \frac{1}{2}wl + (12EI/l^3)h \quad M_2 = -\frac{1}{2}wl^2 - (6EI/l^2)h$$

which show that at the higher end of the beam the reaction is always positive and the moment always negative, while at the other end they may be positive or negative depending on the value of h .

Not only the reactions and moments at the supports but also the shears and moments throughout the beam undergo change when one support is lowered below the other. To ascertain the magnitude of these changes, take a 10-inch I beam of structural steel which weighs 25 pounds per linear foot, for which $E=30\,000\,000$ pounds per square inch and $I=122.1$ inches⁴

(Table 6). Let one end be supported and the other fixed, as in Fig. 64*b* the clear span be 15 feet and the total uniform load W be 16 400 pounds. When both supports are on the same level, the left reaction is $\frac{3}{8}W = 6\ 150$ pounds, and the maximum moment is $\frac{1}{8}Wl = 30\ 750$ pound-feet = 369 000 pound-inches; then the flexure formula gives $S = 369\ 000/24.42 = 15\ 100$ pounds per square inch, which is a satisfactory unit-stress for steady load. Now let the left support be lowered 1.2 inches below the fixed end; the reaction at that end is then less than 6 150 pounds by the amount $3EIh/l^3 = 3 \times 30\ 000\ 000 \times 122.1 \times 1.2/180^3 = 2\ 260$ pounds, so that it is $R_1 = 6\ 150 - 2\ 260 = 3\ 890$ pounds. From this the moment at the fixed end is found to be $M = R_1l - \frac{1}{2}Wl = 775\ 800$ pound-inches, and the flexure formula then gives $S = 31\ 800$ pounds per square inch, which is too high a value for safety as it is but little less than the elastic limit of the material.

The conclusion of this investigation is that beams with one or both ends fixed should not be used in circumstances where any material alteration in the levels of the supports may occur. The above formulas show that when the left support in Fig. 64*b* is lowered the distance $h = Wl^3/8EI$ below the level of the other, the left reaction under uniform load is zero and the beam is a cantilever fixed at the right end. The same condition obtains for the beam in Fig. 64*c* when it is uniformly loaded and the left end is lowered the distance $Wl^3/24EI$; when greater depressions occur, the left reaction is negative and the beams are in the condition of constrained cantilevers uniformly loaded and having a concentrated load at the free end (Art. 65). It should also be noted that the moments and reactions deduced above are only valid when the elastic limit of the materials is not exceeded.

Prob. 64*a*. For the case of Fig. 64*c*, deduce expressions for the distance of the inflection points from the left support.

Prob. 64*b*. A wooden joist, $3 \times 12 \times 75$ inches, is fixed in walls at its ends and carries a total uniform load of 7 680 pounds. Compute the maximum unit-stress S when the supports are on the same level; also when one support is lowered one-quarter of an inch below the other.

ART. 65. CANTILEVER WITH CONSTRAINT

A case which occurs in the portal of a bridge is shown in Fig. 65a, where AC and ac represent the two end posts connected by bracing which transfers the wind pressures P to the points B and b . The parts BC and bc of these posts are cantilever beams fixed at the lower ends C and c , while they are also kept fixed at B and b by the restraint of the portal bracing. By turning this figure clockwise through a right angle, it will be in the position of the end view of a bridge portal.

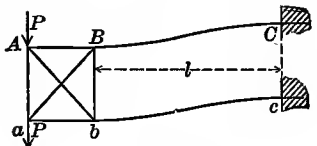

Fig. 65a

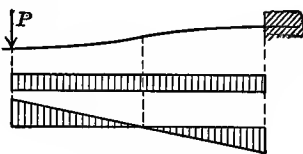

Fig. 65b

To investigate a cantilever beam in which the free end is kept horizontal by a restraint during its deflection, let Fig. 65b be considered. Taking the origin of coordinates at the free end where the unknown moment is M_1 , the differential equation of the elastic curve is $EI \cdot \delta^2 y / \delta x^2 = M_1 - Px$ for any section distant x from that end. Integrating this it becomes $EI \cdot \delta y / \delta x = M_1 x - \frac{1}{2} Px^2$, the constant being zero because the tangent to the elastic curve is horizontal at the left end. At the right end, for which $x = l$, the tangent is also horizontal, and hence $M_1 = +\frac{1}{2} Pl$. The moment at the right end now is $M_2 = +\frac{1}{2} Pl - Pl = -\frac{1}{2} Pl$, the inflection point is at $x = \frac{1}{2} l$, since $M = \frac{1}{2} Pl - Px = 0$ locates this point, and the moment diagram can then be drawn as shown.

It thus appears that the maximum moments for this case is only one-half as large as the common cantilever beam loaded at the end. The deflection of the end may be found by integrating the above first derivative, and it is $f = Pl^3 / 12EI$, which is only one-fourth of that of the common cantilever with a load at the end.

Another case of a cantilever with restraint at the free end is that of a crank-pin connected by two webs through which the torsion of a shaft is transmitted. A figure showing such a

crank-pin may be found in Art. 98, and it is there seen that the bending moments due to the transmitted lateral force from the web are exactly the same as those deduced above.

A cantilever may be fixed in a wall at any angle with the horizontal. In that event, let l be the length of the inclined beam, and let the axis of abscissas be taken as coinciding with the tangent drawn to the elastic curve at the wall; then if the angle of inclination be small the formulas deduced in Art. 54 will approximately give the vertical deflection of the end from that tangent. The bending moment at the wall is found, however, by using the horizontal lever arms of the vertical forces. When the angle of inclination is not small, the cantilever is subject to combined axial stress and flexure (Art. 101).

Prob. 65*a*. Deduce the moments at the supports for Fig. 65*b* without using the equation of the elastic curve.

Prob. 65*b*. A steel crank-pin, like that of Fig. 98, is hollow, 18 inches in outside and 6 inches in inside diameter and 12 inches in length between the webs into which it is fixed. Compute the deflection of one end with respect to the other when the force P is 126 100 pounds.

ART. 66. SPECIAL DISCUSSIONS

When a simple beam deflects the upper side is shortened and the lower side elongated. These changes in length are due to the horizontal compressive and tensile stresses acting along those sides, and the amount of the same will now be found. Let S be the unit-stress acting on the side at the distance c from the neutral surface, and E the modulus of elasticity of the material. Then, from Art. 9, the change of length which occurs in the distance δx is $(S/E)\delta x$, and hence the total change of length in the span l is the sum of all these elementary values; to find this sum S is to be expressed in terms of x , since S varies throughout the span. From the flexure formula (41) the value of S is Mc/I , and for a simple beam under the uniform load w per linear unit M is $\frac{1}{2}wx - \frac{1}{2}wx^2$. Accordingly the entire change of length of the upper or lower surface of the beam is,

$$e = \frac{1}{2}(cw/EI) \int (lx - x^2) dx$$

in which the integration is to be made between the limits l and 0 . This gives $e = wc^3/12EI$ which is the amount of shortening of the upper side of the simple beam if c is the distance of that side from the neutral surface, or the amount of elongation of the lower side of the beam if c is its distance from the neutral surface. For example, let the beam be an unloaded steel bar, $2 \times 2 \times 72$ inches, then the formula gives $e = 0.0000122$ inches.

Steel bars are sometimes used in measuring the base lines of geodetic triangulations. The upper diagram of Fig. 66a shows such a bar laid upon a horizontal plane and the positions of two marks upon its upper surface very near its ends; the distance between these marks is determined with precision by comparisons with a standard. When the bar is used in the field, it is laid upon two supports, as in the lower diagram of Fig. 66a, and these supports should be so placed that the distance between the marks remains unaltered by the deflection of the beam under its own weight. In this beam with equal overhanging ends, the upper fibers are shortened between the two inflection points and elongated elsewhere; hence it is possible to place the supports at such a distance apart that the amounts of shortening and elongation are equal and then the distance between the two marks will be unaltered by the bending of the beam.

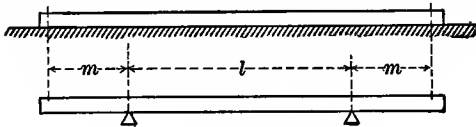

Fig. 66a

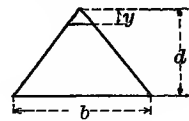

Fig. 66b

Let L be the length of the beam, which is practically equal to the distance between the two marks, m the length of each overhanging end, and l the distance between the supports; thus $2m + l = L$, and if the ratio of l to m is found, that of m to L will be known. Let x be any distance from the left end, then the elongation of any upper fiber on the overhanging end in the distance δx is $(S/E)\delta x$, which by the flexure formula becomes $(Mc/EI)\delta x$ or $(wc/2EI)x^2\delta x$. Integrating this between the limits m and 0 , there results $e_1 = wcm^3/6EI$ for the elongation

of the upper fiber of the overhanging end. Again, the moment M at a section in the central span distant x from the left support is $R_1x - \frac{1}{2}w(m+x)^2$, in which R_1 is the reaction $wm + \frac{1}{2}wl$. It hence follows that,

$$e_2 = \frac{1}{2}(wc/EI) \int (lx - x^2 - m^2) \delta x$$

is the shortening of the upper fiber in the central span; when this is integrated between the limits l and 0 it gives $e_2 = (wc/12EI)(l^3 - 6m^2l)$. Now the condition that there shall be no change of length in the upper fiber is $e_2 - 2e_1 = 0$, which leads to the cubic equation $l^3 - 6m^2l - 4m^3 = 0$. This equation gives $l/m = 2.732$ and the two other roots are negative. Hence $m = 0.2113L$ and $l = 0.5774L$, so that, if the length of the bar is one meter, the distances l and m should be 577.4 and 211.3 millimeters.

Beams of triangular section are rarely or never used in practice, since, if the vertex be upward the load cannot safely rest on the sharp edge, and if the vertex be downward it cannot safely rest on the supports. If b is the base and d the altitude, as in Fig. 66*b*, the section factor I/c is, from Arts. 42 and 43, found to be $\frac{1}{4}bd^2$ and hence, from Art. 56, the triangular beam is one-quarter as strong as a rectangular one having the same breadth and depth. If the triangle is cut off at a depth y below the vertex, thus forming a trapezoidal section with the bases b and by/d and the height $d - y$, the section factor with respect to the new neutral axis will be greater than $\frac{1}{4}bd^2$ when the value of y is less than a certain limit. Hence the strength of a triangular section may be increased by cutting off the vertex. This case is one of mere theoretical interest and will not be developed here, but it is shown on page 181 of Wood's *Resistance of Materials* (New York, 1882) that the maximum strength of the trapezoid thus formed is 9 percent greater than the strength of the triangular section and that this occurs when the distance y is 13 percent of the altitude d .

The following are a few interesting problems regarding beams which involve ideas that have not received detailed discussion in the preceding pages.

Prob. 66*a*. Find the thickness of a white-pine plank of 8 feet span so that it shall not bend more than one-fifth of an inch under a head of water of 10 feet.

Prob. 66*b*. Prove that the greatest possible length of a simple beam of breadth b , depth d , for an assigned flexural unit-stress S is $(4Sd/3v)^{\frac{1}{2}}$, where v is the weight of a cubic unit of the material.

Prob. 66*c*. A simple wooden beam, one inch square and 15 inches long, is uniformly loaded with 100 pounds. Find the angle of inclination of the elastic curve at the supports.

Prob. 66*d*. A simple beam of structural steel, one inch in diameter, is of such a length that the flexural unit-stress at the middle, due to its own weight, is equal to the elastic limit. Compute the inclination of the elastic curve at the supports.

Prob. 66*e*. A rolled steel beam, $5\frac{1}{2}$ meters long and 30 centimeters deep (Table 13), is fixed at its ends and carries a uniform load of 2 600 kilograms. Compute the greatest horizontal unit-stress S in kilograms per square centimeter, and ascertain the factor of safety of the beam.

CHAPTER VIII

CONTINUOUS BEAMS

ART. 67. GENERAL PRINCIPLES

A continuous beam is one resting upon several supports, these being usually in the same horizontal plane. A simple beam may be regarded as a particular case of a continuous beam where the number of supports is two. The ends of a continuous beam are said to be free when they overhang, supported when they merely rest on abutments, and fixed when they are kept horizontal by the restraint of walls; the most common cases are those of supported ends and this chapter will be mainly devoted to their discussion.

The general principles of the preceding chapters hold good for all kinds of beams. If a vertical plane is imagined to cut any beam at any point, the laws of Arts. 39 and 40 apply to the stresses in that section. The resisting shear and the resisting moment for that section have the values deduced in Art. 41 and the shear and flexure formulas are,

$$S_s a = V \qquad S \cdot I/c = M$$

Here S_s is the vertical shearing unit-stress in the section, and S is the horizontal tensile or compressive unit-stress on the fiber most remote from the neutral surface, c is the shortest distance between that fiber and neutral surface (Art. 42); a is the area of the cross-section and I its moment of inertia with respect to the neutral axis. V is the vertical shear of the external forces on the left of the section, and M is the bending moment of those forces with reference to a point in the section. For any given beam, evidently S_s and S may be found for any section as soon as V and M are known, and these are determined for any given loads from the definitions in Arts. 37 and 38. For brevity V and M will hereafter be called shear and moment.

The general equation of the elastic line, deduced in Art. 45,

is also valid for all kinds of beams. It is $EI\delta^2y/\delta x^2 = M$, where x is the abscissa and y the ordinate of any point of the elastic curve, and E the coefficient of elasticity of the material.

The shear V is the algebraic sum of the external forces on the left of the section, or, as in Art. 37,

$$V = \text{Reactions on left of section minus loads on left of section.}$$

For simple beams and cantilevers the determination of V for any special case was easy, as the left reaction could be readily found for any given loads. For continuous beams, however, it is not, in general, easy to find the reactions, and hence a different method of determining V is usually necessary. Let Fig. 67 represent one span of a continuous beam. Let V be the shear

for any section at the distance x from the left support, and V' the shear at a section infinitely near to the left support. Also let ΣP_1 denote the sum

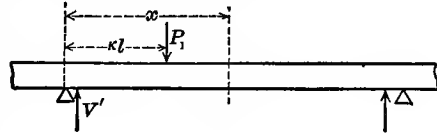

Fig. 67

of all the concentrated loads on the distance x , and wx the uniform load. Then because V' is the algebraic sum of all the vertical forces on its left, the definition of vertical shear gives,

$$V = V' - wx - \Sigma P_1 \quad (67)$$

Hence the shear V can be determined for any section in the span as soon as V' is known.

The moment M is the algebraic sum of the moments of the external forces on the left of the section with reference to a point in that section, or, as in Art. 38,

$$M = \text{moments of reactions minus moments of loads}$$

For the reason just mentioned, it is in general necessary to determine M for continuous beams by a different method. Let M' denote the moment at the left support of any span as in Fig. 67, and M'' that at the right support, while M is the moment for any section distant x from the left support. Let P_1 be any concentrated load upon the space x at a distance κl from the left support, κ being a fraction less than unity, and let w be the uniform load per linear unit. Since the shear V' in Fig. 67 is equal to

the resultant of all the vertical forces on the left of a section just at the right of the left support, let m be the distance of the line of action of that resultant to the left of that support. Then the definition gives, for the moment at any section,

$$M = V'(m+x) - wx \cdot \frac{1}{2}x - \Sigma \cdot P_1(x-\kappa l)$$

But the quantity $V'm$ is equal to the sum of the moments of all the forces on the left of the left support with respect to that support and hence it is the moment M' at the left support of the span. Hence,

$$M = M' + V'x - \frac{1}{2}wx^2 - \Sigma \cdot P_1(x-\kappa l) \quad (67)'$$

from which the moment M may be found for any section in the span as soon as M' and V' are known.

The shear V' at the support of the span may be easily found if the moments M' and M'' be known. Thus in equation (67)' make $x=l$, then M becomes M'' , and hence,

$$V'l = M'' - M' + \frac{1}{2}wl^2 + \Sigma P_1(l-\kappa l) \quad (67)''$$

and hence the problem of the discussion of continuous beams consists in the determination of the moments at the supports. When these are known, the values of M and V may be determined for every section in any span, and the investigation of questions of strength and deflection be made from the formulas (41)^r and (45). The above formulas apply to cantilever and simple beams also. For a simple beam, $M' = M'' = 0$, and $V' = R$. For a cantilever beam, $M' = 0$ for the free end, and M'' is the moment at the wall.

The relation between the moment and the shear at any section is interesting and important. At a section distant x from any support, the moment is M and the shear is V . At the section distant $x+\delta x$ from the support, the moment is $M+V\delta x$, which may also be expressed as $M+\delta M$. Accordingly,

$$V\delta x = \delta M \quad \text{or} \quad \delta M / \delta x = V$$

This may also be found by finding the derivative of M with respect to x from (67)' and comparing it with (67). Therefore

The derivative of the moment equals the shear

and from this it is seen that the maximum moments occur at the sections where the shear passes through zero.

Prob. 67. A bar of length $2l$, and weighing w per linear unit, is supported at the middle. From (67) and (67)' find general expressions for the shear and moment at any section on the left of the support and also at any section on the right of the support. Draw the shear and moment diagrams.

ART. 68. METHOD OF DISCUSSION

The theory of continuous beams presented in the following pages includes only those with constant cross-section having the supports on the same level; since only such are used in engineering constructions. Unless otherwise stated, the ends will be supposed simply to rest upon their supports, so that there can be no moments at those points. Then the end spans are somewhat in the condition of a simple beam with one overhanging end, while the other spans are somewhat in the condition of a beam with two overhanging ends. At each intermediate support there is a negative moment, and the distribution of shears and moments due to uniform load is that shown in Fig. 68. When an end span is short, the reaction at that end may become zero or even be negative; in order that a negative reaction may exist, it is necessary that the end of the beam be anchored or fastened to the support.

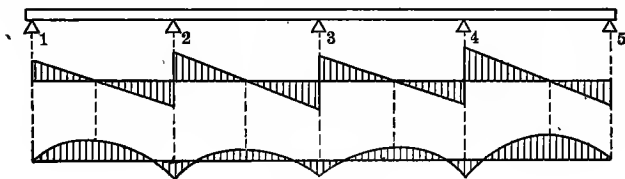

Fig. 68

As shown in Art. 67, the investigation of a continuous beam depends upon the determination of the moments at the supports. In the case of Fig. 68, the moments at the supports 2, 3, and 4, may be designated M_2 , M_3 , and M_4 . Let V_1 , V_2 , V_3 , and V_4 denote the shears at the right of those supports. The first step is to find the moments M_2 , M_3 , and M_4 . Then from formula (67)'' the values of V_1 , V_2 , V_3 , and V_4 are found,

and thus by formula (67)' an expression for the moment in each span may be written, from which the maximum positive moments may be determined. Lastly, by the shear and flexure formulas of Art. 41 the beam may be investigated.

For example, let the beam in Fig. 68 be regarded as of four equal spans and uniformly loaded with w pounds per linear unit. By a method to be explained in the following articles it may be shown that the moments at the supports are,

$$M_2 = -\frac{3}{8}wl^2 \quad M_3 = -\frac{3}{8}wl^2 \quad M_4 = -\frac{3}{8}wl^2$$

From formula (67)'' the shears at the right of the several supports are found to have the values,

$$V_1 = \frac{1}{2}wl \quad V_2 = \frac{1}{2}wl \quad V_3 = \frac{1}{2}wl \quad V_4 = \frac{1}{2}wl$$

And from (67) those on the left of the supports 2, 3, 4, 5, are found to be, $-\frac{1}{2}wl$, $-\frac{3}{8}wl$, $-\frac{1}{2}wl$, $-\frac{1}{8}wl$. From formula (67)' the general expressions for the moments now are,

$$\begin{aligned} \text{for first span,} \quad M &= +\frac{1}{8}wlx - \frac{1}{2}wx^2 \\ \text{for second span,} \quad M &= -\frac{3}{8}wl^2 + \frac{1}{2}wlx - \frac{1}{2}wx^2 \\ \text{for third span,} \quad M &= -\frac{3}{8}wl^2 + \frac{1}{2}wlx - \frac{1}{2}wx^2 \\ \text{for fourth span,} \quad M &= -\frac{3}{8}wl^2 + \frac{1}{2}wlx - \frac{1}{2}wx^2 \end{aligned}$$

From each of these equations the inflection points may be found by putting $M=0$, and the section of maximum positive moment by putting $\partial M/\partial x=0$. The maximum positive moments are found to have the following values:

$$\frac{1}{16}\frac{1}{8}wl^2 \quad \frac{5}{16}\frac{1}{8}wl^2 \quad \frac{1}{16}\frac{1}{8}wl^2 \quad \text{and} \quad \frac{1}{16}\frac{1}{8}wl^2$$

For any particular case the beam may now be investigated by the use of the shear and moment formulas. It is seen that the greatest moment is that at support 2, and hence this need only be used in the flexure formulas.

The reactions at the supports are readily found from the values of the adjacent shears. Thus, for the above case $R_1 = V_1 = \frac{1}{2}wl$, and $R_2 = \frac{1}{2}wl + \frac{1}{2}wl = \frac{3}{4}wl$. But perhaps a more satisfactory method will be to find them directly from the equation of moments. Thus $R_1l - \frac{1}{2}wl^2 = M_2$, whence $R_1 = \frac{1}{4}wl$. Again $R_1 \times 2l + R_2l - 2wl^2 = M_3$, whence $R_2 = \frac{3}{4}wl$. From the symmetry of the spans and loads, it is plain that $R_5 = R_1$ and $R_4 = R_2$.

The equation of the elastic curve in any span is found by inserting the expression for M in $EI \cdot \delta^2 y / \delta x^2 = M$, and integrating twice. In general, the maximum deflection in any span will be found intermediate in value between those of a simple beam and one fixed at its ends.

Prob. 68. In a continuous beam of three equal spans the negative bending moments at the supports are $\frac{1}{4}wl^2$. Find the inflection point, the maximum positive moments, and the reactions of the supports.

ART. 69. THEOREM OF THREE MOMENTS

Let the figure represent any two adjacent spans of a continuous beam having the lengths l' and l'' and the uniform loads w' and w'' per linear unit. Let M' , M'' , and M''' represent the three unknown moments at the supports. Let V' and V'' be the vertical shears at the right of the first and second supports. Then, for any section distant x from the left support in the first span, the moment is, $M = M' + V'x - \frac{1}{2}wx^2$. Let this be inserted in the general formula of the elastic curve. Integrating twice and determining the constants by the conditions that $y = 0$ when $x = 0$ and also when $x = l'$, the tangent $\delta y / \delta x$ of the angle which the tangent to the elastic curve at any section in the first span makes with the horizontal is found to be given by,

$$24EI(\delta y / \delta x) = 12M'(2x - l') + 4V'(3x^2 - l'^2) - w'(4x^3 - l'^3)$$

Similarly if the origin is taken at the next support, the tangent of inclination at any point in the second span is,

$$24EI(\delta y / \delta x) = 12M''(2x - l'') + 4V''(3x^2 - l''^2) - w''(4x^3 - l''^3)$$

The two curves must have a common tangent at the support where they meet, in order that the beam may be continuous. Hence make $x = l'$ in the first equation and $x = 0$ in the second, and equate the results, giving

$$12M'l' + 8V'l'^2 - 3w'l'^3 = -12M''l'' - 4V''l''^2 + w''l''^3$$

Now let V' and V'' be expressed by means of (67)'' in terms of M' , M'' , and M''' ; then this equation reduces to

$$M'l' + 2M''(l' + l'') + M'''l'' = -\frac{1}{4}w'l'^3 - \frac{1}{4}w''l''^3 \quad (69)$$

which is called the theorem of three moments for continuous

beams under uniform loads. It was first deduced by Clapeyron in 1857 and is hence sometimes called Clapeyron's theorem.

This theorem shows how the moment M'' at any support is connected with moments at the preceding and following supports. When all spans are of the same length l and have the same load w per linear unit, the theorem becomes,

$$M' + 4M'' + M''' = -\frac{1}{2}wl^2 \quad (69)'$$

which applies to the most common cases in practice. It must be noted, however, that these theorems of three moments are only valid when the beam is of constant section area and when all the supports are on the same level, since these conditions have been introduced into the algebraic work by taking I as constant, and by taking γ as zero for all supports.

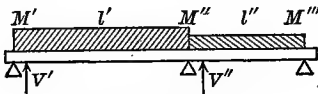

Fig. 69a

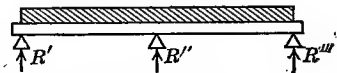

Fig. 69b

In any continuous beam of s spans there are $s+1$ supports and $s-1$ unknown bending moments at the supports. For each of these supports an equation of the form of (69) or (69)' may be written which contains three unknown moments. Thus there will be stated $s-1$ equations, and the solution of these will furnish the values of the $s-1$ unknown quantities.

The simplest case is that shown in Fig. 69b, where there are two equal spans uniformly loaded, the left and right ends of the beam resting upon the supports. Here M' and M''' are each zero, and the theorem (69)' gives $M'' = -\frac{1}{8}wl^2$. The left reaction R' is now found from $R'l - \frac{1}{2}wl^2 = M''$ to be $R' = \frac{3}{8}wl$, and R''' has the same value; hence each span of Fig. 69b is in the same condition as that of a beam fixed at one end and supported at the other.

Prob. 69. A continuous beam of two spans is uniformly loaded with 125 pounds per linear foot. The length of the first span is 18 feet and that of the second span is 12 feet. Compute the moment at the middle support, and the three reactions.

ART. 70. EQUAL SPANS WITH UNIFORM LOAD.

Consider a continuous beam of five equal spans uniformly loaded. Let the supports, beginning on the left, be numbered 1, 2, 3, 4, 5, and 6. From the theorem of three moments an equation may be written for each of the supports at which moments exist; thus,

$$\begin{aligned} \text{for support 2,} & \quad M_1 + 4M_2 + M_3 = -\frac{1}{2}wl^2 \\ \text{for support 3,} & \quad M_2 + 4M_3 + M_4 = -\frac{1}{2}wl^2 \\ \text{for support 4,} & \quad M_3 + 4M_4 + M_5 = -\frac{1}{2}wl^2 \\ \text{for support 5,} & \quad M_4 + 4M_5 + M_6 = -\frac{1}{2}wl^2 \end{aligned}$$

Since the ends of the beam rest on abutments without restraint $M_1 = M_6 = 0$. Hence the four equations furnish the means of finding the four moments M_2, M_3, M_4, M_5 . The solution may be abridged by the fact that $M_2 = M_5$, and $M_3 = M_4$, which is evident from the symmetry of the beam. Hence,

$$M_2 = M_5 = -\frac{4}{3^3}wl^2 \quad M_3 = M_4 = -\frac{8}{3^3}wl^2$$

From formula (67)'' the shears at the right of the supports are,

$$V_1 = \frac{1}{3}wl \quad V_2 = \frac{2}{3}wl \quad V_3 = \frac{1}{3}wl \text{ etc.}$$

From (67)' the moment for any section in any span may now be found as in Art. 68, and by the methods there indicated the complete investigation of any special case may be effected.

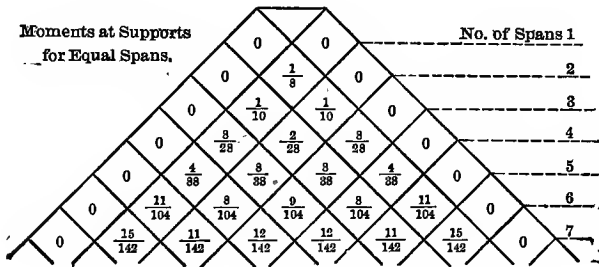

Fig. 70a

In this way the moments at the supports for any number of equal spans can be deduced. The following triangular table shows their values for spans as high as seven in number. In

each horizontal line the supports are represented by squares in which are placed the coefficients of $-wl^2$. For example, in a beam of 3 spans there are four supports, and the bending moments at those supports are 0, $-\frac{1}{10}wl^2$, $-\frac{4}{10}wl^2$, and 0.

The shears at the supports are also shown in the following table for any number of spans less than six. The space representing a support gives the shear on the left of the support in its left-hand division and the shear on the right of the support in its right-hand division. The sum of the two shears for any support is, of course, the reaction of that support. For example, in a beam of five equal spans the reaction at the second support is $\frac{43}{88}wl$.

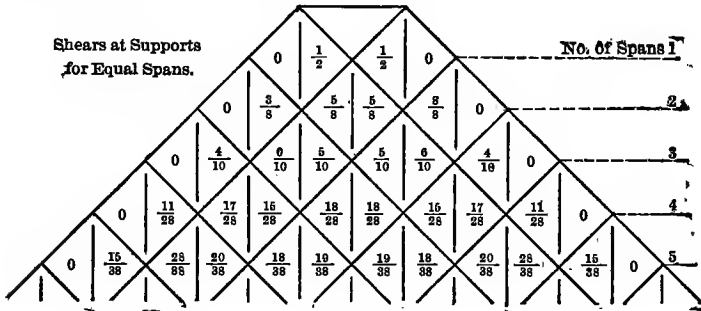

Fig. 70b

It will be seen on examination that the numbers in any oblique column of these tables follow a certain law of increase by which it is possible to extend them, if desired, to a greater number of spans than are here given.

As an example, let it be required to select a rolled steel I beam to span four openings of 8 feet each, the load per span being 44 000 pounds and the greatest horizontal stress in any fiber to be 15 000 pounds per square inch. The required beam must satisfy the flexure formula $S \cdot I/c = M$, or it must be of such size that $I/c = M/15\ 000$. From the table it is seen that the greatest negative moment is that at the second support or $\frac{3}{8}wl^2$, and the maximum positive moment in the first span is $V_1^2/2w = \frac{121}{1568}wl^2$ and that in the second span is $M_2 + V_2^2/2w = \frac{57}{1568}wl^2$.

The greatest value of M is hence at the second support; then,

$$I/c = 3 \times 44\,000 \times 8 \times 12 / 28 \times 15\,000 = 30.2 \text{ inches}^3$$

and from Table 6 it is seen that the light 12-inch beam, for which I/c is 36.0, will most closely satisfy the requirements.

Prob. 70a. Find several shears and moments for three equal spans uniformly loaded, and draw the shear and moment diagrams.

Prob. 70b. Select the proper steel I beam to span three openings of 12 feet each, the uniform load on each span being 600 pounds and the greatest value of S to be 1200 pounds per square inch.

ART. 71. UNEQUAL SPANS AND LOADS

As the first example, consider two spans with lengths l_1 , l_2 , and uniform loads per linear unit w_1 and w_2 . The theorem of three moments in (69) then reduces to,

$$2M_2(l_1 + l_2) = -\frac{1}{4}w_1l_1^3 - \frac{1}{4}w_2l_2^3$$

from which the bending moment at the middle support is known. When there is no load upon the second span w_2 is zero. As a particular case let $l_1 = 40$ and $l_2 = 30$ feet, $w_1 = 210$ pounds per linear foot and $w_2 = 0$; then $M_2 = -24\,000$ pound-feet. The reaction R_1 is found from $R_1 \times 40 - \frac{1}{2} \times 210 \times 40^2 = M_2$, which gives $R_1 = +3600$ pounds. The reaction R_3 is found from $R_3 \times 30 = M_2$, which gives $R_3 = -800$ pounds. The shear passes through zero in the first span at the point for which $R_1 - wx = 0$, which gives $x = R_1/w$, and the maximum positive moment is then $M = R_1^2/2w = 30\,900$ pound-feet. From these values the shear and moment diagrams in Fig. 71a are constructed.

Next consider three spans having the lengths l_1 , l_2 , and l_3 , and loaded uniformly with w_1 , w_2 , w_3 . The moments at the second and third supports are M_2 and M_3 . Then from (69),

$$2M_2(l_1 + l_2) + M_3l_2 = -\frac{1}{4}w_1l_1^3 - \frac{1}{4}w_2l_2^3$$

$$M_2l_2 + 2M_3(l_2 + l_3) = -\frac{1}{4}w_2l_2^3 - \frac{1}{4}w_3l_3^3$$

and the solution of these gives the values of M_2 and M_3 . A very common case for swing drawbridges is that where two end spans are equal and the load uniform throughout, or $l_2 = l$, $l_1 = l_3 =$

αl , and $w_1 = w_2 = w_3 = w$. For this case the solution gives,

$$M_2 = -\frac{1}{4}(1 + \alpha^3)wl^2 / (3 + 2\alpha)$$

For example take a swing-bridge where the two end spans are each 120 feet and the middle span is 24 feet, this being a continuous girder when closed. Here $\alpha = 120/24 = 5$, and $M_2 = -2.423wl^2$, which is the moment at supports 2 and 3 due to live load over all spans. When live load covers only the first span w_2 may be made zero, and the moments be found by the solution of the above equations. In Part IV of Roofs and Bridges these cases of loading are fully discussed.

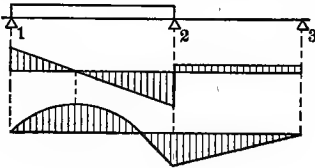

Fig. 71a

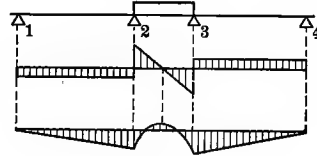

Fig. 71b

Whatever be the lengths of the spans or the intensity of the uniform loads, the theorems of three moments in Art. 69 furnish the means of finding the bending moments at the supports. Then by the methods of Art. 67 shears and moments at every section may be computed and the degree of security of the beam be investigated by the flexure formula (41). Finally, if the material is not stressed beyond its elastic limit, formula (45) may be used to determine the deflection.

Prob. 71a. A continuous beam of three spans is loaded only in the middle span, as in Fig. 71b. Find the reactions of the end supports due to this load.

Prob. 71b. A heavy 12-inch steel I beam of 36 feet length covers four openings, the two end ones being each 8 feet and the others each 10 feet in span. Find the maximum moment in the beam. Then determine the load per linear foot so that the greatest horizontal unit-stress may be 15 000 pounds per square inch.

Prob. 71c. For the case of three spans let the first and third spans be each 80 feet long. Find the length of the middle span so that the moment shall be zero at the middle of that span, the load being uniform throughout.

ART. 72. SPANS WITH FIXED ENDS

The theorem of three moments may also be used to determine the bending moments at the supports when the ends of the continuous beam are horizontally fixed in walls. If the number of spans be two, there are three unknown moments and hence three equations are to be written for four spans; in these the lengths of the first and last spans are to be made zero and thus the elastic curve will be made horizontal at the ends of the beam. The following example will illustrate the procedure.

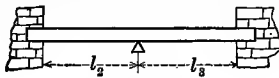

Fig. 72a

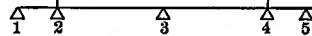

Fig. 72b

Let there be two spans of lengths l_2 and l_3 with ends horizontally fixed, as in Fig. 72a. In Fig. 72b let the restraint of the walls be replaced by the span l_1 on the left end and the span l_4 on the right end, these spans being taken as unloaded. From (69) the equations for the three supports 2, 3, 4, are,

$$\begin{aligned} \text{for support 2,} \quad & M_1 l_1 + 2M_2(l_1 + l_2) + M_3 l_2 = -\frac{1}{4} w_2 l_2^3 \\ \text{for support 3,} \quad & M_2 l_2 + 2M_3(l_2 + l_3) + M_4 l_3 = -\frac{1}{4} w_2 l_2^3 - \frac{1}{4} w_3 l_3^3 \\ \text{for support 4,} \quad & M_3 l_3 + 2M_4(l_3 + l_4) + M_5 l_4 = -\frac{1}{4} w_3 l_3^3 \end{aligned}$$

Now, M_1 and M_5 are zero since the ends are supposed to merely rest on the supports 1 and 5. By making $l_1 = 0$ the points 1 and 2 become consecutive, which renders the elastic curve horizontal at 2; also by making $l_4 = 0$ the points 4 and 5 become consecutive which renders the elastic curve horizontal at 4. As a special case let $l_2 = l_3 = l$ and $w_2 = w_3 = w$, so that the two spans are equal and have the same uniform load; then from symmetry it is known that M_4 is equal to M_2 , so that the equations become,

$$2M_2 + M_3 = -\frac{1}{4} w l^2 \qquad 2M_2 + 4M_3 = -\frac{1}{2} w l^2$$

from which are found $M_2 = -\frac{1}{12} w l^2$ and $M_3 = -\frac{1}{12} w l^2$. As another special case let the two spans be equal and the uniform load be only on the first span or $w_2 = w$ and $w_3 = 0$; then the equations are,

$$2M_2 + M_3 = -\frac{1}{4} w l^2 \qquad M_2 + 4M_3 + M_4 = -\frac{1}{4} w l^2 \qquad M_3 + 2M_4 = 0$$

from which the moment at the left fixed end is $M_2 = -\frac{5}{48}wl^2$ that at the middle support is $M_3 = -\frac{1}{24}wl^2$, and that at the right fixed end is $M_4 = +\frac{1}{8}wl^2$.

The fixing of the ends renders the bending moments smaller than those of beams with supported ends and hence causes an increase of strength, while the stiffness is also made greater. Continuous beams in the floors of buildings often have their ends fixed in walls. When the spans are two in number and of equal length, each span is in the same condition, under uniform load, as one with both ends fixed, since the elastic curve is horizontal over the middle support.

Prob. 72a. Draw the shear and moment diagrams for a beam of two equal spans with fixed ends, the first span being unloaded and the second covered with uniform load.

Prob. 72b. Using the theorem of three moments for concentrated loads given in the next article, deduce the moments for Fig. 72a caused by a load P at the middle of the first span.

ART. 73. CONCENTRATED LOADS

Thus far only uniform loads upon one or more spans have been discussed, but all the methods given are applicable to concentrated loads, provided the moments at the supports due to those loads can be found. By a process of reasoning similar to that in Art. 69, a theorem of three moments for such loads can be deduced, and it will here be stated without the algebraic work of demonstration. As before the beam is to be of constant section throughout its length and all supports are to be upon the same level.

Let l' and l'' be the lengths of any two consecutive spans and M' , M'' , and M''' the moments at the three supports. Let P' be any load upon the first span at the distance $\kappa l'$ from the first support, and P'' any load upon the second span at the distance $\kappa l''$ from the second support, κ being any fraction less than unity and not necessarily the same for the two loads. Then the theorem of three moments is,

$$M'l' + 2M''(l' + l'') + M'''l'' = -P'l'^2(\kappa - \kappa^3) - P''l''^2(2\kappa - 3\kappa^2 + \kappa^3)$$

which is to be used in the same manner as those of Art. 69. If there is no load on the span l' , then P' is zero; if there is none on the span l'' , then P'' is zero.

To illustrate the application of this formula, let there be two equal continuous spans, as in Fig. 73a, with a load P on the first span. Here P' becomes P and P'' is zero, and since there are no moments at the ends, the theorem gives $M_2 = -\frac{1}{4}Pl(\kappa - \kappa^3)$. To find the left reaction, $R_1l - P(l - \kappa l) = M_2$ from which $R_1 = \frac{1}{4}P(4 - 5\kappa + \kappa^3)$. When the load is at the middle of the span, κ is $\frac{1}{2}$, and $M_2 = -\frac{3}{32}Pl$ and $R_1 = \frac{1}{8}\frac{3}{2}P$. The reaction at the right end is found from $R_3l = M_2$, whence $R_3 = -\frac{1}{4}P(\kappa - \kappa^3)$ or $R_3 = -\frac{3}{32}P$; hence the right end must be prevented from rising from the support in order that this negative reaction can prevail. If that end is not fastened, R_3 is zero and the reaction R_1 is $P(1 - \kappa)$ as for a simple beam.

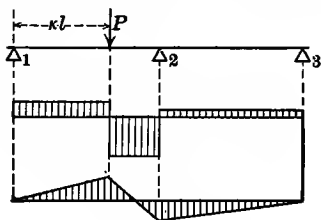

Fig. 73a

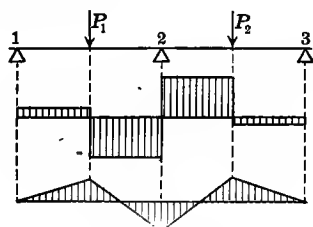

Fig. 73b

From the above results and from the definitions of shear and moment in Arts. 37 and 38, the shear and moment diagrams may be drawn, as in Fig. 73a. The inflection point is found from $R_1x - P(x - \kappa l) = 0$, whence its position is given by $x = 4l/(5 - \kappa^2)$; when $\kappa = 1$ the load is at the middle support and $x = l$; when $\kappa = 0$ the load is at the left support and $x = \frac{4}{5}l$. Hence the inflection point for a load in the first span always lies on the last fifth of the span.

When there are loads on both spans, as in Fig. 73b, the moments due to both may be found from the theorem, or the moments and reactions due to each may be separately determined and the final moment found by addition. Thus, if each load is at the middle of the span, the reaction R_1 due to P_2 is known from

the value of the reaction R_3 due to P_1 ; hence for both loads $R_1 = \frac{1}{3}P_1 - \frac{2}{3}P_2$, so that, if P_1 and P_2 are equal R_1 is $+\frac{1}{6}P$.

The theorem of three moments above given was deduced in 1865 by Bresse, and from it the theorem of Clapeyron (Art. 69) for uniform loads is readily derived. Let w' be the load per linear unit on the first span and P' be a small part of this uniform load extending over the distance $\delta(\kappa l)$, then P' is to be replaced by $w\delta(\kappa l)$ and $P'l^2(\kappa - \kappa^3)$ becomes $w'l^3(\kappa - \kappa^3)\delta\kappa$. Integrating this between the limits 1 and 0, the uniform load covers the whole span and the function is $\frac{1}{4}w'l^3$ as in Clapeyron's theorem.

An abbreviated method of finding the moments at the supports, without writing the theorem of three moments for each support, was devised by the author in 1875. See London Philosophical Magazine, September, 1875; or Roofs and Bridges, Part IV. This method can also be directly applied to cases where one or both ends are fixed. Continuous beams with fixed ends are, however, rarely used under the action of a live load.

Prob. 73. A continuous beam has four spans of 6, 8, 8, 6 feet length; the ends resting upon abutments. Find the left reaction due to a load of 1 000 pounds at the middle of the second span.

ART. 74. SUPPORTS ON DIFFERENT LEVELS

All cases of flexure thus far considered have been for supports on the same level, except that of fixed beams in Art. 64. The general remarks there given regarding the effect of changes of level of the supports apply also to continuous beams. Indeed a slight depression of one support below the level of the others may cause great changes in the moments and stresses throughout the beam.

Let Fig. 74*a* represent two consecutive spans of a continuous beam having the lengths l' and l'' ; let the axis of abscissas be horizontal, h' , h'' , and h''' being the heights of the three supports above this axis. Let the beam be anchored to the supports so that its lower surface is compelled to touch them under all circumstances. This constraint produces moments at the

supports, the magnitude of which will depend upon the size and shape of the beam, represented by the moment of inertia I , and upon the stiffness of its material, represented by the modulus of elasticity E .

By proceeding as in Art. 69 a theorem of three moments for this case may be deduced. In the first span, $y = h'$ when $x = 0$ and $y = h''$ when $x = l'$. The value of $\delta y / \delta x$ for the first and second spans hence differs from those of Art. 69 in containing the quantities h' , h'' , h''' . By equating the values of $\delta y / \delta x$ for the middle support, there will be found,

$$M'l' + 2M''(l' + l'') + M'''l'' = -\frac{1}{2}wl'^3 - \frac{1}{2}w''l''^3 - 6EI \left(\frac{h'' - h'}{l'} + \frac{h'' - h'''}{l''} \right)$$

which is the theorem of three moments for uniform load and supports on different levels. This may be extended to include concentrated loads by inserting the functions of P and κ given in the last article.

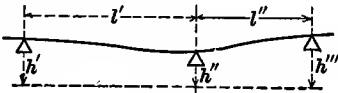

Fig. 74a

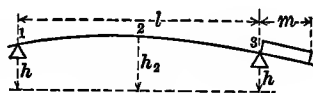

Fig. 74b

To show the method of application of this theorem, take two equal continuous spans with supported ends, and let the middle support be lowered the distance f below the level of the other supports. Then $l' = l'' = l$ and $M' = M''' = 0$, also $h'' - h' = h' - h''' = -f$. Let the load be uniform throughout, so that $w' = w'' = w$. Then there results,

$$M'' = -\frac{1}{8}wl^2 + 3EI f / l^2$$

which shows that the negative bending moment at the middle support is decreased by the circumstance of its depression. When f has the value $wl^2 / 24EI$, there is no moment at this support and each span is like a simple beam. When f has a greater value, the moment becomes positive. If the beam be one of rolled steel weighing 40 pounds per foot and the spans be 16 feet long, the moment at the support due to the weight of the

beam is $-\frac{1}{3}wl^2 = -1\ 280$ pound-feet. Now let the middle support be depressed $.01$ inches below the level of the others; then since $I = 158.7$ inches⁴ from Table 6, the moment due to that depression is $3EI\delta/l^2 = +3\ 230$ pound-feet, so that this slight depression entirely changes the character of the stresses throughout the beam.

Continuous bridges are subject to all the uncertainties of continuous beams in regard to the effect of changes of level of the supports, and hence their use has been almost entirely abandoned. Continuous beams are used only for short spans as is the case with railroad rails, and in floors where there is little liability to change in level of supports.

In conclusion it may be noted that the above theorem of three moments furnishes a very convenient method for finding the elastic deflections of beams. As an example, take the case shown in Fig. 74*b*, where it is desired to find the upward deflection at the middle of the span l due to a uniform load w on the overhanging end m . Let the middle point be marked 2 and the supports 1 and 3; the moments at these points are $M_1 = 0$, $M_2 = -\frac{1}{4}wm^2$, $M_3 = -\frac{1}{2}wm^2$. These are to be inserted in the formula in place of M' , M'' , M''' ; also $l' = \frac{1}{2}l$, $l'' = \frac{1}{2}l$, and $w' = w'' = 0$ since there is no load on the span considered. Also making $h' = h'' = h$, the deflection is $h_2 - h_1$ and the formula now gives its value as $wm^2l/32EI$.

Prob. 74*a*. A continuous beam of two equal spans, uniformly loaded, has its supported ends on the same level. How far must the middle support be depressed so that the negative moment over it may be numerically equal to the maximum positive moment in each span?

Prob. 74*b*. Find, by the above method, upward deflection of the overhanging end in Fig. 74*b*, due to a uniform load over the span l .

ART. 75. THE THEORY OF FLEXURE

The theory of flexure, presented in this and the preceding chapters, is called the common theory, and is the one universally adopted for the practical investigation of beams. It should not be forgotten, however, that the axioms and laws upon which

it is founded are only approximate and not of an exact nature like those of mathematics. The law regarding the proportionality of stress and deformation is, for instance, only roughly approximate for brittle materials. The flexure formula $S \cdot I/c = M$ has been established from this law and from the observed fact that a vertical line, drawn upon the side of the beam before flexure, remains a straight line after flexure.

When the load on a beam is sufficient to cause its rupture, and the longitudinal unit-stress S is computed from the flexure formula, a disagreement of that value with those found by direct experiments on tension or compression is observed. This is often regarded as an objection to the common theory of flexure, but it is in reality no objection, since the laws upon which the flexure formula is founded are only true provided the elastic limit of the material is not exceeded. Experiments on the deflection of beams furnish, on the other hand, the most satisfactory confirmation of the theory. When the modulus of elasticity E is known by tensile or compressive tests, the formulas for deflection are found to give values closely agreeing with those observed. Indeed so reliable are these formulas that it is not uncommon to use them for the purpose of computing E from experiments on beams. When, however, the elastic limit of the material is exceeded, the computed and observed values fail to agree.

Certain false theories of flexure have been proposed from time to time, the one best known being that in which it is assumed that the moment of the horizontal forces on one side of the neutral axis is equal to the moment of those on the other side. Since the principles of static equilibrium furnish no condition of this kind, the formulas established are, of course, without value.

Although it is unfortunate that the flexure formula does not theoretically apply to the rupture of beams, it is better to use it for such cases in connection with experimental constants (Art. 52) than to employ any formula which disagrees with the fundamental principles of statics. Such is the method in general practice, and on the whole it may be concluded that the common theory of flexure is entirely satisfactory and that it is suffi-

cient for the investigation of most questions relating to the strength and stiffness of beams. For materials like cast-iron and concrete it is possible to deduce formulas, which apply more closely than the common flexure formula, by using a parabola instead of a straight line to represent the variation of the stresses above or below the neutral axis (Art. 52). These formulas include constants which give the relation between stress and deformation, so that each material requires a different flexure formula. Although such formulas are theoretically more correct than (41) for stresses beyond the elastic limit, it does not appear that they give better results for rupture than are obtained by using (41) with the values of S_f found by experiment.

In all the examples thus far discussed, the load applied to the beam is parallel to one of the principal axes of inertia of the cross-section and its resultant coincides with that axis. When this is not the case, the flexure formula (41) must be modified in the manner indicated in Art. 166; such unsymmetric arrangement rarely occurs except in the purlin beams of roof trusses.

The actual internal stresses in beams are far more complex than those considered in the common theory, because the vertical shears combine with the horizontal stresses; discussions of the apparent and true stresses are given in Chapters XI and XV. The influence of shear on the deflection of beams is investigated in Art. 125. All the formulas and methods of the preceding chapters apply only to beams in which the material is the same throughout the section area. When different materials are combined to form a beam, the flexure formula must be modified so as to take into account their different degrees of stiffness, and this will be done in Chapter XII.

The theory of beams arose from the discussions of Galileo in the seventeenth century, but it was not until about 1825 that the flexure formula and the general equation of the elastic curve were established by Navier. Since that time great progress has been made in considering the flexure of beams under impact and in applying the principles of work and energy to their dis-

cussion; some of these investigations will receive attention in future chapters.

Prob. 75*a*. A beam of three spans, the center one being l and the side ones nl , is loaded with P at the middle of each span. Find the value of n so that the reactions at the end may be one-fourth of the other reactions.

Prob. 75*b*. Consult Engineering News, vol. xviii, pp. 309, 352, 404, 443; vol. xix, pp, 11, 28, 48, 84; and vol. xxii, p. 121. Write an essay concerning certain erroneous views regarding the theory of flexure which are there discussed.

Prob. 75*c*. Procure several sticks of good timber, each $\frac{1}{8} \times \frac{3}{8}$ inches, and of lengths about 8, 12, and 16 inches. Devise and conduct experiments to test the following laws: First, the strength of a beam varies directly as its breadth and directly as the square of its depth. Second, the stiffness of a beam is directly as its breadth and directly as the cube of its depth. Third, a beam fixed at the ends is twice as strong and four times as stiff as a simple beam, when both are loaded at the middle.

CHAPTER IX

COLUMNS OR STRUTS

ART. 76. CROSS-SECTIONS OF COLUMNS

When a prism has a length longer than about eight or ten times the least side of its cross-section, it is called a 'column' or 'strut'. When the length of the prism is only four or six times as long as the least side of its cross-section, the case is one of simple compression the constants for which are given in Art. 5. Under simple compression the failure occurs for brittle materials by oblique shearing and for plastic materials by enlargement and cracking (Art. 18). In the case of a column, however, failure is apt to occur by a sidewise bending which causes flexural stresses. The longer the column the greater is the liability to lateral flexure.

Wooden columns are usually square or round, and when of large size they may be built hollow. Cast-iron columns are usually round and hollow. Wrought-iron columns were built prior to 1900 of a great variety of forms, but structural steel has since been almost entirely used. Rolled I beams may be used, but most steel columns are formed by riveting together channels, angles, and plates (Art. 44). Columns are extensively used in buildings and bridges. A piston-rod of a steam-engine, or the parallel rod of a locomotive, is a column when it is under compression. It is clear that a square or round section is preferable to an unsymmetrical one, since then the liability of the column to bend is the same in all directions. For a rectangular section, the plane of flexure will evidently be perpendicular to the longer side of the cross-section, and in general the plane of flexure will be perpendicular to that axis of the cross-section for which the moment of inertia is the least; for Art. 56 shows that the deflection of a beam varies inversely as I . In designing a column it is hence advisable that the cross-

section should be so arranged that the moments of inertia about the two principal rectangular axes should be closely equal.

For example, let it be required to construct a column with two I beams, as in Fig. 76a, the pieces connecting the flanges being small and light so that they add nothing to stiffness or strength. Let the beam be the light 15-inch size weighing 42 pounds per foot; then Table 6 gives $I_1 = 441.7$ for an axis perpendicular to the web and $I_2 = 14.62$ inches⁴ for an axis along the middle line of the web; also the section area $a = 12.48$ square inches. Let it be required to find the distance x between the centers of the webs so that the moments of inertia with respect to axes through the center of gravity of the column section shall be equal. For the axis perpendicular to the webs, $I = 2 \times 441.7$; for the axis parallel to the webs, $I = 2 \times 14.62 + 2 \times 12.48 (\frac{1}{2}x)^2$. Equating these two values and solving for x gives $x = 11.70$ inches.

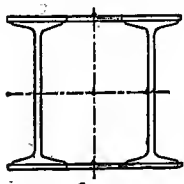

Fig. 76a

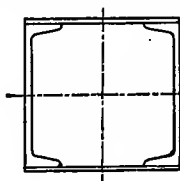

Fig. 76b

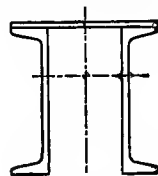

Fig. 76c

As a second example, take the section in Fig. 76b, which is formed by two channels and two plates, the rivets being omitted in the sketch. Each channel is 10 inches deep and weighs 35 pounds per foot, and each plate is x inches long and $\frac{1}{2}$ inch thick. Using Table 9, the moments of inertia of the column section with respect to the two axes through its center of gravity are,

$$I = 2(115.5 + \frac{1}{8}x \times 0.5^3 + 0.5x \times 5.25^2)$$

$$I = 2[4.66 + 10.29(\frac{1}{2}x - 0.70)^2 + \frac{1}{8} \times 0.5x^3]$$

Placing these expressions equal, the value of x is found to be between 10 and 10 $\frac{1}{2}$ inches. This section is suitable only for a column less than 6 feet in length, as the riveting of the plates to the angles could not be done for a long column.

Fig. 76c is a section frequently used for bridge members, there being but one plate connecting the two channels. Here

the center of gravity of the section lies above a line drawn through the middle of the webs and its position is to be found by the method of Art. 42. Then by the principles set forth in Art. 43, the moments of inertia with respect to the two rectangular axes through this center are to be computed, and that which is the smallest is to be used in the column formulas given in the following pages.

Prob. 76a. Two joists, each 2×4 inches, are to be placed 6 inches apart between their centers, and connected by two others, each 8 inches wide and x inches thick, so as to form a hollow rectangular column. Find the proper value of x .

Prob. 76b. Let the section in Fig. 76c consist of a plate, $\frac{5}{8} \times 12$ inches, and two channels, each 12 inches deep and weighing $20\frac{1}{2}$ pounds per linear foot. Compute the moments of inertia with respect to the two axes through the center of gravity.

ART. 77. DEFINITIONS AND PRINCIPLES

When a short prism of section area a is under compression in the direction of its length and the resultant force P acts through the centers of gravity of the end sections, the internal stress is uniformly distributed over the section, and hence the compressive unit-stress S is P/a . For a long prism, or column, this is not always the case, for any sidewise deflection will cause flexural stress which will render the unit-stress on the concave side of the column greater than P/a and that on the convex side less than P/a . Hence for any given column, the load P should be taken smaller for a long one than for a short one, since evidently the liability to bending increases with the length.

The 'Axis' of a column is the line passing through the centers of gravity of the cross-sections. When the column is straight, the axis is a straight line; if it bends laterally, the axis is the elastic curve. An 'axial load' is one having its line of action coinciding with the centers of gravity of the two end sections; the term 'concentric load' is used by some writers for this case. The load P is regarded as axial in the greater part of this chapter this being the most common case in practice.

The length of a column is indicated by l and the least radius of gyration of its cross-section with respect to an axis through the center of gravity of that section by r . The value of r is found from the equation $ar^2 = I$ (Art. 43) where a is the section area and I is the least moment of inertia; for example, if the section is a circle of diameter d , the value of a is $\frac{1}{4}\pi d^2$ and that of I is $\frac{1}{64}\pi d^4$ (Art. 43); hence the radius of gyration of a circular section is $\frac{1}{4}d$. For a rectangle having its least side d and its width b , the radius of gyration is found from $r^2 = \frac{1}{12}bd^3/bd = \frac{1}{12}d^2$ whence $r = 0.289d$. For sections of rolled beams and channels, the values of r for two rectangular axes are given in Tables 6 and 9, and the least of these is the one needed in computations when a beam or channel is to be used as a column.

It was shown in Art. 51, that a given section area a offers greater resistance to flexure the further the material is removed from the neutral axis. When a column bends laterally, flexural stresses similar to those in a beam arise, and hence for columns economy is also promoted by placing the material as far as practicable from the axis about which bending may occur; this is done by making the radius of gyration as large as practicable.

The ratio l/r is called the 'slenderness ratio' of the column. When l/r is less than about 25, the column is a short prism under simple compression (Art. 5); when l/r is greater than about 200 the column is called long and failure occurs by lateral bending. The columns generally used in engineering practice have slenderness ratios varying from 50 to 150.

The condition of the ends of columns exerts a great influence upon their strength. 'Round ends' are those which are free to turn upon the surfaces where they abut; Fig. 77*a* shows one with spherical ends and also one where the compression is applied through pins. 'Fixed ends' are those subject to such restraint that the tangent to the elastic curve remains vertical at the ends when a lateral deflection occurs. Fig. 77*b* shows a column with one end free to turn and the other fixed, and also one with both ends fixed. Columns with both ends fixed are extensively used in buildings and bridges. Columns with one or both ends

hinged on pins are used in bridges and also in machines; the piston-rod of a steam-engine is a case of a column with one end fixed and the other hinged. The term 'round ends' generally includes those which are free to turn on pins at the ends.

It is evident that a column with fixed ends is stronger than one with round ends, and that a column with one end round and the other fixed is intermediate in strength between these; this is confirmed by all experiments. There is also another condition of ends which is called 'flat' and represented in Fig. 77c; here the ends simply abut on plane surfaces without being fixed. The strength of a column with flat ends is closely the same as one with fixed ends when it is short, and about the same as one with hinged ends when it is long.



Fig. 77a



Fig. 77b



Fig. 77c

In the following articles the theory of columns will be developed without considering the weight of the column itself. When a column is in a vertical position, its weight brings a greater unit-stress upon the base than that due to the load (Art. 27), but in most practical cases this increase is small. When a column is in a horizontal position, its weight causes flexure which increases the stress on the upper side due to the direct compression, and this case will be discussed in Arts. 101 and 102.

Prob. 77a. A round cast-iron column has the outer diameter d_1 and the inner diameter d_2 . Find the radius of gyration of the cross-section.

Prob. 77b. An I beam 20 inches deep and weighing 65 pounds per linear foot is used as a column. What length of column will give a slenderness ratio of 220?

ART. 78. EULER'S FORMULA FOR LONG COLUMNS

Consider a long column of section area a , having an axial load P under the action of which a small sidewise bending occurs.

The column is supposed to be perfectly straight before the application of the load, but in practice this condition is not attainable, and the slightest deviation from straightness, or a lack of homogeneity in the material, or even jars and shocks due to surrounding objects, causes bending to occur when the load P is sufficiently large. Even for a perfectly straight column, it is found when P reaches a certain limit and a slight lateral force is applied to cause lateral flexure, that the column remains bent when this lateral force is removed. It is required to find this value of P .



Fig. 78a

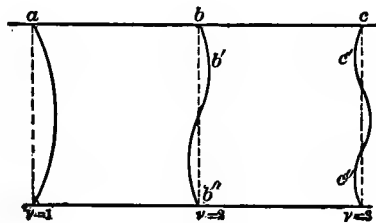

Fig. 78b

Let the column have round ends, as in Fig. 78a, and let l be its length, I the least moment of inertia of its cross-section, and E the modulus of elasticity of the material. Take the origin of coordinates at the upper end, and let x be measured downwards and y horizontal. The general equation (45) is regarded as applicable to all bars subject to flexure, provided the bending is slight and the elastic limit of the material is not exceeded. For the case in hand the bending moment is $M = -Py$; hence $EI \cdot \partial^2 y / \partial x^2 = -Py$, and the integration of this gives,

$$EI \left(\frac{\partial y}{\partial x} \right)^2 = -Py^2 + C$$

To determine C , let f be the maximum deflection at the middle of the column and note that the tangent $\partial y / \partial x = 0$ when $y = f$; hence $C = Pf^2$, and the equation may be written,

$$\frac{\partial x}{\partial y} = (EI/P)^{\frac{1}{2}} (f^2 - y^2)^{-\frac{1}{2}}$$

Integrating this, and determining the constant by the condition that $y = 0$ when $x = 0$, the equation of the elastic curve is,

$$x = (EI/P)^{\frac{1}{2}} \arcsin(y/f) \quad \text{or} \quad y = f \sin(P/EI)^{\frac{1}{2}} x$$

The curve represented by this equation must also fulfill the requirement that $y=0$ when $x=l$. This condition is satisfied by making $(P/EI)^{\frac{1}{2}}l$ equal to π or some integral multiple thereof; for, if ν is any integer, then $\sin \nu\pi = 0$. Accordingly,

$$(P/EI)^{\frac{1}{2}}l = \nu\pi \quad \text{or} \quad P = \nu^2 \pi^2 EI/l^2 \quad (78)$$

which is Euler's formula for long columns. When P has this value, the long column remains bent at any deflection f which may happen to occur. There is no way of finding f from the above investigation since it cancels out of the equation; that is, the deflection is indeterminate.

Inserting the value just found for $(P/EI)^{\frac{1}{2}}$ in the equation of the elastic curve, it reduces to the form,

$$x = (l/\nu\pi) \arcsin(y/f) \quad \text{or} \quad y = f \sin \nu\pi(x/l)$$

By discussing this equation according to the methods of Analytic Geometry there are derived three curves for $\nu=1$, $\nu=2$, and $\nu=3$, as shown in Fig. 78*b*. For $\nu=1$ the curve is entirely on one side of the axis of x ; for $\nu=2$, it crosses that axis at the middle; for $\nu=3$, it crosses at $\frac{1}{3}l$ and $\frac{2}{3}l$. Each of these cases is liable to occur for a column with round ends, but the first is the most dangerous case since the lateral deflection is then the greatest. Hence, making $\nu=1$ in (78), there is found,

$$P = \pi^2 EI/l^2 \quad \text{or} \quad P/a = \pi^2 E(r/l)^2$$

which is Euler's formula for columns with round ends. The second form is obtained from the first by using $I = ar^2$, where r is the least radius of gyration of the cross-section (Art. 77).

A column with one end fixed and the other round is closely represented by the portion $b'b''$ of the second case, b' being the fixed end where the tangent to the curve is vertical. Here $\nu=2$ and the length $b'b''$ is three-fourths of the entire length; hence, replacing l in (78) by $\frac{3}{4}l$ it becomes,

$$P = 2\frac{1}{4}\pi^2 EI/l^2 \quad \text{or} \quad P/a = 2\frac{1}{4}\pi^2 E(r/l)^2$$

which is Euler's formula for long columns having one end fixed and the other end round.

A column with fixed ends is represented by the portion $c'c''$ of the third case. Here $\nu=3$, and the length $c'c''$ is two-thirds of the entire length; hence, replacing l in (78) by $\frac{2}{3}l$,

$$P=4\pi^2 EI/l^2 \quad \text{or} \quad P/a=4\pi^2 E(\gamma/l)^2$$

which is Euler's formula for long columns with fixed ends.

From this investigation it appears that the relative strengths of long columns of the three classes are as the numbers 1, $2\frac{1}{4}$, and 4 when the lengths are the same, and this conclusion is approximately verified by experiments. A general expression for Euler's formula for long columns may now be written, namely,

$$P=\mu EI/l^2 \quad \text{or} \quad P/a=\mu E(\gamma/l)^2 \quad (78)'$$

in which the number μ is π^2 for round ends, $4\pi^2$ for fixed ends, and $2\frac{1}{4}\pi^2$ for one end round and the other end fixed.

Another kind of column is that which is fixed at one end and entirely free at the other, like a vertical post planted in the ground. This case is represented in Fig. 78*b* by the upper half of the case for which $\nu=1$, by the upper fourth of the case for which $\nu=2$, and by the upper sixth of the case for which $\nu=3$. Using either case, and letting l be the length of the column under consideration, there is found,

$$P=\frac{1}{4}\pi^2 EI/l^2 \quad \text{or} \quad P/a=\frac{1}{4}\pi^2 E(\gamma/l)^2$$

and hence the number μ in (78)' is $\frac{1}{4}\pi^2$ for a long column fixed at one end and entirely free at the other. Accordingly a column of this kind can carry only one-fourth of the load of a column with two round ends.

The value of P in Euler's formula gives the axial load which holds the column in equilibrium when it has become laterally deflected. If the load is less than this value of P , the column will return to its original straight position. If the load is slightly greater than P , the bending increases until failure occurs. Euler's formula is hence the criterion of indifferent equilibrium, or the condition for the failure of a column by lateral flexure.

Euler's formula is but little used in engineering computations, except in Germany. When so used the value of P com-

puted from the formula is to be divided by a factor of safety in order to give the safe load on the column. For example, take a rolled steel I beam 15 inches deep which has a least radius of gyration of 1.08 inches; when such a beam is used as a column 24 feet long with fixed ends, the ratio l/r is 267, and approximately $P/a = 4 \times 10 \times 30\,000\,000 / 267^2 = 17\,000$ pounds per square inch. Hence with a factor of safety of 5, this column should be loaded with only about 3 400 pounds per square inch, whereas a short block of the same material might bear $60\,000/5 = 12\,000$ pounds per square inch.

Prob. 78a. A solid steel column with round ends is 6 inches in diameter and 37 feet long. Compute the axial load which will cause it to fail by lateral flexure.

Prob. 78b. A square wooden column with fixed ends is 20 feet long and carries a load of 9 500 pounds. Compute its size so that it may have a factor of safety of 10 by Euler's formula.

ART. 79. EXPERIMENTS ON COLUMNS

Although Euler published his formula in 1757 and Lagrange gave a more satisfactory discussion of it in 1773, it was not until after 1825 that its conclusions began to be used in practical investigations. This formula shows that the load P which causes the failure of a long column is inversely proportional to the square of its length. Hodgkinson in his experiments made about 1840 observed that this was closely true for wrought-iron columns, and only approximately so for cast-iron ones. Since for a solid cylindrical column $I = \frac{1}{64}\pi d^4$, the load P should be proportional to the fourth power of the diameter, and Hodgkinson observed that this ratio was a little too high. He accordingly wrote for each kind of columns the analogous formula $P = Q \cdot d^\alpha / l^\beta$ and determined the constants Q , α , β from the results of his experiments, thus producing empirical formulas.

Let P be the load in gross tons which causes failure, d the diameter of the column in inches, and l its length in feet. Then the empirical formulas deduced by Hodgkinson for solid cylindrical columns are,

$$\begin{array}{l} \text{Cast Iron} \\ \text{Wrought Iron} \end{array} \left\{ \begin{array}{l} P = 14.9d^{3.5}/l^{1.63} \text{ for round ends} \\ P = 44.2d^{3.5}/l^{1.63} \text{ for flat ends} \\ P = 42d^{3.76}/l^2 \text{ for round ends} \\ P = 134d^{3.76}/l^2 \text{ for flat ends} \end{array} \right.$$

These formulas indicate that the ultimate strength of flat-ended columns is about three times that of round-ended ones. The experiments also showed that the strength of a column with one end flat and the other end round is about twice that of one having both ends round. Hodgkinson's tests were made upon small columns and his formulas are not so reliable as those which will be given in the following articles. For small cast-iron columns however the formulas are still valuable. A flat end may sometimes have more or less motion when the deflection begins and hence a flat-ended long column is not as strong as one with fixed ends.

After 1850 wrought iron slowly replaced cast iron as a structural material, and many tests of wrought-iron columns were conducted prior to 1890. The series of tests made by Christie in 1883 for the Pencoyd Iron Works is of great value on account of completeness as regards wrought-iron struts, since it included angle, tee, beam, and channel sections. A brief description and the principal results will here be given, but a fuller account may be found in Transactions of the American Society of Civil Engineers, April, 1884.

The ends of the struts were arranged in different methods: first flat ends between parallel plates to which the specimen was in no way connected; second, fixed ends, or ends rigidly clamped; third, hinged ends, or ends fitted to hemispherical balls and sockets or cylindrical pins; fourth, round ends, or ends fitted to balls resting on flat plates.

The number of experiments was about three hundred, of which about one-third were upon angles, and one-third upon tees. The quality of the wrought iron was about as follows: elastic limit 32 000 pounds per square inch, ultimate tensile strength 49 600 pounds per square inch, ultimate elongation 18 percent in 8 inches. The length of the specimens varied from 6 inches up to 16 feet, and the ratio of length to least radius

of gyration varied from 20 to 480. Each specimen was placed in a Fairbanks testing machine of 50 000 pounds capacity and the power applied by hand through a system of gearing to two rigidly parallel plates between which the specimen was placed in a vertical position. The pressure or load was measured on an ordinary scale beam, pivoted on knife-edges and carrying a moving weight which registered the pressure automatically. At each increment of 5 000 pounds, the lateral deflection of the column was measured. The load was increased until failure occurred.

The following are the combined average results of these carefully conducted experiments. The first column gives the values

Ratio l/r of Length to Least Radius of Gyration	Ultimate Load P/a , in Pounds per Square Inch			
	Fixed Ends	Flat Ends	Hinged Ends	Round Ends
20	46 000	46 000	46 000	44 000
40	40 000	40 000	40 000	36 500
60	36 000	36 000	36 000	30 500
80	32 000	32 000	31 500	25 000
100	30 000	29 800	28 000	20 500
120	28 000	26 300	24 300	16 500
140	25 500	23 500	21 000	12 800
160	23 000	20 000	16 500	9 500
180	20 000	16 800	12 800	7 500
200	17 500	14 500	10 800	6 000
220	15 000	12 700	8 800	5 000
240	13 000	11 200	7 500	4 300
260	11 000	9 800	6 500	3 800
280	10 000	8 500	5 700	3 200
300	9 000	7 200	5 000	2 800
320	8 000	6 000	4 500	2 500
340	7 000	5 100	4 000	2 100
360	6 500	4 300	3 500	1 900
380	5 800	3 500	3 000	1 700
400	5 200	3 000	2 500	1 500
420	4 800	2 500	2 300	1 300
440	4 300	2 200	2 100	
460	3 800	2 000	1 900	
480		1 900	1 800	

of the ratio l/r and the other columns the values of P/a which caused failure, these being the ultimate load in pounds per square

inch. From the results it will be seen that there is little practical difference between the strength of the four classes when the strut is short. The strength of the long columns with round ends appears to be about one-third that of those with fixed ends. For values of l/r greater than 200, the ultimate loads are closely inversely proportional to the squares of the lengths for round ends, and approximately so for other arrangements of ends.

Euler's formula fairly represents the results of the tests on the long columns. Taking $E=25\,000\,000$ pounds per square inch and π^2 as 10, the formula for round-ended columns becomes,

$$P/a = 250\,000\,000(r/l)^2 = 250\,000\,000/(l/r)^2$$

from which the ultimate unit-loads are computed,

$$\begin{array}{cccccc} \text{for } l/r = & 220, & 260, & 300, & 340, & 380, & 420 \\ P/a = & 5200, & 3700, & 2800, & 2200, & 1700, & 1400 \end{array}$$

while the experiments give the ultimate unit-loads as,

$$P/a = 5000, \quad 3800, \quad 2800, \quad 2100, \quad 1700, \quad 1300$$

Since Euler's formula is deduced under the laws of elasticity, it must be concluded that the elastic limit was not exceeded when these long columns failed by lateral flexure.

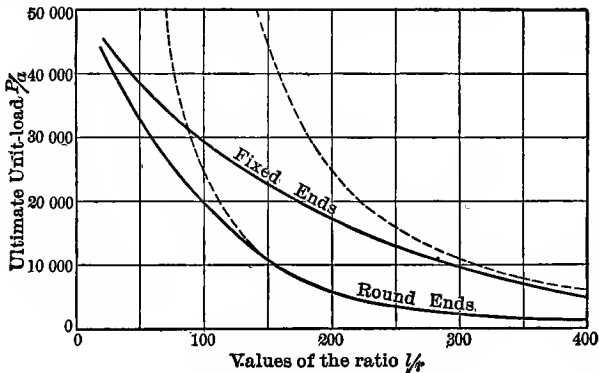

Fig. 79

Fig. 79 gives graphic representations of the above results for the cases of fixed ends and round ends, the values of l/r being taken as abscissas and those of P/a as ordinates. The broken lines also show the curves for these two cases which have been

plotted from Euler's formulas. It is seen that there is a marked disagreement between the experimental results and those found from Euler's formula when l/r is less than 200; this disagreement is due to the circumstance that Euler's formula refers to failure by lateral bending only, while for values less than 200 or 150 the failure actually occurred through the unit-stress on the concave side of the column having exceeded the elastic limit, so that the wrought iron became plastic (Art. 18).

Prob. 79a. A cast-iron cylindrical column with flat ends is to be 7 feet long and carry a load of 200 000 pounds with a factor of safety of 6. Compute the proper diameter.

Prob. 79b. Let Euler's formula be written $y=c/x^2$, where x and y represent l/r and P/a and c is a constant. Discuss this curve and ascertain the points where it is parallel to the coordinate axes.

ART. 80. RANKINE'S FORMULA.

The columns generally employed in engineering practice are intermediate in length between short prisms and the long columns to which Euler's formula applies. They fail under the stresses caused by combined flexure and compression, columns of brittle material by oblique shearing on the concave side or by tension on the convex side, and those of wrought iron and steel by the flow of metal on the concave side after the elastic limit has been surpassed. The ultimate unit-load P/a for these columns is less than the compressive strength S_c for short prisms and very much less than the values computed from Euler's formula, as Fig. 79 shows.

When such a column is perfectly straight, an axial load P produces the same unit-stress $S=P/a$ on all parts of every section area a . When any bending occurs, due to imperfections of the material or to lack of straightness, the unit-stress on the concave side becomes greater than P/a and that on the convex side becomes less. Fig. 80a shows the flexure very much exaggerated; and it is clear that the flexure formula (41) will apply to the discussion of the stresses caused by lateral bending. Let S_1 be the unit-stress produced by the flexure and P/a the average

unit-stress due to the direct compression; then the total unit-stress on the concave side is the sum of P/a and S_1 , and failure may be considered as occurring when this sum is equal to the ultimate compressive strength of the material.

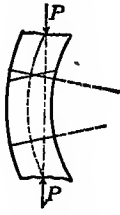

Fig. 80a

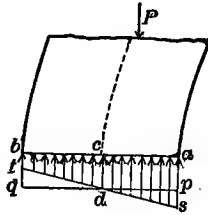

Fig. 80b

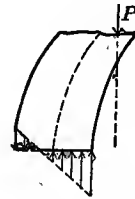

Fig. 80c

Let l be the length of the column, a its section area, I the least moment of inertia, r the least radius of gyration of that section, and c the distance from the axis of the column to the remotest fiber on the concave side. In Fig. 80b, the average compressive unit-stress on any section is represented by cd , but on the concave side this is increased to as and on the convex side decreased to bt . The triangles pds and qdt represent the effect of the flexure exactly as in the case of beams, ps indicating the greatest compressive and qt the greatest tensile unit-stress due to the bending. Let the total maximum unit-stress as be denoted by S and the part due to the flexure be denoted by S_1 . Then $S = P/a + S_1$, in which S_1 is to be expressed in terms of P from the flexure formula $S_1 \cdot I/c = M$, where M is the bending moment due to P . Let f be the maximum lateral deflection of the column; then the greatest value of M is Pf , and accordingly $S_1 = Pcf/I$, or replacing I by ar^2 , the flexural unit-stress $S_1 = P/a \cdot cf/r^2$. Accordingly, the greatest compressive unit-stress on the concave side of the column is,

$$S = \frac{P}{a} + \frac{P}{a} \cdot \frac{cf}{r^2} = \frac{P}{a} \left(1 + \frac{cf}{r^2} \right)$$

By analogy with the theory of beams, as in Art. 56, the deflection f may be regarded as varying directly as l^2/c . Hence, if ϕ is a number depending upon the kind of material and the condition

of the ends of the column, it follows that,

$$S = \frac{P}{a} \left(1 + \phi \left(\frac{l}{r} \right)^2 \right) \quad \text{or} \quad \frac{P}{a} = \frac{S}{1 + \phi(l/r)^2} \quad (80)$$

which is Rankine's formula for the investigation of columns.

The above reasoning has been without reference to the arrangement of the ends of the column. By Art. 78 it is known that a long column with round ends must be one half the length of one with fixed ends in order to be of equal strength, and that a long column with one end fixed and the other round must be three-fourths the length of one with fixed ends in order to be of equal strength. Therefore, assuming that similar laws hold for the shorter columns under consideration, let ϕ_1 be the constant for fixed ends, then the constant for round ends is $4\phi_1$ and the constant for one end round and the other fixed is $\frac{4}{3}\phi_1$.

Values of S and ϕ may be determined by making two experiments on columns having different values of (l/r) and increasing the loads until rupture occurs, thus obtaining different values of P/a . From (80) two equations may be written containing the experimental results and the two unknown quantities S and ϕ , the values of which are then found by solution. Wide variations are found in the results thus obtained for ϕ from experiments on the rupture of different types of columns, but the following table gives average values which are extensively employed in engineering practice:

VALUES OF ϕ FOR FORMULA (80)

Material	Both Ends Fixed	Fixed and Round	Both Ends Round
Timber	$\frac{1}{3\ 000}$	$\frac{1.78}{3\ 000}$	$\frac{4}{3\ 000}$
Cast Iron	$\frac{1}{5\ 000}$	$\frac{1.78}{5\ 000}$	$\frac{4}{5\ 000}$
Wrought Iron	$\frac{1}{36\ 000}$	$\frac{1.78}{36\ 000}$	$\frac{4}{36\ 000}$
Steel	$\frac{1}{25\ 000}$	$\frac{1.78}{25\ 000}$	$\frac{4}{25\ 000}$

These values of ϕ will be used in the examples and problems of the three following articles, and the value to be taken for S will be ultimate compressive strength of the material for cases of rupture and the allowable compressive unit-stress for cases of design.

Euler's formula is not satisfactory for practical investigations because it contains no constant indicating the ultimate or working strength of the material and because it applies only to long columns for which the ratio l/r is greater than about 200. Rankine's formula, however, contains the constant S and applies to cases for which the ratio l/r lies between 20 and about 150, and these are the columns used in engineering practice. On account of the many assumptions employed in deducing it, and because the values of the number ϕ are derived from experiments, the formula is empirical rather than rational, yet it is of very great value. Its form satisfies the limiting conditions for short and long prisms. For a short prism, l/r may be taken as zero, and then $S = P/a$. For a long column, unity may be neglected in comparison with $\phi(l/r)^2$, and then $P/a = Sr^2/l^2\phi$; this is the same in form as Euler's formula, for placing S/ϕ equal to a constant C it becomes $P = Ca \cdot r^2/l^2$. Rankine's formula is sometimes referred to as Gordon's formula, but Gordon used the least thickness of the column instead of the least radius of gyration.

Prob. 80a. Taking values of l/r as abscissas and those of P/a as ordinates, discuss the curve of formula (80) and find where its tangents are horizontal. Also locate its inflection point.

Prob. 80b. Plot the curve represented by formula (80) for wrought-iron columns with fixed ends, taking values of l/r as abscissas and those of P/a as ordinates, and using S as 46 500 pounds per square inch. Compare the plot with Fig. 79.

ART. 81. INVESTIGATION OF COLUMNS

The investigation of a column consists in determining the maximum compressive unit-stress S from formula (80). The values of P , a , l , and r are known from the data of the given case, and ϕ is known from the average experimental

values given in the table of the last article. Then the value of the greatest unit-stress S is computed from,

$$S = \frac{P}{a} \left(1 + \phi \left(\frac{l}{r} \right)^2 \right) \quad (81)$$

By comparing the computed value of S with the ultimate compressive strength and elastic limit of the material, the factor of safety and the degree of stability of the column may be inferred.

For example, consider a hollow wooden column of rectangular section, the outside dimensions being 4×5 inches and the inside dimensions 3×4 inches. Let the length be 18 feet, the ends fixed, and the load be 5400 pounds. Here $P = 5400$, $a = 8$ square inches, $l = 216$ inches, and $\phi = \frac{1}{3000}$. The least radius of gyration is that with respect to an axis parallel to the longer side of the section, and for this axis $r^2 = \frac{1}{12}(5 \times 4^3 - 4 \times 3^3)/8 = 2.21$, and accordingly $l/r = 145$. Substituting now all values in the formula, there is found $S = 5430$ pounds per square inch, so that the factor of safety is only about $1\frac{1}{2}$. The average unit-stress for this case is the same as for a short prism or $S = P/a = 675$ pounds per square inch, which is a safe value since the factor of safety is nearly 12. If the column is 3 feet long, the ratio of slenderness is $l/r = 24$, and the formula gives $S = 805$ pounds per square inch, which corresponds to a factor of safety of 10.

As another example, consider a steel column 21 feet long with fixed ends which is used in the upper chord of a bridge under an axial compression of 240000 pounds. Let the section be that in Fig. 76c, which consists of a plate $\frac{3}{4} \times 16$ inches, and two channels each 12 inches deep and weighing $20\frac{1}{2}$ pounds per linear foot. From the principles of Arts. 42 and 43, with the help of Table 9, the moment of inertia of the section with respect to an axis through its center of gravity and perpendicular to the webs is found to be 501.4 inches⁴ and that with respect to an axis through the center of gravity and parallel to the webs is 663.9 inches⁴. The least radius of gyration then is $r = (501.4/24.06)^{\frac{1}{2}} = 4.56$ inches, and hence the slenderness ratio is $l/r = 55.3$. Using for ϕ the value $\frac{1}{35000}$, the formula now gives $S = 11200$ pounds per square inch, so that the factor of

safety is about 5.3 and the column may be regarded as having a degree of stability a little too low for heavy traffic.

The degree of reliability of values of S computed for columns is very much less than of those computed for beams from the flexure formula (41), since the column formula has a less reliable foundation. Moreover it assumes that the load is truly axial and the column perfectly straight before the application of the load, and these assumptions cannot be perfectly realized. It hence follows that factors of safety for compressive stress in columns should be lower than those in beams and lower than those for direct compression on short specimens.

Prob. 81*a*. A cylindrical wrought-iron column with fixed ends is 12 feet long, 6.36 inches in outside diameter, 6.02 inches in inside diameter, and carries a load of 49 000 pounds. Find its factor of safety.

Prob. 81*b*. A wooden stick, 3×4 inches and 12 feet long, is used as a column with fixed ends. Find its factor of safety under a load of 4 000 pounds. If the length of the stick is only one foot, what is the factor of safety?

ART. 82. SAFE LOADS FOR COLUMNS

To determine the safe axial load for a column of given length and cross-section, it is necessary to assume the allowable working unit-stress S . Then Rankine's formula gives,

$$P = aS / [1 + \phi(l/r)^2]$$

in which ϕ is to be taken from Art. 80, and the slenderness ratio l/r is to be computed from the given data.

For example, let it be required to determine the safe load for a fixed-ended timber column, 3×4 inches in size and 10 feet long, so that the greatest compressive unit-stress S may be 800 pounds per square inch. Hence $a = 12$ square inches, $l = 120$ inches, $r^2 = 4 \times 3^3 / 12 \times 12 = \frac{3}{4}$, and $l^2/r^2 = 19\ 200$; also $\phi = \frac{1}{3000}$. Then the formula gives $P = 1\ 300$ pounds for the safe load. A short column of this size should safely carry $P = 12 \times 800 = 9\ 600$ pounds, or seven times as much as one of 10 feet length.

As a second example let it be required to find the axial load for a fixed-ended steel column 23 feet 6 inches long so that S may be 12 000 pounds per square inch. Let the section be that in Fig. 76c, the plate being $\frac{3}{4} \times 16$ inches and each channel 12 inches deep and weighing $20\frac{1}{2}$ pounds per linear foot. From the principles of Arts. 42 and 43, with the help of Table 9, the least radius of gyration of the section is found to be $r = 4.56$ inches, so that the slenderness ratio is $l/r = 61.8$. Then Rankine's column formula gives

$$P = 24.06 \times 12\,000 \left/ \left(1 + \frac{61.8^2}{25\,000} \right) \right. = 250\,500 \text{ pounds}$$

which is the safe load for the given section. By using heavier channels of the same depth a much greater load may be carried without changing the outside dimensions of the section.

Prob. 82a. Find the safe steady load for a hollow cast-iron column with fixed ends, the length being 18 feet, outside dimensions 4×5 inches, inside dimensions 3×4 inches.

Prob. 82b. Find the safe load for the above steel column when the channels are 12 inches deep and weigh 40 pounds per linear foot, all other dimensions and requirements remaining the same.

ART. 83. DESIGN OF COLUMNS

When a column is to be selected or designed the axial load P will be given, as also its length and the condition of the ends. A proper allowable unit-stress S is assumed, suitable for the given material under the conditions in which it is used, or the value of S will be given in the specifications under which the design is to be made. Then from formula (1), the section area of a short column or prism is P/S , and it is certain that a greater section area will be needed for the column. Next, let a cross-section be assumed, bearing in mind that it will be more effective the further the material be removed from the axis (Art. 77). For this assumed cross-section a and r are to be determined, and then S is to be computed from the column formula. If this computed value agrees with the unit-stress assumed or specified, a section has been designed which satisfies the conditions; if

not, a new cross-section is to be assumed and S be again computed; this process is to be continued until a satisfactory agreement is secured.

For example, a hollow cast-iron rectangular column, with fixed ends and 18 feet in length, is to carry a load of 60 000 pounds and the allowable unit-stress S is to be 15 000 pounds per square inch. For a short length the area required would be four square inches; assume then that about 6 square inches will be needed. Let the section be square, the outside dimensions 6×6 inches, and the inside dimensions $5\frac{1}{2} \times 5\frac{1}{2}$ inches. Then $a = 5.75$ square inches, $l = 216$ inches, $r^2 = 5.52$ inches², $l/r = 92$, and $\phi = \frac{1}{80000}$. Substituting these in Rankine's formula, there is found for S about 30 000 pounds per square inch, which is double the specified value, and hence the assumed dimensions are much too small. Again, assume the outside dimensions as 6×6 inches and the inside dimensions as 5×5 inches. Then $a = 11$ square inches, $r^2 = 5.08$ inches², and $l/r = 96$. Substituting these in the formula, there is found for S about 15 700 pounds per square inch. Since this is very near the required working stress, it appears that these dimensions very nearly satisfy the imposed conditions. Many other sections can also be found which will satisfy the requirements, and the one to be finally selected will be that which is most convenient and economical.

In some instances it is possible to assume all the dimensions of the column except one, and then after expressing a and r in terms of this unknown quantity, to introduce them into (80) and solve the problem by finding the root of the equation thus formed. For example, let it be required to find the size of a square wooden column with fixed ends and 24 feet long to sustain a load of 100 000 pounds with a factor of safety of 10. Let x be the unknown side; then $a = x^2$ and $r^2 = \frac{1}{12}x^2$, and the column formula becomes,

$$800 = \frac{100\ 000}{x^2} \left(1 + \frac{24^2 \times 12^3}{3\ 000 \times x^2} \right)$$

By reduction this leads to the biquadratic equation,

$$8x^4 - 1\ 000x^2 = 331\ 776$$

and its solution gives 16.6 inches for the side of the column.

In designing columns and beams, considerations of economy are to be constantly kept in mind. For any given data, it is usually possible to arrange a large number of sections which will satisfy the requirements regarding strength, and the most advantageous one of these is that which can be built at the lowest possible cost. In architecture, considerations of beauty are also to be followed in order that the eye may be pleased with the view of the column. It is sometimes said that beautiful forms are those of greatest strength, and this now and then happens to be the case, but beauty and economy are usually contradictory elements.

Prob. 83. Compute the size of a square wooden column, 12 feet long and having fixed ends, to carry an axial load of 50 net tons with a factor of safety of 10. Compute also the size of the column for the case of round ends.

ART. 84. THE STRAIGHT-LINE FORMULA

The column formula (80) was derived by Rankine about 1860 from older forms deduced by Tredgold and by Gordon, in which the ratio l/d was used, d being the least thickness of a rectangular section or the diameter of a circular section; Rankine introduced the ratio l/r and thus produced a formula applicable to all kinds of cross-sections. This formula has been more widely used than any other notwithstanding its empirical nature. When it is compared, however, with the results of many experiments, it is seen that in many cases these results may be represented by a straight line, within the limits of the ratio l/r generally used, almost as well as by the curve of Rankine's formula. On this basis the straight-line formula for columns was first deduced in 1886 by T. H. Johnson.

On Fig. 84 are shown fifteen points which represent the average results of about sixty experiments made by Tetmajer on struts of medium steel of different lengths and sizes, the ordinate for each point giving the unit-load P/a which caused the failure of the struts having the slenderness ratio l/r corresponding to its abscissa. The broken curve is that of Euler's formula and

it is seen to fit the observations very well for values of l/r greater than 150. For lower values of l/r the full straight line seems to give a fair average representation of the observations, this being drawn tangent to Euler's curve. It is required to determine the equation of this straight line.

Let y be the ordinate P/a and x the abscissa l/r and S be the value of P/a when x is zero, or the distance from the origin to the point where the straight line cuts the axis of ordinates. Then the equations of Euler's curve and of the straight line are,

$$y = \mu E/x^2 \quad \text{and} \quad y = S - Cx$$

in which the parameter C is to be determined by making the straight line tangent to the curve. By equating the values of y in these two equations and also the values of the first derivatives $\delta y/\delta x$, the ordinate and abscissa of the point of tangency are found to be,

$$y_1 = \frac{1}{3}S \quad \text{and} \quad x_1 = (3\mu E/S)^{\frac{1}{2}}$$

Inserting these in the equation of the straight line, the value of C is found, and accordingly may be written,

$$C = \frac{2}{3}S \left(\frac{S}{3\mu E} \right)^{\frac{1}{2}} \quad \text{and} \quad \frac{P}{a} = S - C \frac{l}{r} \tag{84}$$

in which the number μ is π^2 for round ends, $2\frac{1}{2}\pi^2$ for one end round and the other fixed, and $4\pi^2$ for fixed ends (Art. 78).

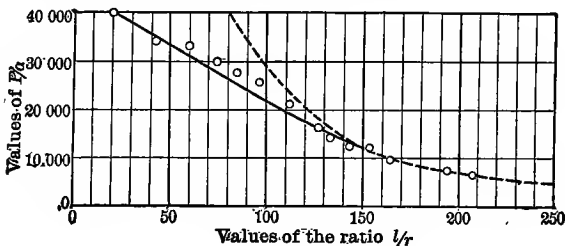

FIG. 84

The values of S to be used for cases of rupture are such as to make the straight line agree best with experimental results. The values derived by Johnson are given in the following table, together with his values of C and the limiting values of l/r corre-

sponding to the point of tangency. The above theoretic values of μ were not used in computing C , as his experiments indicated that the numbers π^2 , $1\frac{2}{3}\pi^2$, and $2\frac{1}{2}\pi^2$ for round, hinged, and flat ends respectively gave a closer agreement. It will be noticed

CONSTANTS FOR FORMULA (84)

Kind of Column	Pounds per Square Inch		Limit of l/r
	S	C	
Wrought iron			
Flat ends	42 000	128	218
Hinged ends	42 000	157	178
Round ends	42 000	203	138
Structural steel			
Flat ends	52 500	179	195
Hinged ends	52 500	220	159
Round ends	52 500	284	123
Cast iron			
Flat ends	80 000	438	122
Hinged ends	80 000	537	99
Round ends	80 000	693	77
Oak			
Flat ends	5 400	28	128

that the values of S in the table are less than the average ultimate compressive strengths given in Art. 5. For ductile materials like wrought iron and structural steel, this should be the case in columns, since when the elastic limit is passed a flow of metal begins which causes the lateral deflection to increase, and failure then rapidly follows.

The straight-line formula is not suitable for investigating a column, that is, for determining values of S due to given loads, because S enters the formula in such a manner as to lead to a cubic equation when it is the only unknown quantity. It may be used to find the safe load for a given column to withstand a given unit-stress S , or to design a column for a given load and unit-stress. When so used, it is customary to divide the values of S and C given in the table by an assumed factor of safety. For example, Cooper's specifications require that the section area a for a medium-steel post of a through railroad bridge shall

be found from $P/a = 17\,000 - 90(l/r)$ pounds per square inch, in which P is the direct dead-load compression on the post plus twice the direct live-load compression; the values of S and C here used are a little less than one-third of those given in the table for round ends.

While the straight-line formula is sometimes slightly more convenient than that of Rankine, it cannot be regarded either as having so high a degree of validity or as satisfying so well the results of experiments. It is hence advisable that the use of this formula should be limited to cases in which specifications require it to be employed, and for rough approximate computations.

Prob. 84. Solve Probs. 82*a* and 83 by the help of the straight-line formula, applying the factors of safety to the values of S and C given in the above table.

ART. 85. OTHER COLUMN FORMULAS

Many attempts have been made to establish a formula for columns which shall be theoretically correct, like the flexure formula (41) for beams, when the material is not stressed beyond the elastic limit. Although many column formulas have been proposed which have been claimed by their authors to have a rational basis, none of them has been so recognized by the engineering profession as more satisfactory than the formula of Rankine. For long columns all agree that Euler's formula is correct in giving the load which causes failure by lateral bending, but for the columns commonly used in practice, where the slenderness ratio l/r lies between 30 and 150, a fully satisfactory formula has not been established.

In 1873 Ritter proposed a formula to be used when the unit-stress S does not exceed the elastic limit S_e , namely,

$$\frac{P}{a} = \frac{S}{1 + (S_e/\mu E)(l/r)^2}$$

in which P/a is the axial unit-load, E the modulus of elasticity of the material, and the number μ is π^2 for round ends, $2\frac{1}{4}\pi^2$ for one end round and the other fixed, and $4\pi^2$ for both ends

fixed. This is seen to be the same in form as Rankine's formula, the constant ϕ having the value $S_c/\mu E$. Using the average values of S_c and E given in Arts. 2 and 9, the values of ϕ for columns of different materials are,

	Ends Fixed	Fixed and Round	Ends Round
for Timber	$\frac{1}{20\ 000}$	$\frac{1.78}{20\ 000}$	$\frac{4}{20\ 000}$
for Cast Iron	$\frac{1}{30\ 000}$	$\frac{1.78}{30\ 000}$	$\frac{4}{30\ 000}$
for Wrought Iron	$\frac{1}{40\ 000}$	$\frac{1.78}{40\ 000}$	$\frac{4}{40\ 000}$
for Structural Steel	$\frac{1}{34\ 000}$	$\frac{1.78}{34\ 000}$	$\frac{4}{34\ 000}$

These values of ϕ are smaller than the empirical ones in Art. 80, and hence the formula of Ritter gives larger values of P/a than the formula of Rankine. When l/r is 100, the values of P/a for fixed-ended columns found from Ritter's formula are 2 percent greater than those given by Rankine's formula for wrought iron, 8 percent greater for structural steel, 230 percent greater for cast iron, and 290 percent greater for timber. While the comparison is fairly satisfactory for wrought iron and medium steel, the disagreement in the results for cast iron and timber is so great that Ritter's formula cannot be regarded as satisfactory.

Another formula which has received extended discussion is that derived by Crehore in 1879 and also independently deduced by Reuleaux, Marburg, and others. This formula is identical with that of Ritter except that S_c is replaced by S ; designating P/a by B , it may be written,

$$B = \frac{S}{1 + (S/\mu E)(l/r)^2} \quad \text{or} \quad S = \frac{B}{1 - (B/\mu E)(l/r)^2}$$

from the first of which the unit-load may be computed for a given unit-stress, while the second gives the compressive unit-stress on the concave side of the column due to a given unit-load. Tables giving values of S for wrought iron and steel columns were published by Merriman in 1894, together with a deriva-

tion different from that of Crehore. These tables show that values of P/a computed for a given unit-stress S are greater than those found from Rankine's formula; for instance, when $l/r=100$ and $S=12\ 000$ pounds per square inch, it gives $P/a=11\ 000$ for steel columns with fixed ends, whereas Rankine's formula gives $P/a=8\ 500$ pounds per square inch. In general the formula gives working unit-loads which are from 20 to 30 percent greater than those allowable in good engineering practice and hence it cannot at present be regarded with favor. On the other hand when applied to cases of rupture, it usually gives values of P/a less than those shown from experiment and for this reason it is also unsatisfactory.

The discussions of this chapter show that the theory of columns stands upon a less rational basis than that of beams. The flexure formula $S \cdot I/c=M$ has a sound theoretical foundation and, for all cases where the elastic limit is not exceeded, it is found to agree with experiment. Euler's formula for long columns has a sound theoretical basis and it also agrees with experiment, but all other column formulas contain certain theoretic defects. A rational formula can often be safely applied to cases of rupture by using empirical constants, but it is rarely the case that an empirical formula containing constants deduced from experiments on rupture can be applied to cases in which the elastic limit is not exceeded, except by the use of arbitrary factors of safety. For this reason Rankine's formula is not a satisfactory one, and yet the long use of it by the engineering profession has built up a system of practice and precedent which must continue to be respected until the time arrives when a satisfactory theoretical formula shall be established. The present indications are that the errors of Rankine's formula, when used with the average empirical values of ϕ given in Art. 80, are on the side of safety.

Prob. 85a. Refer to Van Nostrand's Engineering Magazine for December, 1879, and ascertain the assumption used by Crehore in his derivation of the above column formula. Concerning the validity of this assumption, refer to the remarks in the last paragraph of Art. 88.

ART. 86. ECCENTRIC LOADS ON PRISMS

In all the preceding discussions, the load on the column has been regarded as axial, but cases are very common in engineering practice where the load P is applied at the distance p from the axis of the column; this lever arm p is called the "eccentricity" of the load. It is evident that the flexural stresses in the column will increase with p and that the total unit-stress S on the most compressed side of the column will be greater than for the case of an axial load.

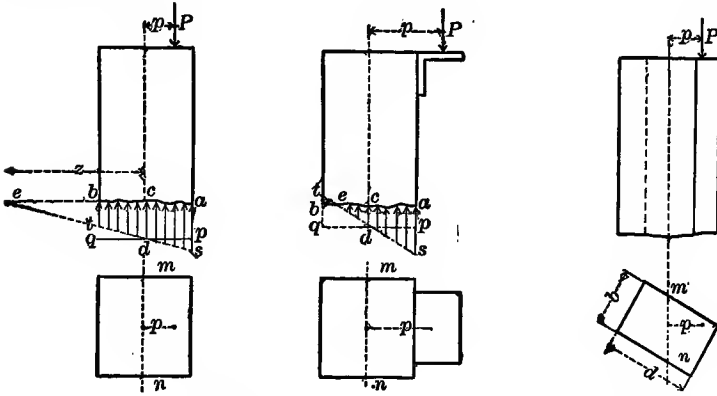

Fig. 86a

Fig. 86b

Fig. 86a shows two rectangular columns with eccentric loads. In the first diagram, the weight P on the top has a resultant shown by the arrow which falls within the cross-section; in the second, this resultant line falls without the cross-section. In these two diagrams, the point of application of P is on a median line of the cross-section, and this is the common case in practice, but Fig. 86b shows the unusual case where the point of application is not on a median line of the cross-section of the column. In all instances of eccentric loads, however, the tendency of the load is to cause rotation about an axis perpendicular to direction of the lever arm p . Thus, in each of the figures, let mn be drawn in the plane of the cross-section through the axis of the column and normal to p ; then the flexural stresses are to be referred to mn as a neutral axis, and the moment of inertia

of the cross-section with respect to this axis mn is to be determined by the methods of Art. 43. The shaded areas in Fig. 86*a* show the compressive unit-stresses due to the eccentric load when the elastic limit of the material is not exceeded, the variation occurring at a uniform rate.

It will now be shown that, whatever the shape of the section area a , the unit-stress along the axis of the column, due to the eccentric load P , is P/a . Let the total unit-stress as on the side of the column nearest the load be called S , and the unit-stress cd along the axis of the column be called B ; it is required to prove that $B=P/a$. For this purpose let pq be drawn parallel to ab , then ap is B and ps is $S-B$. Now from the flexure formula (41) there may be written $(S-B)/c=M/I$, where c is the distance ca in the figure and I is the moment of inertia of the section area with respect to the neutral axis mn . Now let ab and st be produced until they meet in e at the distance z from the axis of the column and let e be taken as an axis of moments; then the flexure formula is $S/(c+z)=M'/I'$, where M' is the moment of P and I' the moment of inertia of the section with respect to an axis through e parallel to mn . From similar triangles it is seen that $(S-B)/c$ equals B/z and also that $S/(c+z)$ equals B/z ; accordingly,

$$B/z=M/I \quad \text{and} \quad B/z=M'/I'$$

are two formulas for determining B and z . Since $M=Pp$ and $M'=P(p+z)$, while $I=ar^2$ and $I'=ar^2+az^2$, where r is the radius of gyration of the section with respect to the axis mn , the solution of the two equations gives the results,

$$B=P/a \quad \text{and} \quad z=r^2/p$$

Therefore, the unit-stress along the axis of the column equals the unit-load P/a , and the product of the lever arm p and the distance z equals the square of the radius of gyration of the section.

The total compressive unit-stress S now immediately results from the flexure formula $(S-B)/c=M/I$. Inserting in this the values of M and I , and that of B just found, it becomes,

$$S=\frac{P}{a}\left(1+\frac{cp}{r^2}\right) \quad \text{whence} \quad \frac{P}{a}=\frac{S}{1+cp/r^2} \quad (86)$$

from which S can be computed for a given P , and P/a be found for a given S . This formula is strictly applicable only to short prisms, since it takes no account of the lateral deflection of the column.

When the cross-section is a rectangle having the depth d in a plane passing through P and the axis, the value of r^2 is $\frac{1}{12}bd^3/bd = \frac{1}{12}d^2$, and since c is $\frac{1}{2}d$ for this case, the expression for S becomes $P/a[1+6(p/d)]$, which is the same result as found in Art. 29. When the cross-section is a circle of diameter d , the value of r^2 is $\frac{1}{16}d^2$ and that of c is $\frac{1}{2}d$; hence the expression for S reduces to $P/a[1+8(p/d)]$. The above formula, indeed, applies to all forms of cross-section, provided the unit-stress S does not exceed the elastic limit of the material.

Let c' be the distance from the axis of the column to the other side of the column where the unit-stress is S' ; then the value of S' is $(P/a)(1-c'p/r^2)$ and S' will be tensile when p is greater than r^2/c' ; this case is shown in the second diagram of Fig. 86a, where the point e is within the section.

For columns having ratios of slenderness between 30 and 100, a common method of taking into account the effect of an eccentric load is to add the flexural unit-stress above found to that given by Rankine's formula; thus results,

$$S = \frac{P}{a} \left(1 + \phi \left(\frac{l}{r} \right)^2 + \frac{cp}{r^2} \right) \quad (86)'$$

for the greatest compressive unit-stress on the concave side of the column. This formula may be used to investigate the strength of a column, to compute the safe load, or to design a column section by methods exactly like those explained in Arts. 81-83.

When several loads P_1, P_2 , etc., are on the column at the distances p_1, p_2 , etc., from the axis, their sum or resultant is P and its lever arm with respect to the axis is found from $p = (P_1p_1 + P_2p_2 + \text{etc.})/P$. In this manner all the acting loads are replaced by a single load P having the eccentricity p .

Prob. 86a. Using formula (86)' solve Prob. 82a, taking the eccentricity of the load as $1\frac{1}{4}$ inches.

Prob. 86*b*. Using formula (86)' solve Prob. 83, taking the eccentricity of the given load as $2\frac{1}{2}$ inches.

ART. 87. ECCENTRIC LOADS ON COLUMNS

The investigation of the last article gives results for S which are too small, especially for columns having a slenderness ratio greater than about 100, since the lateral deflection of the column due to the eccentric load will increase the eccentricity of the load for all sections except those at the ends. Thus, in the following figures, let p be the eccentricity of the load P , and f the maximum deflection of the axis of the column from its original straight position; then the lever arm or eccentricity of the load with respect to the neutral axis of the dangerous section is $p+f$, which may be called q , so that formula (86) becomes,

$$S = \frac{P}{a} \left(1 + \frac{cp}{r^2} + \frac{cf}{r^2} \right) = \frac{P}{a} \left(1 + \frac{cq}{r^2} \right) \quad (87)$$

and hence f or q must be determined in order to find S .

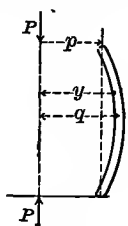
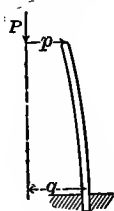
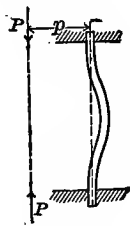
Fig. 87*a*Fig. 87*b*Fig. 87*c*

Let P_0 be the axial load given by Euler's formula for long columns, and suppose that this load is applied to the column when it has the deflection f , the eccentric load P being removed. Then this load P_0 will hold the long column in equilibrium and its moment with respect to the axis of the dangerous section is $P_0 f$, while the moment of the eccentric load with respect to the same section was $P(p+f)$. Equating these moments, it follows that,

$$f = Pp / (P_0 - P) \quad \text{and} \quad q = P_0 p / (P_0 - P)$$

which indicates that the deflection of a column under an eccentric load is determinate, although under an axial load it is indeter-

minate. Deflections computed from this formula are, however, too small, because it has been deduced by considering only the moment at the middle of the column, whereas all moments should be taken into account.

Let Fig. 87*b* represent a column of length l which is free at the upper end and vertically fixed at its lower end. Let the origin of coordinates be taken at the top under the load, values of x being measured downward and those of y horizontally. The bending moment for any point of the elastic curve is $-Py$, and hence $EI \cdot \delta^2 y / \delta x^2 = -Py$, in which I is moment of inertia of the cross-section and E is the modulus of elasticity of the material. Integrating this and determining the constant by the condition that the tangent $\delta y / \delta x = 0$ when $y = q$, there results $EI \cdot \delta y^2 / \delta x^2 = P(q^2 - y^2)$. Integrating again and ascertaining the constant by the condition that $y = p$ when $x = 0$, there is found,

$$\text{arc sin} \frac{y}{q} = (P/EI)^{\frac{1}{2}} x + \text{arc sin} \frac{p}{q}$$

for the equation of the elastic curve. From this equation the total eccentricity q is determined by making $x = l$ for $y = q$, and,

$$p = q \sin[\frac{1}{2}\pi - (P/EI)^{\frac{1}{2}} l] \quad \text{whence} \quad q = p \sec(P/EI)^{\frac{1}{2}} l$$

Now let θ represent the number $(P/EI)^{\frac{1}{2}} l$, this being an angle measured in radians. Then the value of q is given by,

$$q = p \sec \theta = p(1 + 0.5\theta^2 + 0.208\theta^4 + 0.0847\theta^6 + \dots) \quad (87)'$$

where the quantity in the parenthesis is obtained by expanding $\sec \theta$ into a series by Maclaurin's theorem.

By referring to Art. 78 it will be seen that the above value of q applies to a column with two round ends if l is replaced by $\frac{1}{2}l$, to a column with one end round and the other fixed if l is replaced by $\frac{1}{3}l$, and to a column with two fixed ends if l is replaced by $\frac{1}{4}l$. Accordingly in (87) let the unit-load P/a be represented by B ; also in the value of θ let I be replaced by ar^2 , where r is the least radius of gyration of the section. Then the formula,

$$S = B \left(1 + \frac{cP}{r^2} \sec \theta \right) = B + B \frac{cP}{r^2} (1 + 0.5\theta^2 + 0.208\theta^4 + \dots) \quad (87)''$$

applies to all columns, when θ^2 has the following values:

for one end free and the other fixed,	$\theta^2 = B/E \cdot (l/r)^2$
for both ends round,	$\theta^2 = \frac{1}{4}B/E \cdot (l/r)^2$
for one end round and the other fixed,	$\theta^2 = \frac{1}{2}B/E \cdot (l/r)^2$
for both ends fixed,	$\theta^2 = \frac{1}{16}B/E \cdot (l/r)^2$

In computing the unit-stress S , the second expression given is usually preferable, since the first one requires the use of a trigonometric table. When B approaches the unit-load given by Euler's formula, then θ^2 approaches the value $\frac{1}{4}\pi^2$, and for this value the series is not convergent. When θ is greater than unity, it will usually be necessary to find $\sec\theta$ with the help of a table.

For example, let the unit-load B be 10 000 pounds per square inch, applied at a distance of 1.01 inches from the axis of a steel column having round ends, the length of the column being 192 inches, the distance c being 4.45 inches, and the radius of gyration in the direction of the eccentricity being 3.00 inches. Hence $\theta^2 = \frac{1}{4}(B/E)(l/r)^2 = 0.3413$, and then the series in (87)'' gives $S = 16 900$ pounds per square inch, so that the eccentric load increases the mean unit-stress about 69 percent. Or, using the value of θ , formula (87)' gives $q = 0.197$ inches and then from (87) the unit-stress S is directly found.

To illustrate the computation of $\sec\theta$ and at the same time show the great influence of an increase in length of the column, take the same data as above except that the length is twice as great, or 384 inches. Then, $\theta^2 = 1.3653$ and $\theta = 1.168$ radians = $65^\circ 45'$, whence from a trigonometric table $\sec\theta = 1.934$. Accordingly the total eccentricity is $q = 1.934p = 1.934$ inches, and the unit-stress S is 29 300 pounds per square inch.

When a column is to be designed, its length and eccentric load are given, as also the allowable unit-stress S , and such values of a , c , and r are to be found as will satisfy (87)'' and at the same time give the greatest economy. This process is a tentative one, and several trials may be necessary in order to find a satisfactory section. Probably the best plan is to assume values of a , c , and r and then compute S , continuing the process until the computed allowable values fairly agree.

The above formula (87)'' is not convenient for the direct computation of the eccentric unit-load P/a for a given column under a given unit-stress S , and hence a problem of this kind is also to be solved by successive trials, values of P/a or B being inserted in the formula until one is found which makes S the same as the given value. This process, as also that of designing a column section, will be often facilitated by assuming $\sec\theta$ for the first trial, taking it as unity if the column is short, or about $1\frac{1}{2}$ or 2 for a long column.

Prob. 87a. Show that $(p+f)c$ equals r^2 for a column so deflected that there is no stress on the convex side.

Prob. 87b. A wooden strut with fixed ends is 18 feet long, 4 inches square, and the compression of 5 000 pounds is applied half-way between the center and corner of the end sections. Compute the deflection at the middle of the column, and the maximum unit-stress S .

Prob. 87c. Prove that the eccentric load P which holds a round-ended column in equilibrium with the deflection $q-p$, is given by the formula $P/a = 4E(r/l)^2(\text{arc } \cos p/q)^2$.

ART. 88. ON THE THEORY OF COLUMNS

An ideal column is one which is perfectly straight in its original unstressed condition and which remains perfectly straight after the application of an axial load P . The unit-stress is then uniform in every cross-section and equal to P/a . When P/a is as large as the value given by Euler's formula and at the same time less than the elastic limit of the material, the column, if deflected laterally by a slight force, will remain bent in indifferent equilibrium when that force is removed. Under ideal conditions, however, no lateral deflection can occur and the column remains perfectly straight under the axial load.

The length of the ideal column being originally l , its shortening under the axial load is $e = Pl/aE$ (Art. 9), from which $P/a = Ee/l$. Now Euler's formula gives $P/a = \mu E(r/l)^2$, and equating the two values of P/a , there is found $e = \mu r^2/l$. The shortening of the column, when the load reaches the value given by Euler's

formula, hence depends only upon its length, the radius of gyration of the cross-section, and the condition of the ends. Accordingly, columns of different materials have the same change in length when they are loaded up to the value given by Euler's formula, the unit-shortening being $e/l = \mu(r/l)^2$, in which the values of μ are those given in Art. 78. This conclusion is an interesting one, and it may perhaps prove valuable in future discussions.

The ideal column under the axial load P has the uniform unit-stress P/a in every cross-section, and the greatest value of this must be less than the elastic limit of the material, since Euler's formula involves this condition. Now if P/a in Euler's formula be replaced by S_e it becomes,

$$S_e = \mu E (r/l)^2 \quad \text{or} \quad l/r = (\mu E / S_e)^{\frac{1}{2}}$$

from which values of the slenderness ratio l/r can be computed for different cases. These critical values are the least ones to which Euler's formula can apply. For instance, columns of structural steel with round ends, for which $\mu = \pi^2$, give $l/r = 92$, while columns of structural steel with fixed ends, for which $\mu = 2\pi^2$, give $l/r = 184$; the values of E and S_e being 30 000 000 and 35 000 pounds per square inch respectively. These critical values are shown in Fig. 88 by the broken-line ordinates. For all values of l/r greater than these critical values, Euler's formula applies to the ideal column; for smaller values, the greatest allowable uniform unit-stress P/a is S_e . The curves drawn with broken lines show the ultimate unit-loads as given by Rankine's formula.

One of the methods of deriving Ritter's formula (Art. 85) is to obtain the equation of a curve which shall be tangent to Euler's curve and also to the horizontal straight line which gives the value of P/a for values of l/r less than the critical values. Such a curve is shown in the figure for the case of round-ended columns, and its equation can be deduced by a method similar to that given in Art. 84. Let x be the abscissa l/r , and y the ordinate P/a , referred to the rectangular axes. Let it be assumed that the equation of the curve is similar in form to that of Rankine's formula (Art. 80). Then the equations of the curves

corresponding to the formulas of Rankine and Euler are,

$$y = \frac{S_e}{1 + \phi x^2} \quad \text{and} \quad y = \frac{\mu E}{x^2}$$

Now let these curves be tangent to each other; for the point of tangency the two ordinates are equal, as also the two derivatives $\delta y / \delta x$. Obtaining and solving these equations, there results $x_1 = \infty$ for the point of tangency, and $\phi = S_e / \mu E$ for the value of the constant ϕ . Accordingly,

$$y = \frac{S_e}{1 + (S_e / \mu E)x^2} \quad \text{or} \quad \frac{P}{a} = \frac{S_e}{1 + (S_e / \mu E)(l/r)^2}$$

is a column formula which satisfies the limiting conditions of the ideal column, but which, as noted in Art. 85, cannot be regarded as entirely satisfactory for actual columns.

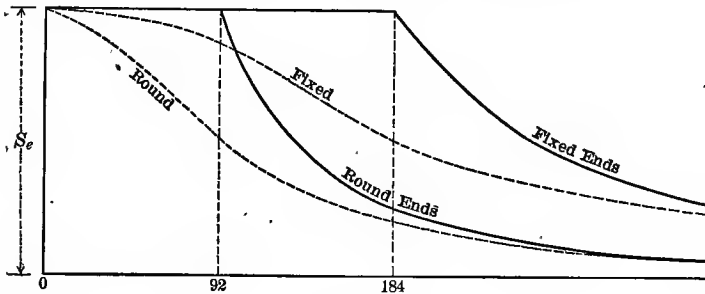

Fig. 88

When a steadily increasing axial load P is applied to an actual column, it may, on account of being non-homogeneous or not perfectly straight, begin to bend without the application of any lateral force long before P reaches the value given by Euler's formula. Suppose, for instance, that the column is slightly crooked so that it has an initial deflection p at a section near the middle. The actual deflection f will now be measured, not from the straight line joining the end sections, but from the axis passing through the section which has the initial deflection. Here there is no indeterminateness, for the case is exactly similar to that discussed in the last article. Since an actual column is never perfectly straight, and since the influence of a slight eccentricity at any section may be great, it is apparent that formulas

deduced from ideal conditions alone should be used with caution unless it is found that they are in satisfactory accord with experimental results. A formula which applies when the elastic limit of the material is not exceeded cannot, however, be verified by experiments on rupture.

The influence of the weight of the column itself has not been considered in the foregoing pages. When the column is in a vertical position, as is the case in buildings, it might appear, in accordance with Art. 28, that the section of the column should continually increase toward the base in order to give a form of uniform strength. For a long column, however, the form of uniform strength must be such that the greatest section comes at the place where the unit-stress S is the greatest, and this will be where the lateral deflection would be a maximum in case bending should occur. Disregarding the weight of the column itself, the greatest section should be at the middle; taking it into account, the greatest section should be below the middle. The Doric column of Greek architecture had its greatest diameter at the base, while the Ionic column was usually of constant diameter from the base up to about one-third of the height; sometimes, however, Ionic columns have a diameter at the base slightly less than that at one-third of the height. Since the length of these columns is usually less than ten diameters, it must be concluded that considerations of beauty rather than strength governed the evolution of these ancient forms.

When a column is placed in a horizontal position, its weight causes flexure which increases the deflection and stress due to the direct compression. This case will be discussed in Art. 104, and it will there be seen that the direct compression is sometimes applied eccentrically in order to counteract the flexure due to the weight of the column.

In conclusion, referring to Euler's formulas in Art. 78, it may be noted that the general formula of the elastic curve $EI\delta^2y/\delta x^2 = M$ should be slightly modified for a column under compression. Considering the demonstration in Art. 45, where δl is a short unstressed length, it is seen from Fig. 80a that this

length is decreased by the axial compression before the flexure takes effect. Introducing this idea in deriving the relations from the similar triangles, it is found that for the column the correct equation of the elastic curve is $(E - P/a)\delta^2 y / \delta x^2 = M$. This modifies Euler's formulas only very slightly, since P/a is small compared with E , and indeed a more marked modification results from the change in length due to the bending, as will be seen from the discussion in Art. 167.

Prob. 88a. Consult Tetmajer's *Gesetze der Knickungs- und der zusammengesetzten Druckfestigkeit* (Leipzig, 1903), and compare his formula for q with (87)'.

Prob. 88b. For a round-ended column under a load P having the eccentricity p , it may be shown, as was done by Moncrieff in *Transactions of American Society of Civil Engineers* for 1900, that

$$S = \frac{P}{a} \left(1 + \frac{cp}{r^2} \cdot \frac{1 + \beta}{1 - 5\beta} \right)$$

in which β represents the quantity $P^2/48Ear^2$. Compare this formula with (87)'' for one or more numerical cases.

CHAPTER X

TORSION OF SHAFTS

ART. 89. PHENOMENA OF TORSION

When applied forces cause a bar to twist around its axis, 'torsional stresses' arise. If a rectangular bar has one end fixed and forces are applied to the other end which cause twisting around its axis, the corners of the bar are seen to assume a spiral form similar to the threads of a screw. By experiments like those illustrated in Fig. 169c it has been proved that the phenomena of torsion are analogous to those of tension. Under small twisting forces the deformation, or angle of twist, is proportional to the force, so that the bar returns to its original form on the removal of that force. This law holds until an elastic limit is reached; beyond this limit the angle of twist increases more rapidly than the force, and a permanent set remains when the force is removed. Under further increase of the twisting force, the deformation rapidly increases and rupture finally occurs. In Fig. 169c are seen a square bar and a round bar which have been ruptured by torsion.

The force P which causes the twist acts in a direction normal to the axis of the bar or shaft with a certain lever arm p . Fig. 89 shows a horizontal shaft rigidly fixed at one end, while a weight P is hung on a lever at right angles to the axis of the shaft. Under the twisting moment Pp the shaft is deformed, so that an originally straight line ab becomes the helix ad , while the radial line cb has moved through the angle bcd . The angle bcd is evidently proportional to the length of the shaft, while the angle bad is independent of that length.

The product Pp is the moment of the force P with respect to the axis of the shaft, p being the perpendicular distance from that axis to the line of direction of P , and is called the 'twisting moment'. Whatever be the number of forces acting upon the

shaft, their resulting twisting moment may always be represented by a single product Pp . Thus, if the forces P_1 and P_2 act with lever arms p_1 and p_2 , the twisting moment $P_1p_1 + P_2p_2$ may be caused by a single force P with the lever arm p .

A graphical representation of the phenomena of torsion may be made in the same manner as the tension diagram of Fig. 4, the angles of torsion being taken as abscissas and the twisting moments as ordinates. The curve is then a straight line from the origin until the elastic limit of the material is reached, when a rapid change occurs and it soon becomes nearly parallel to the axis of abscissas. The total angle of torsion, like the total ultimate elongation, serves to compare the ductility of materials.

The principal stress which occurs in torsion is that of shearing, each section of the bar tending to shear off from the one adjacent

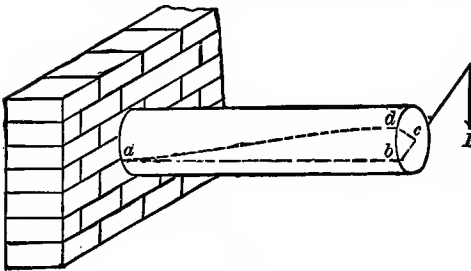

Fig. 89

to it. The direction of the shearing stress at any point in the section of a round shaft is normal to a radius drawn from the axis to that point, and the sum of the moments of all the stresses in any section is equal to the twisting moment Pp . For a round bar, like that of Fig. 89, a radial straight line cb is found to remain straight when displaced to the position cd , provided the shearing elastic limit of the material is not exceeded. For a square or rectangular bar, this is not the case when the radial line is drawn to a corner.

Prob. 89a. If a force of 80 pounds acting at 18 inches from the axis twists a shaft 15 degrees, what force will produce the same result when acting at 4 feet from the axis?

Prob. 89b. A shaft 2 feet long is twisted through an angle of 7 degrees by a force of 200 pounds acting at a distance of 6 inches from the axis. Through what angle will a shaft of the same size and material and 4 feet long be twisted by a force of 500 pounds acting at a distance of 18 inches from the axis?

ART. 90. THE TORSION FORMULA

It has been found by experiment that the laws governing the stresses in a section of a round bar under torsion are similar to those stated for beams in Art. 40, provided the elastic limit is not exceeded. The shearing unit-stresses are proportional to their distances from the axis, because it is observed that any radius, such as cb in Fig. 89, remains a straight line when it is displaced by the twisting into the position cd . The law of static equilibrium requires that the sum of the moments of these shearing stresses shall be equal to the twisting moment, or,

$$\text{Resisting Moment} = \text{Twisting Moment}$$

and this condition will now be expressed in algebraic language.

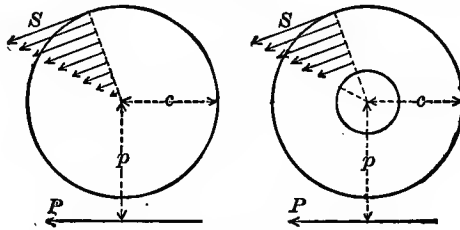

Fig. 90a

Let P be the force acting at a distance p from the axis about which the twisting takes place, then the value of the twisting moment is Pp . To find the resisting moment, let c be the distance from the axis to the outside of the circular cross-section where the shearing unit-stress is S . Then, since the shearing unit-stresses vary as their distances from the axis of the shaft,

$$S/c = \text{unit-stress at a unit's distance from axis}$$

$$S \cdot z/c = \text{unit-stress at a distance } z \text{ from axis}$$

$$\delta a \cdot Sz/c = \text{total stress on an elementary area } \delta a$$

$$\delta a \cdot Sz^2/c = \text{moment of this stress with respect to axis}$$

$$\Sigma \delta a \cdot Sz^2/c = \text{internal resisting moment}$$

Since S and c are constants, this resisting moment may be written $(S/c) \Sigma \delta a \cdot z^2$. But the quantity $\Sigma \delta a \cdot z^2$, being the sum of the products obtained by multiplying each element of area by the square of its distance from the axis, is the polar moment of

inertia of the cross-section and may be denoted by J . The resisting moment of the internal stresses hence is $S \cdot J/c$, and equating this to the twisting moment, there results,

$$S \cdot J/c = P\phi \quad \text{or} \quad S = P\phi \cdot c/J \quad (90)$$

which is the fundamental formula for investigating round bars and shafts that are subject to torsion. It will be called the torsion formula, but it must be borne in mind that it does not apply to square or rectangular sections; these will be discussed in Art. 99.

The flexure formula $S \cdot I/c = M$ for beams has a close analogy with the torsion formula. In the flexure formula, c is the distance from the neutral axis to the remotest fiber and that axis lies in the plane of the cross-section; in the torsion formula, c is the radius of the outside circumference of the round bar. In the flexure formula, S is a tensile or compressive unit-stress which is normal to the section area; in the torsion formula, S is a shearing unit-stress which acts along the section and normal to the radius. In the flexure formula, M is the bending moment of the external forces; in the torsion formula, $P\phi$ the twisting moment of the external forces.

By the help of the torsion formula, three problems like those of Arts. 48, 49, 50, may be discussed for round bars or shafts. When the dimensions and the allowable unit-stress are given, it may be used to compute the safe twisting moment $P\phi$. When the unit-stress S_s and the moment $P\phi$ are given, it may be used to design a shaft or bar, by determining dimensions which will give a value for J/c equal to $P\phi/S$. The results obtained in this discussion are only valid when the shearing unit-stress S does not exceed the elastic limit of the material, but it is shown in Art. 94 how the formula may be used for cases of rupture.

In the discussion of shafts, the moments of inertia of cross-sections are required with respect to a point at the center of the shaft and not with respect to an axis in the same plane, as in beams and columns. The 'polar moment of inertia' of a surface is defined as the sum of the products obtained by multiplying each elementary area by the square of its distance from the center of

gravity of the surface. Thus if δa is any elementary area and z its distance from the center, the quantity $\Sigma \delta a \cdot z^2$ is the polar moment of inertia of the surface.

In the figure let δa be any elementary area and y its distance from an axis AB passing through the center of gravity of the section; then $\Sigma \delta a \cdot y^2$ is the moment of inertia with respect to this axis AB (Art. 43). Also, if x is the distance from δa to an axis CD which is normal to AB , then $\Sigma \delta a \cdot x^2$ is the moment of inertia with respect to CD . But, since $z^2 = x^2 + y^2$, the product $\Sigma \delta a \cdot z^2$ is equal to $\Sigma \delta a \cdot x^2 + \Sigma \delta a \cdot y^2$; that is, the polar moments of inertia is equal to the sum of the moments of inertia taken with respect to any two rectangular axes.

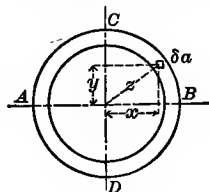

Fig. 90b

By the aid of the above principle, the polar moment of inertia J is readily found for a solid or hollow circular section from the values of I given in Art. 43. Let d be the diameter of a solid section or the outside diameter of a hollow one, and let d_1 be the inside diameter of a hollow one; then,

$$\begin{aligned} \text{for a solid shaft,} \quad c &= \frac{1}{2}d, & J &= \frac{1}{32}\pi d^4 \\ \text{for a hollow shaft,} \quad c &= \frac{1}{2}d, & J &= \frac{1}{32}\pi(d^4 - d_1^4) \end{aligned}$$

The polar radius of gyration r , defined by the equation $J = ar^2$, where a is the section area, is also sometimes used in formulas; it is the radius of a circumference along which the entire area might be concentrated and have the same polar moment of inertia as the actual distributed area. The value of r is always less than $\frac{1}{2}d$; for a solid circular section, $r^2 = \frac{1}{8}d^2$; for a hollow circular section, $r^2 = \frac{1}{8}(d^2 + d_1^2)$.

Prob. 90a. Three forces of 70, 90, and 120 pounds act at distances of 8, 11, and 6 inches respectively from the axis, and at different distances from the end of a shaft, the direction of rotation of the second force being opposite to that of the others. Find the three values of the twisting moment $P\phi$.

Prob. 90b. A circular shaft is subjected to a maximum shearing unit-stress of 2 000 pounds when twisted by a force of 90 pounds at a distance of 27 inches from the axis. Compute the unit-stress produced by a force of 40 pounds at 21 inches from the axis.

ART. 91. TRANSMITTING POWER BY SHAFTS

Power from a motor is often transmitted to a shaft through a belt, and then the shaft transmits the power to the places where the work is to be performed. The shaft of a turbine wheel transmits the power generated by water in passing through the wheel directly to dynamos or other machinery. The shaft of an ocean steamer transmits the power of the engines directly to the screw propellers. In all these cases the shaft is subject to a twisting moment Pp which produces in it shearing stresses and causes it to have a certain angle of twist.

The twisting moment Pp due to the transmission of H horse-powers through a shaft may be found as follows: Suppose P to be the tangential force brought by a belt on the circumference of a pulley of radius p_1 and let n be the number of revolutions made by the shaft and pulley in one minute. In one revolution the force P overcomes resistance through the distance $2\pi p$ and the work $P \times 2\pi p$ or $2\pi Pp$ is transmitted through the shaft; in n revolutions the work $2\pi n Pp$ is transmitted. Now let N be the number of units of work per minute which constitute one horse-power; then $2\pi n Pp = NH$, or $Pp = NH/2\pi n$. In the English system of measures, P is in pounds, p in inches, and N is 396 000 pound-inches per minute. In the metric system of measures, P is in kilograms, p in centimeters, and N is 450 000 kilogram-centimeters per minute. Accordingly,

$$Pp = 63\ 030H/n \quad \text{or} \quad Pp = 71\ 620H/n \quad (91)$$

the first being for the English and the second for the metric system of measures, while $Pp = (N/2\pi)H/n$ applies to all systems.

The above formula shows that the twisting moment Pp varies directly as the transmitted horse-power and inversely as the speed of revolution. Therefore, when the speed is low, as it is in starting, the full power should not be applied to a shaft, for it might render the twisting moment so great as to injure the material or to cause rupture.

Metallic shafts are usually round and the word 'shaft', when

used without qualification, means a solid round cylinder, properly supported in bearings. Square shafts are rarely used except for wooden water wheels, and the torsion formula (90) does not apply to these unless modified in the manner indicated in Art. 99. Hollow sections have been much used since 1900 for the large shafts of ocean steamers. These are advantageous in being of lighter weight than solid shafts of the same strength and capacity, as the investigation in Art. 95 will show; these shafts are forged upon a mandrel and the inside surface is hence subject to the same treatment as the outside surface.

In designing a shaft to resist a given twisting moment $P\phi$ the factors of safety may be based upon the average shearing strengths of materials which are given in Art. 6. The rule that an allowable unit-stress S should not exceed the shearing elastic limit of the material should also be observed, although there is considerable uncertainty as to the average values of this limit. Probably the elastic limits for shearing are about three-fourths of those for tension.

Prob. 91a. Show that the metric horse-power is 1.4 percent less than the English horse-power; also that one kilogram-meter is equivalent to 7.233 foot-pounds.

Prob. 91b. Find the horse-power that can be transmitted by a cast-iron shaft 3 inches in diameter when making 10 revolutions per minute, the value of S not to exceed 1200 pounds per square inch.

ART. 92. SOLID AND HOLLOW SHAFTS

For solid round shafts of diameter d , the values of J and c are $\frac{1}{32}\pi d^4$ and $\frac{1}{2}d$, and the torsion formula (90) reduces to

$$P\phi = \frac{1}{16}\pi d^3 S \quad \text{or} \quad S = 16P\phi/\pi d^3$$

which may be used for the discussion of shafts when the twisting moment $P\phi$ is required or given. The usual case, however, is that of the transmission of power, where the value of $P\phi$ for the English system of measures is $63030H/n$, as shown in Art. 91; inserting this in the last formula, it reduces to the forms,

$$S = 321000H/nd^3 \quad \text{or} \quad d = 68.5(H/nS)^{\frac{1}{3}} \quad (92)$$

The first of these may be used for investigating the strength of a given shaft when transmitting H horse-powers and making n revolutions per minute. The second may be used to determine the diameter of a shaft to transmit H horse-powers with n revolutions per minute, the allowable unit-stress for the circumference of the shaft being S . In both equations d must be taken in inches and S in pounds per square inch.

These equations show that the shearing unit-stress S at the circumference of a solid shaft varies directly as the transmitted power, inversely as the speed of the shaft, and inversely as the cube of its diameter. Hence for a given S and n , the diameter d changes slowly with H ; if H is doubled, d is increased only 26 percent, and the section area is increased 59 percent.

For example, let it be required to design a solid wrought-iron shaft to transmit 90 horse-power when making 250 revolutions per minute. Here the factor of safety may be about 6, or S may be about 7 000 pounds per square inch. Then from the above formula the diameter d is found to be $2\frac{5}{8}$ inches.

Hollow forged steel shafts are much used for ocean steamers, since their strength is greater than solid shafts of the same section area. Let d_1 be the outside and d_2 the inside diameter; then the value of J is $\frac{1}{32}\pi(d_1^4 - d_2^4)$ and that of c is $\frac{1}{2}d_1$. Inserting these in the torsion formula and also the value of $P\rho$ from (91), it becomes, for English measures,

$$S(d_1^4 - d_2^4)/d_1 = 321\,000H/n$$

which is the equation for use in investigation and design.

For example, a nickel-steel shaft of 17 inches outside diameter is to transmit 16 000 horse-powers at 50 revolutions per minute; let it be required to find the inside diameter so that the unit-stress S may be 25 000 pounds per square inch. Here everything is given except d_2 , and from the equation its value is found to be 11 inches nearly. The area of the cross-section of this shaft will be about 132 square inches, and its weight per linear foot about 449 pounds. A solid shaft having the same strength will require a diameter of 16 inches, its cross-section will be 201 square inches, and its weight per linear foot about 683 pounds.

The reason why economy is promoted by the use of a hollow shaft is the same as that given in Art. 51 for a hollow beam; namely, that material is removed from the axis where it is but little stressed and placed farther away where it is efficient in resisting the twisting moment. By comparing the above formulas for solid and hollow shafts, it is seen that they become the same when d^3 equals $(d_1^4 - d_2^4)/d_1$. When the section areas of the solid and hollow shafts are equal, d^2 must equal $d_1^2 - d_2^2$. From these two equations, it follows that the ratio of the strength of a hollow shaft to that of a solid one of the same section area is $(2d_1^2 - d^2)/dd_1$. For example, let $d = 12$ inches and $d_1 = 20$ inches; then d_2 is 16 inches from the condition of equal section areas, and the ratio of strengths is 2.73, that is, the strength of the hollow shaft is 173 percent greater than the solid one.

Prob. 92a. Find the factor of safety for a wrought-iron shaft $2\frac{1}{2}$ inches in diameter when transmitting 25 horse-power while making 100 revolutions per minute.

Prob. 92b. If a hollow shaft has the same section area as a solid one, the inside diameter being one-half the outside diameter, find the ratio of the strength of the hollow shaft to that of the solid one.

ART. 93. TWIST OF SHAFTS

The angle of twist through which a radius on one end of a round shaft moves under an applied twisting moment can be determined, when the unit-stress S does not exceed the elastic limit, from the definitions in Art. 15 with the help of the torsion formula (90). Let the section be of any shape, J its polar moment of inertia with respect to the axis about which rotation occurs, c the distance from that axis to the remotest part of the section where the shearing unit-stress is S , and F the shearing modulus of elasticity of the material. The modulus F is defined by S/ϵ , where ϵ is the deformation per unit of length. Let l be the length of the shaft, and ϕ the angle expressed in radians through which one end is twisted with respect to the other, that is the angle dcb in Fig. 89a. In this figure the arc bd is the deformation in the length l ; this deformation is $c\phi$ and hence the unit-deforma-

tion is $c\phi/l$. Accordingly $F = Sl/c\phi$, and replacing S by its value $Pp \cdot c/J$ there is obtained,

$$F = Pp \cdot l/J\phi \quad \text{or} \quad \phi = Pp \cdot l/FJ \quad (93)$$

The first of these equations may be used to compute values of the shearing modulus F from observed values of ϕ , while the second is for the determination of ϕ when F is given.

In order to compute the shearing modulus of elasticity from an observed value of the angle of twist the arc ϕ should be replaced by $\pi\phi_0/180$, where ϕ_0 is the angle in degrees; then,

$$\phi_0 = 57.3 Pp l / FJ \quad \text{or} \quad F = 57.3 Pp l / J\phi_0$$

By taking several corresponding values of Pp and ϕ_0 within the elastic limit, a good determination of F can be made. For example, the cast-iron specimen shown in Fig. 169c was 10 inches long and 0.83 inches in diameter, and it twisted through an angle of 1.3 degrees under a twisting moment of 600 inch-pounds; here $J = 0.0466$ inches⁴, and the formula gives $F = 5\,670\,000$ pounds per square inch. In this manner the average values of F have been found to be about 6 000 000 pounds per square inch for cast iron and about 12 000 000 pounds per square inch for steel.

The angle of twist which occurs when a shaft is under stress in the transmission of power may be determined in a similar manner. Let H horse-power be transmitted when the shaft makes n revolutions per minute; then $Pp = 63\,030H/n$ in English measures (Art. 91). Let ϕ_0 be angle of twist in degrees; then ϕ is to be replaced by $\pi\phi_0/180$. The formula now becomes,

$$\phi_0 = 3\,610\,000 H l / n F J \quad (93)'$$

in which l must be taken in inches, J in inches⁴, and F in pounds per square inch. For example, let a steel shaft 125 feet long, 17 inches outside diameter, and 11 inches inside diameter transmit 16 000 horse-powers at 50 revolutions per minute. Here $H = 16\,000$ horse-powers, $l = 1\,500$ inches, $n = 50$, $F = 12\,000\,000$ pounds per square inch, $J = 6\,765$ inches⁴. Then from the formula (93)' there is found $\phi_0 = 21.4$ degrees, which is the angle through which a point on one end is twisted relative to the corre-

sponding point on the other end. The angle through which a straight line on the outside of the shaft is twisted, that is, the angle bad in Fig. 89, is $c\phi_0/l = 8.5 \times 21.4/1500 = 0.12$ degrees.

The above formulas show that the angle of twist is proportional to the length of the shaft, and this is found to be also the case after the elastic limit of the material is exceeded, but the angle is then very much greater than that given by the formulas. In the case of the round cast-iron bar shown in Fig. 169c, the angle of twist at rupture was .12.3 degrees; this bar had a length of 10 inches and a diameter of 0.83 inches, and it broke under a twisting moment of 3910 pound-inches. For the square steel bar in Fig. 169c, which was 12 inches long, the angle of twist at rupture was about 900 degrees; further facts regarding this square bar are given in Art. 99.

Prob. 93a. A solid steel shaft 125 feet long and 16 inches in diameter transmits 8000 horse-powers at a speed of 25 revolutions per minute. Compute the angle of twist.

Prob. 93b. A wrought-iron shaft 5 feet long and 2 inches in diameter is twisted through an angle of 7 degrees by a force of 5000 pounds acting at 6 inches from its axis, and on the removal of the force it springs back to its original position. Compute the shearing modulus of elasticity.

ART. 94. RUPTURE BY TORSION

When a round bar or shaft is twisted to the point of rupture, failure occurs first at the outside circumference, and this is rapidly propagated inwards until complete shearing is effected. The torsion formula $S \cdot J/c = Pp$, does not, however, hold for cases for rupture, so that a value of S computed from it for the data of failure does not closely agree with the ultimate shearing strength of the material.

A value of the unit-stress S computed by the torsion formula from a twisting moment Pp which causes rupture, may be called the 'computed twisting strength' of the material, in analogy with the computed flexural strength obtained for the rupture of a beam by the use of the flexure formula (Art. 52). The following

are approximate average values of the computed ultimate twisting strength of different materials:

Timber	$S_u = 2\,000$ pounds per square inch
Cast Iron	$S_u = 30\,000$ pounds per square inch
Wrought Iron	$S_u = 55\,000$ pounds per square inch
Structural Steel	$S_u = 65\,000$ pounds per square inch
Strong Steel	$S_u = 90\,000$ pounds per square inch

By the use of these average values, computations may be made on the rupture of round shafts, that is, the probable twisting moment which will cause a given shaft to rupture, or the probable size of a shaft which will fail under a given twisting moment, may be roughly ascertained.

By comparing the above values with the ultimate shearing strengths given in Art. 6, it will be seen that they are all larger with the exception of timber. The statement is sometimes made that it might be anticipated that the two sets of values should be the same, but this rests on no reasonable basis. The ultimate shearing strength of a material is a physical constant, but the values of S_u have no physical meaning, for they have been computed from a formula which does not correctly represent the distribution of the internal stresses for cases of rupture. The quantity S_u is usually called the 'modulus of rupture for torsion', but it seems wise to abandon this term and to use one which gives no erroneous impression.

When that twisting moment $P\phi$ is reached in a test where the angles of twist ϕ no longer increase uniformly, the shearing elastic limit of the material is reached, and the elastic limit for shearing may be correctly computed from the torsion formula $S = P\phi \cdot c/J$. The shearing elastic limit of metals is always less than those for compression, and in general may be taken at about one-third of the computed twisting strength S_u . Experiments on timber, brick, and stone have been so few in number, that it is difficult to state average values of their shearing elastic limits.

In Fig. 169c is shown a cast-iron bar, 0.83 inches in diameter which broke by torsion under a twisting moment of 3 910 inch-

pounds. The computed ultimate twisting strength for this case is $S = 34\,800$ pounds per square inch, which is higher than the average for cast iron. The square bar of medium steel shown in Fig. 169c, which was 0.75 inches square, broke under a twisting moment of 5 800 inch-pounds; the torsion formula (90) cannot be applied to this case, as the discussion in Art. 99 will show.

Prob. 94. Compute the probable diameter of a wrought-iron shaft which will rupture by torsion when twisted by a force of 47 pounds acting at a distance of 47 inches from the axis.

ART. 95. STRENGTH AND STIFFNESS

The strength of a shaft or of a bar under torsion is measured by the twisting moment that it can carry. Hence the strengths of different shafts vary as their values of $S \cdot J/c$; or for the same material, the strengths vary as the values of J/c . For example, let there be two solid shafts of the same material, the diameter of the first being d and that of the second $2d$; since the section factor J/c is eight times as large for the second as for the first, it follows that their strengths are in the same ratio. Thus the strengths of solid shafts of the same material vary as the cubes of their diameters.

A general comparison of the strength of a round hollow shaft with that of a solid one having the same section area a will now be made. Let d be the diameter of the solid shaft, d_1 the outside and d_2 the inside diameter of the hollow shaft; then $d^2 = d_1^2 - d_2^2$ is the condition that the section areas shall be equal. Now, for the hollow shaft,

$$J/c = \pi(d_1^4 - d_2^4) / 16d_1 = \frac{1}{2}a(d_1^2 + d_2^2) / d_1$$

and in the same manner for the solid shaft,

$$J/c = \pi d^4 / 16d = \frac{1}{2}ad = \frac{1}{2}a(d_1^2 - d_2^2)^{\frac{1}{2}}$$

Therefore, dividing the first by the second, and letting α denote the ratio d_1/d_2 , there is found

$$\text{hollow/solid} = (\alpha^2 + 1) / \alpha(\alpha^2 - 1)^{\frac{1}{2}}$$

which is the ratio of the strength of a hollow shaft to that of a solid one of the same section area. When d_1 is double d_2 , the

value of α is 2, and the hollow shaft is about 44 percent stronger than the solid one.

The stiffness of a shaft under torsion is measured by the twisting moment it can carry with a given angle of twist. By Art. 93 it is seen that $P\phi$ varies directly with J , and hence the stiffness of a shaft varies directly as its polar moment of inertia. For the hollow shaft,

$$J = \frac{1}{32}\pi(d_1^4 - d_2^4) = \frac{1}{8}a(d_1^2 + d_2^2)$$

and for the solid shaft of equal section area,

$$J = \frac{1}{32}\pi d^4 = \frac{1}{8}ad^2 = \frac{1}{8}a(d_1^2 - d_2^2)$$

Therefore, dividing the first by the second, and designating the ratio d_1/d_2 by α , there is found

$$\text{hollow/solid} = (\alpha^2 + 1)/(\alpha^2 - 1)$$

which is the ratio of the stiffness of a hollow shaft to that of a solid one of the same section area. When d_1 is double d_2 , the value of α is 2, and the hollow shaft is about 67 percent stiffer than the solid one.

Shafts of the same material and length are of the same strength when their values of J/c are equal, and of the same stiffness when their values of J are equal. It is easy to show that the percentage of weight saved by using a hollow shaft instead of a solid one is,

$$\text{for equal strength} \quad 100 - 100[(\alpha^4 - \alpha^2)/(\alpha^2 + 1)^2]\dagger$$

$$\text{for equal stiffness} \quad 100 - 100[(\alpha^2 - 1)/(\alpha^2 + 1)]\ddagger$$

in which α is the ratio d_1/d_2 which will be determined by practical considerations concerning ease of manufacture and operation. When $\alpha = 2$, the percentages saved are 21.7 for equal strength and 22.5 for equal stiffness.

Prob. 95. Compare the strengths of two shafts when stressed to their elastic limits; the first shaft is solid, 21 inches in diameter, and has an elastic limit of 25 000 pounds per square inch; the second shaft is hollow, 18 inches outside and 9 inches inside diameter, and its elastic limit is 45 000 pounds per square inch. If the price per pound of the first shaft is 18 $\frac{3}{4}$ cents, what price per pound could one afford to pay for the second shaft?

ART. 96. SHAFT COUPLINGS

At *A* and *B* in Fig. 96 are shown the end and side views of a flange coupling for a shaft, the flanges being connected by bolts. These bolts, in transmitting the torsion from one flange to the other, are subject to shearing stress, and they must be of sufficient strength to safely carry it. This shear does not differ in character from that in the main body of the shaft, and it is the greatest upon the side of the bolt most remote from the axis of the shaft.

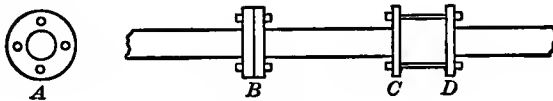

Fig. 96

Let J be the polar moment of inertia of the cross-section of a solid shaft, c its radius, and S the shearing unit-stress on the outer surface. Let J_1 be the polar moment of inertia of the cross-section of the bolts with respect to the axis of the shaft, c_1 the distance from the axis of the shaft to the side of the bolts farthest from the axis, and let the shearing unit-stress on that side be required to be the same as that on the outer surface of the shaft. Then, in order that the bolts may be equal in strength to the shaft, it is necessary that J/c should equal J_1/c_1 . The polar moment of inertia of the section of one bolt with respect to the axis of the shaft is equal to its polar moment with respect to its own axis plus the section area of the bolt into the square of the distance between the two axes.

Let D be the diameter of the shaft, d the diameter of each of the bolts, h the distance of the center of a bolt from the axis of the shaft, and n the number of bolts; then

$$J/c = \frac{1}{8}\pi D^3 \quad J_1/c_1 = n\left(\frac{1}{8}\pi d^4 + \frac{1}{4}\pi d^2 \cdot h^2\right) / \left(\frac{1}{2}d + h\right)$$

and by equating these values there is found

$$D^3(d + 2h) = nd^2(d^2 + 8h^2)$$

which is the necessary relation between the quantities in order

that the bolts may be equal in strength to the shaft, provided the material be the same. From this formula the number of bolts required is easily found when d , h , and D are given.

This formula is an awkward one for determining d , and hence it is often assumed that the shear is uniformly distributed over the bolts, or that $c_1 = h$ and $J_1 = \frac{1}{2}\pi d^2 h^2$. This amounts to the same thing as regarding d as small compared to h , and the expression then reduces to

$$D^3 = 4nhd^2 \quad \text{or} \quad d = \frac{1}{2}(D^3/nh)^{\frac{1}{2}}$$

from which an approximate value of d can be found when the number of bolts is given.

The above supposes the shaft to be solid. When it is hollow, with outside diameter D and inside diameter d_1 , the D^3 in the above expressions is to be replaced by $D^3 - d_1^4/D$.

The case shown at CD in Fig. 96 is one that would not occur in practice, but it is here introduced in order to indicate that the bolts would be subject to a flexural as well as a shearing stress. It is clear that the flexural stress will increase with the length of the bolts, and that they should be greater in diameter than for the case of pure shearing. The flexural stress will also depend upon the work transmitted by the shaft. This case will be investigated in Art. 98 in connection with the discussion of the pin of a crank shaft.

Prob. 96a. A solid shaft 6 inches in diameter is coupled by bolts $1\frac{1}{4}$ inches in diameter with their centers 5 inches from the axis. How many bolts are necessary?

Prob. 96b. A hollow shaft 17 inches in outside and 11 inches in inside diameter is to be coupled by 12 bolts placed with their centers 20 inches from the axis. What should be the diameter of the bolts?

ART. 97. A SHAFT WITH CRANK

A crank pin, CD in Fig. 97, is subject to a pressure W from the connecting rod of the steam engine, this pressure being uniformly distributed over nearly the length of the pin. The pressure varies at different positions in the stroke of the engine, but for

ordinary computations may be taken at from 10 to 20 percent greater than the total mean pressure of the steam on the piston; to this may be added the weight of the connecting and piston rods in case these should be vertical in position.

The maximum pressure W causes a cross-shear in the crank pin at the section C , and it also causes a flexural stress at the end C due to a uniform load over the cantilever CD . These stresses may be computed by the shear and flexure formulas of Art. 41. The compressive or bearing stress upon the pin is usually also to be considered, this being estimated per square unit of diametral area in the same manner as the sidewise pressure on a rivet (Art. 33.).

In the figure the pressure W is shown acting parallel to the crank arm BC , but it acts at all angles to this arm during one revolution of the shaft AB . When it acts at right angles, the crank arm is a cantilever beam, and the maximum flexural stresses which occur at B may be computed by the flexure formula (41). The flexural unit-stresses in both pin and crank arm alternate from tension to compression as the arm revolves, for the pressure W comes on opposite sides of the pin as the piston rod moves forward or backward. On account of these alternating stresses the allowable working unit-stresses should be taken low in designing the pin and crank arm.

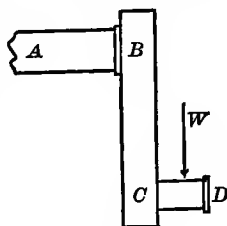

Fig. 97

The shaft, crank arm, and pin are usually forged, the whole being one piece of metal, but for very large shafts the crank arm may be bored to a diameter slightly less than that of the end of the shaft and then shrunk upon it (Art. 32). Sometimes a shaft has a crank arm at each end, it being then called a double-throw crank shaft; in this case the two crank arms are set at right angles to each other, in order that the action of the two pressures W may produce a more uniform twisting moment on the shaft. The largest crank shaft in use was made by the Bethlehem Steel Company in 1905; it is 37 inches in outside and

30 inches in inside diameter, the crank webs are 64 inches long, 49 inches wide and 16 inches thick, and the solid pins are 19 inches in diameter. This double-throw crank shaft is 27 feet long, the two crank pins, webs, and shaft being one piece of steel which was forged from an ingot weighing 308 000 pounds, and the weight of the finished shaft is 86 600 pounds.

Prob. 97a. The crank pin CD in Fig. 97 is 8 inches long and 4 inches in diameter, the pressure W being 60 000 pounds. Compute the bearing unit-stress, the shearing unit-stress, and the flexural unit-stress.

Prob. 97b. Let BC be 14 inches long, 4 inches thick, and 10 inches wide at B . Compute the flexural unit-stress at B when the pressure of 60 000 pounds acts normal to BC .

ART. 98. A TRIPLE-CRANK SHAFT

Double and triple cranks are used when several engines are to be attached to the same shaft, as is usual in ocean steamers. With the triple arrangement the cranks are set at angles of 120 degrees with each other, thus securing a uniform action upon the shaft. Fig. 98 shows one of these cranks, AB and EF being portions of the shaft resting in journal bearings, CD one of the crank pins to which the connecting rod is attached, while BC and DE are the crank arms or webs which are usually shrunk upon the shaft and pins.

The complete investigation of the maximum stresses in such a crank shaft and pin is one of much difficulty. A brief abstract of such an investigation will, however, here be given for the crank pin. There are three cranks, and the one to be considered is the nearest to the propeller, so that the torsion from the other two cranks is transmitted through the pin CD . This steel crank pin is hollow, 18 inches in outer diameter and 6 inches in inner diameter, its length between webs being 24 inches, the thickness of each web 12 inches, and the distance from the axis of the shaft to the center of the pin being 30 inches. The three engines transmit 7 200 horse-power to the shaft EF , of which 4 800 horse-power is transmitted through the shaft AB and through the crank pin CD . The maximum pressure W brought

by the connecting rod upon the crank pin is 156 000 pounds. It is required to determine the stresses when the crank makes 80 revolutions per minute.

The pressure W is distributed over about 17 inches of the length of the pin, so that the bearing compressive stress on the diametral area is $S_1 = 156\ 000 / 17 \times 12 = 765$ pounds per square inch, which is a low and safe value. The shearing unit-stress due to W , which is taken as uniformly distributed over the section area of the pin, is

$$S_2 = 78\ 000 / \frac{1}{4}\pi(18^2 - 6^2) = 345 \text{ pounds per square inch}$$

which is also a low working value for steel.

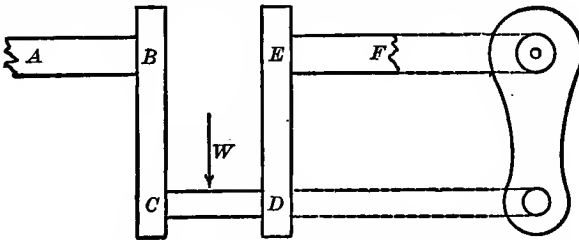

Fig. 98

The shearing stress due to the horse-power transmitted through BC has its greatest value on the side of the pin farthest from the axis. The twisting moment Pp due to this 4 800 horse-power is found from formula (91) to be,

$$Pp = 63\ 000 \times 4\ 800 / 80 = 3\ 782\ 000 \text{ pound-inches}$$

and this is equal to the resisting moment of the crank pin, or to SJ_1/c_1 , in which J_1 is the polar moment of inertia of the cross-section with respect to the axis of the shaft and c_1 is the distance from that axis to the side of the pin where the stress S is to be found. Now, $c = 30 + 9 = 39$ inches, and then $J_1 = 0.0982(18^4 - 6^4) + 0.7854(18^2 - 6^2) \times 39^2$. Hence, from formula (90) there is found,

$$S_3 = 3\ 782\ 000 \times 39 / 354\ 000 = 420 \text{ pounds per square inch}$$

which is the shearing stress due to the transmitted power.

The flexure of the pin due to the torsion carried through it falls under the case discussed in Art. 65. The twisting moment Pp is equivalent to a force P acting at a distance of 30 inches

from the shaft and normal to the crank arms; the value of P is $3\,782\,000/30 = 126\,100$ pounds, and this produces a bending moment in the pin which may be taken as a beam fixed at both ends, while P acts in opposite directions at those ends, as in Fig. 65*a*. Hence there is a bending moment M' at each end, opposite in sign but equal in value, and the moment at any section is $M = M' + Px$; but when $x = l$ the value of M is $-M'$ and therefore $M' = \pm \frac{1}{2}Pl$, which is the maximum bending moment. The flexure formula (41) then gives

$$S_4 = M' \cdot c/I = 63\,000 \times 18 \times 9 / \frac{1}{64} \pi (18^4 - 6^4) = 2\,060$$

which is the flexural stress in pounds per square inch due to the transmission of power through the pin.

All of these stresses are light, but the pin is necessarily made heavier than they would require, on account of the additional stresses due to the shrinking of the web upon the pin. The data here given are not sufficient to determine these shrinkage stresses, but the discussion in Art. 154 indicates that there is a radial compressive unit-stress S_5 brought by the web upon the pin of probably 3 000 pounds per square inch, and that this is accompanied by a tangential compressive unit-stress S_6 of about 4 000 pounds per square inch. These shrinkage stresses occur also in the fillet of the pin on the inside of the web at D , where all the other stresses except S_1 concentrate. In Art. 179 it will be shown how these several values may be combined in order to obtain the final maximum tensile, compressive, and shearing stresses.

Since all these stresses vary in direction and intensity as the shaft revolves, their effect is more injurious than steady stresses, and accordingly the factors of safety should be high, or the working unit-stresses low, in order that the life of the crank pin may not be short (Art. 137). Shocks are also brought upon the shaft of an ocean steamer when the propeller at the stern rises out of the water and falls back again, as it does when great waves cause longitudinal oscillations, and these shocks also require that the working unit-stresses shall be low.

Prob. 98. The shaft EF in Fig. 98 is hollow, the inside diameter being 8 inches and the outside diameter 24 inches. Compute the flexu-

ral unit-stress S when 7 200 horse-powers are transmitted through it while it is making 65 revolutions per minute.

ART. 99. NON-CIRCULAR SECTIONS

When a rectangular bar is subject to torsion the general phenomena are the same as those described in Art. 89, but the distribution of the shearing stresses over the section area is observed to be different from that in a circular section. In Fig. 169*c* is seen a steel rectangular bar, $\frac{1}{2} \times 1\frac{1}{2} \times 8\frac{1}{2}$ inches, which has been twisted in a torsion machine through an angle of 142 degrees. Before the test the surfaces of the bar were blackened and two series of white lines drawn thereon at right angles to each other; the figure plainly shows the distortion of the rectangles into rhombuses, the greatest distortion in the right angles being at the middle of the wide side, while the white lines remain closely perpendicular to the corner lines of the bar. From many experiments of this kind it is concluded, since stresses are proportional to distortions, that the shearing unit-stress at the middle of the wide side is greater than that at the middle of the narrow side of the rectangular bar, and that there are no shearing stresses along the corners.

When lines are ruled upon the surface of a round bar it is observed that the distortion of the angles is the same on all parts of the surface, and hence the shearing unit-stress is uniform over that surface; this is the basis of the torsion formula deduced in Art. 90. For a bar of elliptical section, however, it is observed that the distortion of the angles is greatest on the flatter side of the section; hence the shearing unit-stress is there the greatest, and the torsion formula (90) does not apply to the elliptical bar; in fact, that formula applies only to circular sections, and it should not be used for other sections except for approximate investigations. The correct torsion formulas for elliptical and rectangular sections will now be deduced.

Let Fig. 99*a* represent a section of an elliptical bar which is subject to a twisting moment $P\rho$ from a force P acting in a plane normal to the axis and at a distance ρ from that axis. Let

m be the major axis and n the minor axis of the ellipse, let y and x be the vertical and horizontal coordinates of any point on the circumference of the ellipse with respect to m and n as coordinate axes. Let S_1 and S_2 be the shearing unit-stresses at the extremities of the minor and major axes, and S the shearing unit-stress at the point where coordinates are y and x ; these stresses are tangential to the circumference. Let S' and S'' be the components of S parallel to S_1 and S_2 ; and let χ be the angle which S makes with S_1 ; then $S' = S \cos \chi$ and $S'' = S \sin \chi$, whence $S''/S' = \tan \chi$. The equation of the ellipse is $m^2y^2 + n^2x^2 = \frac{1}{4}m^2n^2$, and by differentiation there is found $\delta y/\delta x = -m^2x/n^2y = \tan \chi$; accordingly $S''/S' = n^2x/m^2y$ and it thus appears that the components S'' and S' are proportional to their distances from the coordinate axes n and m . When the elastic limit of the material is not exceeded, the same relation must hold between the components of the unit-stress at any point within the ellipse, for here, as in the circle, the unit-stresses along any radius vector vary proportionally as their distances from the center.

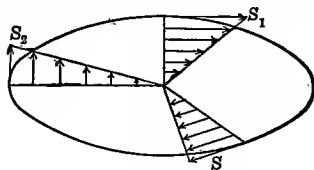

Fig. 99a

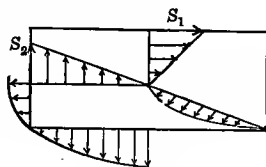

Fig. 99b

Now let y_1 and x_1 refer to any point within the ellipse and let m_1 and n_1 be the axes of an ellipse passing through that point, the ratio m_1/n_1 being equal to m/n . Let S_x and S_y be the components of the unit-stress at that point, S_x being parallel to S_1 and S_y to S_2 ; then also $S_y/S_x = n_1^2x_1/m_1^2y_1$. Let δa be the element of area at the given point; then $S_x y_1 \delta a + S_y x_1 \delta a$ is the resisting twisting moment of the stress on that area, and the sum of all similar expressions for all elements of the area equals the twisting moment, or

$$\sum S_x y_1 \delta a + \sum S_y x_1 \delta a = Pp$$

Substituting in this for S_y its value $S_x \cdot n_1^2 x_1 / m_1^2 y_1$ and then for S_x its value $S' \cdot y_1 / y$, and also for m_1/n_1 its value m/n , the com-

ponent S' is found. Similarly substituting for S_x its value $S_y \cdot m_1^2 y_1 / n_1^2 x_1$ and then for S_y its value $S'' \cdot x_1 / x$, the component S'' is found. In both cases $\Sigma y_1^2 \delta a$ is the moment of inertia I_1 of the area of the ellipse with respect to the major axis m , while $\Sigma x_1^2 \delta a$ is the moment of inertia I_2 with respect to the minor axis n . Thus are found,

$$S' = \frac{P\phi \cdot m^2 y}{m^2 I_1 + n^2 I_2} \quad S'' = \frac{P\phi \cdot n^2 x}{m^2 I_1 + n^2 I_2}$$

which are the components of the shearing unit-stress S at any point on the circumference whose coordinates are y and x . When $y=0$ and $x=\frac{1}{2}m$, the horizontal component S' is 0 and the vertical component S'' becomes S_2 in the figure; when $x=0$ and $y=\frac{1}{2}n$, the vertical component S'' is zero and the horizontal component becomes S_1 in the figure. The ratio S_1/S_2 is hence equal to $m^2 n / m n^2$ or to m/n , that is, the shearing unit-stresses at the ends of the axes are inversely proportional to the lengths of those axes. The greatest unit-stress hence occurs at the ends of the minor axis, while the least unit-stress on the circumference occurs at the ends of the major axis; hence S_1 is the unit-stress to be used. The rectangular moment of inertia of the ellipse with respect to its major axis is $I_1 = \frac{1}{64} \pi m n^3$ and that with respect to the minor axis is $I_2 = \frac{1}{64} \pi m^3 n$ (Art. 43). Substituting these values in the above value of S' and making $y = \frac{1}{2}n$, there results,

$$S_1 = \frac{16P\phi}{\pi m n^2} \quad \text{or} \quad P\phi = \pi m n \frac{1}{8} S_1$$

which are the formulas for discussing a bar of elliptical cross-section under torsion. When $m=n=d$, the ellipse becomes a circle, and the formula reduces to that deduced for the circle in Art. 92.

For the rectangle in Fig. 99*b*, the exact discussion is much more difficult because the stresses are not proportional to their distances from the axis except along the median lines. On any side the stress is greatest at the middle and varies approximately as the ordinates of a parabola toward each corner where it becomes zero; the stress at the middle of the broad side is greater than that at the middle of the narrow side, as in the elliptical section. Let m and n be the long and short sides of the rectangle,

and let x and y be coordinates of any point within the rectangle with respect to axes through the center, x being parallel to m and y to n . Then the above facts of experiment indicate that the variation of stresses throughout the rectangle is closely expressed by

$$S_x = \frac{2S_1 y}{n} \left[1 - \left(\frac{2x}{m} \right)^2 \right] \quad S_y = \frac{2S_2 x}{m} \left[1 - \left(\frac{2y}{n} \right)^2 \right]$$

where S_1 and S_2 are the unit-stresses at the middle of the long and short sides, respectively, and S_x and S_y are the components parallel to S_1 and S_2 of the unit-stress at any point. The fundamental equation between resisting and twisting moment is also the same as before; replacing the sign of summation by that of integration and δa by $\delta x \delta y$, it becomes,

$$\int S_x y \delta x \delta y + \int S_y x \delta x \delta y = P \phi$$

Inserting in this the values of S_x and S_y and integrating, first between the limits $+\frac{1}{2}n$ and $-\frac{1}{2}n$ for y , and second between the limits $+\frac{1}{2}m$ and $-\frac{1}{2}m$ for x , it becomes $\frac{1}{3}mn(S_1 n + S_2 m) = P \phi$. Now, as in the ellipse, S_1/S_2 equals m/n , and accordingly $S_2 m$ equals $S_1 n$; whence, since S_1 is the greatest unit-stress,

$$S_1 = \frac{3}{8} P \phi / mn^2 \quad \text{or} \quad P \phi = \frac{8}{3} mn^2 S_1$$

are the formulas for discussing rectangular bars under torsion. Apply to a square bar of side d by making mn^2 equal to d^3 .

A comparison of the strength of solid round and square shafts is now readily made from the values of the twisting moments derived in Art. 92 and in the preceding paragraph:

$$\text{for a round shaft,} \quad P \phi = \frac{1}{4} \pi S d^3 = 0.1964 S d^3$$

$$\text{for a square shaft,} \quad P \phi = \frac{8}{3} S d^3 = 0.2222 S d^3$$

and accordingly the strength of a square shaft of side d is 13 percent greater than that of a round shaft of diameter d , the shearing unit-stress being the same in the two cases. When power is transmitted by a square shaft, $P \phi$ is to be replaced by $63.030 H/n$ for English measures and then are found

$$S = 284.000 H / nd^3 \quad \text{or} \quad d = 65.7 (H/nS)^{\frac{1}{3}}$$

which are the formulas for the investigation and design of solid square shafts similar to those of (92) for solid round shafts.

The angle of twist produced in a non-circular section by a given twisting moment cannot be deduced by the method given in Art. 93 for round shafts, on account of the irregular distribution of stresses. The investigations of Saint Venant, who was the first to establish the correct theory of torsion, give the following value for the angle of twist for a square shaft, that for the round shaft being derived from Art. 93:

$$\begin{array}{ll} \text{for a round shaft,} & \phi = 10.18P\phi \cdot l/Fd^4 \\ \text{for a square shaft,} & \phi = 7.11P\phi \cdot l/Fd^4 \end{array}$$

and hence the angle of twist of a round shaft is 43 percent greater than for a square one. These values of ϕ are in radians; when the angle is desired in degrees, it should be remembered that one radian is equivalent to 57.3 degrees.

All the formulas of this article are valid only when the greatest shearing unit-stress does not exceed the elastic limit of the material. The formula $S = \frac{3}{2}P\phi/mn^2$ may, however, be used to compute the so-called torsional modulus of rupture or torsional strength when a rectangular bar is ruptured by torsion, n being the short side of the rectangle. When rupture occurs in the twisting of such a bar, it usually begins at the middle of the flat side, so that even in this extreme case there is little shearing stress on the corners. Cracks occurring on the corners are to be attributed to tensile stresses which accompany the elongation due to the change of a straight line into a helix. For example, the square steel bar in Fig. 169c was 11 $\frac{3}{4}$ inches long between the jaws of the torsion machine, and this length was not increased by the twist of 900 degrees. The side of the square being 0.75 inches, the length of its diagonal is 1.06 inches, the length of a circumference of 900 degrees described by the corner is 8.33 inches, and the length of the helix is 14.40 inches; hence the increase in length of the corner line was 2.65 inches and the percentage of elongation was nearly 23 percent, which is less than the ultimate elongation. The specimen broke by shearing at one end under a twisting moment of 5 850 inch-pounds, so that the computed torsional strength of the steel is $S = 9 \times 5\ 850 / 2 \times 0.75^3 = 62\ 400$ pounds per square inch.

Prob. 99*a*. Check the computations in the last paragraph.

Prob. 99*b*. Compare the strength of a round shaft with that of a square one having the same area of cross-section.

Prob. 99*c*. A square wooden shaft for a water wheel is 12 inches square and transmits 36 horse-powers at 9 revolutions per minute. Compute its factor of safety.

Prob. 99*d*. The rectangular bar of medium steel in Fig. 169*c* was twisted through an angle of 28.5 degrees by a twisting moment of 2 800 inch-pounds, the length of the bar being $8\frac{1}{2}$ inches, its thickness $\frac{1}{2}$ inch, and its width $1\frac{1}{2}$ inches. Compute the shearing unit-stress for these data, and determine whether or not the shearing elastic limit of the material was exceeded.

CHAPTER XI

APPARENT COMBINED STRESSES

ART. 100. STRESSES DUE TO TEMPERATURE

Several axial loads produce the same unit-stress in a bar as a single load equal to their algebraic sum and the change of length which is that due to this load. When the bar is thus stressed at a certain temperature, a change in temperature usually causes the existing stress to become greater or less. When a bar is free to expand or contract under a rise or fall of temperature, there occurs a change of length which is unaccompanied by internal stress, for in this case there is no external force and stress is an internal resistance to an applied external force. If this change of length is, however, prevented from occurring by fastening the ends of the bar, there is produced an internal stress which is the same as that which would be caused by an external force which would shorten or lengthen the free bar the same amount that it has expanded or contracted. For example, let a free steel bar 100 inches long become 99.9 inches long under a certain fall of temperature, then no internal stress is caused by this change in length; to bring this bar back to its original length, there must be effected the unit-elongation $0.1/100 = 0.001$ and Art. 10 shows that this will require a tension of $0.001 \times 30\,000\,000 = 30\,000$ pounds per square inch. Hence, if this bar is prevented from shortening under the given fall of temperature, a tensile unit-stress of 30 000 pounds per square inch is produced in every cross-section.

Let ϵ be the change per unit of length which occurs when a bar is free to expand or contract, η the coefficient of linear expansion or change per unit of length for a rise or fall of one degree Fahrenheit, and t the number of degrees of rise or fall; also let S be the unit-stress which will occur if the bar is prevented from expanding or contracting, and E be the modulus of elasticity of

the material. Then from the preceding paragraph and from Art. 9,

$$\epsilon = \eta t \qquad S = \epsilon E \qquad S = \eta t E \qquad (100)$$

It is thus seen that the unit-stress due to change of temperature is independent of the length of the bar; if a is the section area of the bar, the total stress in each section due to the change in temperature is aS .

The following are average values of the coefficients of linear expansion for one degree of the Fahrenheit scale:

for brick and stone,	$\eta = 0.000\ 0050$
for cast iron,	$\eta = 0.000\ 0062$
for wrought iron,	$\eta = 0.000\ 0067$
for steel,	$\eta = 0.000\ 0065$

From these coefficients the change per unit of length due to a rise or fall of t degrees is readily computed or the unit-stress S may be directly found. This temperature stress is to be added to or subtracted from the tensile or compressive stress due to the applied forces on the bar.

As an example consider a wrought-iron tie rod 20 feet in length and 2 inches in diameter which is screwed up to a tension of 9 000 pounds in order to tie together two walls of a building. Let it be required to find the stress in the rod when the temperature falls 10 degrees Fahrenheit. Here,

$$S = 0.000\ 0067 \times 10 \times 25\ 000\ 000 = 1\ 675 \text{ pounds}$$

and the stress due to change of temperature is $3.14 \times 1\ 675 = 5\ 200$ pounds, so that the total tensile stress in the bar becomes $9\ 000 + 5\ 200 = 14\ 200$ pounds. For a rise of 10 degrees Fahrenheit, the tensile stress in the bar becomes $9\ 000 - 5\ 200 = 3\ 800$ pounds.

It is seen from the above that the unit-stress caused in a steel bar by a change of one degree Fahrenheit is about 200 pounds per square inch, so that a change of 100 degrees might cause a stress of 20 000 pounds per square inch if no provision were made for allowing the bar to change its length. Steel bridges usually rest on rollers at one end so that change in length may occur under change of temperature and thus stresses due to

temperature be prevented. When railroad rails are laid in cold weather, it is customary to leave the ends about $\frac{1}{4}$ inch apart, so that there may be room for expansion when the warm weather comes; the holes in webs of the rails, through which bolts pass to connect the splice bars, are made oval instead of round so that the rails may be free to expand and contract.

Prob. 100. What is the change in length of a steel railroad rail 60 feet long when the temperature rises from -10 to $+80$ degrees Fahrenheit? If the rail weighs 95 pounds per yard, what force is required to prevent this expansion, and what compressive unit-stress will it cause in the rail?

ART. 101. BEAMS UNDER AXIAL FORCES

A normal stress is one acting normally to the section area of a bar, and this must be either tensile or compressive (Art.1). When several applied axial forces act upon a bar each produces a stress on the section area and the sum of these stresses must equal the total load. Hence the combination of normal stresses is made by simple addition, if all are tensile or all are compressive; when some are tensile and others compressive, their algebraic sum is to be taken.

A beam under transverse loads has normal stresses of tension on one side of its neutral surface and normal stresses of compression on the other side (Art. 39). When the beam is under an axial tension P which is uniformly distributed over the section area a , the unit-stress P/a is to be added to each of the flexural tensile unit-stresses and be subtracted from each of the flexural compressive unit-stresses. Thus, if the unit-stresses due to the flexure on the tensile and compressive sides of the beam are S_1 and S_2 , then $S_1 + P/a$ is the tensile unit-stress due to flexure and longitudinal tension, while $S_2 - P/a$ is the compressive unit-stress due to flexure and axial tension.

An approximate method of finding S_1 and S_2 is by mean of the flexure formula (41), which is applied to the transverse loads just as if the axial tension were not acting. For example, let it be required to find the factor of safety of a 12-inch I beam

of 6 feet span, weighing 55 pounds per linear foot, which carries a uniform load of 1 200 pounds besides its own weight, when subject to an axial tension of 80 000 pounds. The flexure formula is $S_1 \cdot I/c = M$; from Table 6 the section factor I/c is 53.5 inches³; from Art. 38 the bending moment M is $1\ 530 \times 6/8 = 1\ 147.5$ pound-feet; hence the tensile unit-stress on the lower side of the simple beam is $S_1 = 257$ pounds per square inch. Table 6 gives the section area $a = 16.18$ square inches, and hence the unit-stress due to the axial tension is $P/a = 80\ 000/16.18 = 4\ 940$ pounds per square inch. Hence on the lower side of the beam, the total tensile stress is $260 + 4\ 940 = 5\ 200$ pounds per square inch, and the factor of safety is $60\ 000/5\ 200 = 11\frac{1}{2}$. On the upper side of the beam, the stress is tensile, since P/a is greater than S_2 , and its value is $4\ 940 - 260 = 4\ 680$ pounds per square inch.

When the axial force on the beam is compression, a similar approximate method may be followed, the compressive unit-stress S_1 on the concave side being found from the flexure formula, while the unit-stress due to the load is found from P/a , if the beam is short, or from the column formula (80) if its length exceeds ten or twelve times its least thickness.

A rafter of a roof is a case of combined compression and flexure, for a rafter is under compression from the forces that act upon its ends and under flexure from its weight and that of the roof covering. In many cases the approximate method here outlined is sufficient for its investigation. Let the section of

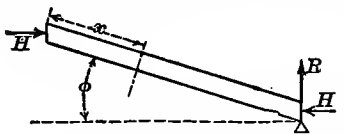

Fig. 101.

the rafter be rectangular, b being its width, d its depth, l the length, w the uniform load per linear unit, and ϕ the angle of inclination. To find the horizontal reaction

H , the center of moments is taken at the lower end, and,

$$H \cdot l \sin\phi = wl \cdot \frac{1}{2}l \cos\phi \quad \text{whence } H = \frac{1}{2}wl \cot\phi$$

For any section area at the distance x from the upper end of the rafter, the flexure formula gives the flexural unit-stress,

$$S_1 = \frac{6M}{bd^2} = \frac{6(Hx \sin\phi - \frac{1}{2}wx^2 \cos\phi)}{bd^2}$$

and the uniform compressive unit-stress is,

$$\frac{P}{a} = \frac{H \cos\phi + wx \sin\phi}{bd}$$

The total compressive unit-stress on the upper fiber hence is,

$$S = S_1 + P/a = \frac{3w \cos\phi}{bd^2} (lx - x^2) + \frac{wl \cot\phi \cos\phi}{2bd} + \frac{wx \sin\phi}{bd}$$

By the usual method this is found to be a maximum when

$$x = \frac{1}{2}l + \frac{1}{6}d \tan\phi$$

and substituting this, the maximum unit-stress is,

$$S = \frac{3wl^2 \cos\phi}{4bd^2} + \frac{wl \operatorname{cosec}\phi}{2bd} + \frac{w \sin\phi \tan\phi}{12b}$$

which formula may be used to investigate or to design common rafters subject to uniform loads.

In any inclined rafter, let P denote all the load above a section distant x from the upper end. Then reasoning as before the greatest unit-stress for that section is found to be,

$$S_x = \frac{Mc}{I} + \frac{P \sin\phi}{a} + \frac{H \cos\phi}{a}$$

from which S_x may be computed for any given case.

Prob. 101*a*. Find the size of a square wooden simple beam of 12 feet span to carry a load of 300 pounds at the middle when it is also subject to a longitudinal tension of 2 000 pounds, the allowable tensile stress being 1 000 pounds per square inch.

Prob. 101*b*. A roof with two equal rafters is 40 feet in span and 15 feet in height. The wooden rafters are 4 inches wide and each carries a load of 450 pounds at the middle. Find the depth of the rafter so that S may be 700 pounds per square inch.

ART. 102. FLEXURE AND COMPRESSION

Let a beam be subject to flexure by transverse loads and also to an axial compression in the direction of its length. If the longitudinal compression is not large, the combined maximum stress due to flexure and compression may be computed by the approximate method of Art. 101. It is clear, however, that if the compression is large the deflection of the beam will be

increased by it, and hence the effective bending moment and maximum fiber stresses will be greater than given by that method. A closer approximation will now be established.

Let P be the axial compressive force and M the bending moment of the flexural forces. Let M_1 be the actual bending moment for the dangerous section where the actual deflection is f_1 ; this is greater than M , on account of the moment Pf_1 of the force P , or $M_1 = M + Pf_1$. Now the maximum fiber unit-stress S_1 which results from this moment M_1 is, from (41),

$$S_1 = M_1 \cdot c/I = (M + Pf_1)c/I$$

where I is the moment of inertia of the cross-section and c the distance from the neutral axis to the remotest fiber on the compressive side. The value of f_1 may be expressed in terms of S_1 , regarding f_1 to vary with S_1 in the same manner as for a beam subject to no axial compression. Inserting then for f_1 its value from Art. 56, and solving for S_1 , gives,

$$S_1 = \frac{Mc}{I} \left/ \left(1 - \frac{\alpha P l^2}{\beta EI} \right) \right. \quad (102)$$

where α and β are numbers that depend upon the arrangement of the ends and the kind of loading of the beam; for a simple beam uniformly loaded the value of β/α is 9.6; for a simple beam with load at the middle β/α is 12.

The maximum compressive unit-stress on the concave side of the beam is $S = S_1 + P/a$. For example, let a simple wooden beam 8 feet long, 10 inches wide, and 9 inches deep be under an axial compression of 40 000 pounds, while at the same time it carries a total uniform load of 4 000 pounds. Here $M = \frac{1}{8}Wl = 48\,000$ pound-inches, $c = 4\frac{1}{2}$ inches, $I = \frac{1}{12}bd^3 = 607\frac{1}{2}$ inches⁴, $l = 96$ inches, $P = 40\,000$ pounds, $\alpha = 8$, $\beta = \frac{3\beta_0 l^2}{EI}$, and $E = 1\,500\,000$ pounds per square inch. Inserting these values in the formula, the value of Mc/I is 356, and then the final flexural stress S_1 is found to be 371 pounds per square inch. The compressive unit-stress due directly to P is $P/a = 40\,000/90 = 444$, so that the total stress $S = 371 + 444 = 815$ pounds per square inch.

Another method, which has a more satisfactory theoretical basis, is to consider the flexural stress due to P as resulting from

its eccentricity with respect to the section at the middle of the beam. Under the action of its own weight a simple beam has the deflection f ; this is increased by the action of the eccentric load, and from Art. 87, the total deflection is $f \sec \theta$ where θ denotes the quantity $\frac{1}{2}(P^2/EI)^{\frac{1}{2}}$ for a beam with supported ends. As before, the total flexural unit-stress S_1 is given by $(M + Pf_1)c/I$, in which f_1 is to be replaced by $f \sec \theta$; also replacing I by ar^2 , where r is the radius of gyration of the section in the plane of bending, the total flexural unit-stress S_1 at the middle of the concave side of the beam is,

$$S_1 = \frac{Mc}{I} + \frac{P}{a} \frac{cf}{r^2} \sec \theta \tag{102}'$$

in which θ has the values given in Art. 87 for different arrangements of the ends of the beam; $\sec \theta$ can be found from a trigonometric table or from the series in Art. 87.

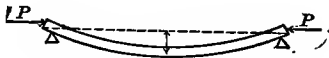

Fig. 102a

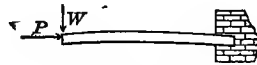

Fig. 102b

To illustrate this method, let the data of the above numerical example be again used. The value of Mc/I is 356 pounds per square inch and this is the flexural unit-stress due to the uniform load alone. The last term of the second member gives the flexural unit-stress due to the moment of P ; here $c = 4.5$ inches, from Art. 55 the deflection due to W is $f = 5Wl^3/384EI = 0.0506$ inches, $r^2 = 607.5/90 = 6.75$ inches², $\theta = \frac{1}{2}(P^2/EI)^{\frac{1}{2}} = 0.3184$ radians = $18^\circ 15'$, $\sec \theta = 1.053$, and lastly $(P/a)(cf/r^2) \sec \theta = 16$ pounds per square inch. The total flexural stress S_1 is then $356 + 16 = 372$ and total compressive stress S is $372 + 444 = 816$ pounds per square inch, which is practically the same as that previously found. The two methods give, in fact, closely the same results for the common cases which occur in practice.

While the above methods are satisfactory in regard to numerical results, a more exact method of dealing with combined flexure and compression is by help of the elastic curve. For the common case of a simple beam loaded uniformly with w per linear unit

and under the longitudinal compression P , the bending moment for any section distant x from the left end of the beam is $\frac{1}{2}wlx - \frac{1}{2}wx^2 + Py$, and the differential equation of the elastic curve of the beam is,

$$EI \frac{\partial^2 y}{\partial x^2} = -\frac{1}{2}wlx + \frac{1}{2}wx^2 - Py$$

where the negative sign of the moment is used because of the theoretic requirement that y and the second derivative must have opposite signs when the curve is concave to the axis of x . By two integrations there is found,

$$y = -\frac{wlx}{2P} + \frac{wx^2}{2P} + \frac{wEI}{P^2} \left(\frac{\cos(2x-l)\theta/l}{\cos\theta} - 1 \right)$$

in which, as before, θ is an abbreviation for $\frac{1}{2}(Pl^2/EI)^{\frac{1}{2}}$. In this equation of the elastic curve, let $x = \frac{1}{2}l$, then $y = f_1$ and then,

$$P^2 f_1 = -\frac{1}{8}wl^2 P + wEI(\sec\theta - 1)$$

which gives the deflection of the beam due to both the uniform load and the longitudinal compression. Inserting the value of the deflection f_1 in the expression for S_1 at the beginning of this article, there is found,

$$S_1 = (wcE/P)(\sec\theta - 1) \quad (102)''$$

as the flexural unit-stress at the middle of the concave side.

To illustrate this method let the data of the above numerical example be again used. Here $w = 4000/96$ pounds per linear inch, and the other quantities as before, also $\sec\theta = 1.0530$; and then (102)'' gives $S_1 = 373$, whence $S = 373 + 444 = 817$ pounds per square inch, which is practically the same as found by the other methods. The rough method of Art. 101 gives $S = 800$ pounds per square inch, and in many cases this method may be used to obtain results which are sufficiently precise.

When $w = 0$ in formula (102)'', the case is that of a column under the axial load P_1 and both f_1 and S_1 are zero when P is less than the value given by Euler's formula (Art. 78), and indeterminate when P reaches that value. On the other hand, when $P = 0$, the case is that of a simple beam uniformly loaded, and it may be shown that the above formula for f_1 will reduce to $5wl^4/384EI$, while that for S_1 will reduce to $\frac{1}{8}wl^2c/I$.

Prob. 102*a*. Prove, by using the method of the differential calculus for evaluating indeterminate quantities, that the statement in the last sentence is correct.

Prob. 102*b*. A wooden cantilever beam, 10 inches wide and 4 feet long, carries a uniform load of 500 pounds per foot and is subjected to a longitudinal compression of 40 000 pounds. Find the depth of the beam so that the maximum compressive unit-stress may be about 800 pounds per square inch.

ART. 103. FLEXURE AND TENSION

Let a beam be subject to flexure by transverse loads and then to a tension in the direction of its length. The effect of the tension is to decrease the deflection from f to f_1 , and thus also the tensile flexural stress. If M is the bending moment of the transverse loads, and M_1 that of the combined flexure and tension, then $M_1 = M - Pf_1$. Let S_1 be the resulting flexural unit-stress on the fiber most remote from the neutral surface on the tensile side; then formula (102) gives S_1 , if the minus sign in the denominator is changed to plus. Accordingly,

$$S_1 = \frac{Mc}{I} \left/ \left(1 + \frac{\alpha Pl^2}{\beta EI} \right) \right. \quad (103)$$

and $S_1 + P/a$ is the total unit-stress on the convex side of the beam resulting from the combined flexure and tension.

As an example, take a steel eye-bar 18 feet long, 1 inch thick, and 8 inches deep, under a longitudinal tension of 80 000 pounds, E being 29 000 000 pounds per square inch. The weight of the bar is 490 pounds, and $M = \frac{1}{8} \times 490 \times 18 \times 12 = 13\,230$ pound-inches. Also $c = 4$ inches, $I = 42.67$ inches⁴, $\beta/\alpha = 9.6$, $P = 80\,000$ pounds, $l = 216$ inches. Then the value of Mc/I is 1 240, and the flexural tensile stress S_1 is 943 pounds per square inch. Finally, the total tensile stress on the convex side at the middle of the beam is $S = 943 + 10\,000 = 10\,943$ pounds per square inch.

Formula (102)' also applies to combined flexure and tension by changing the sign of P from plus to minus. Here θ becomes imaginary and the circular secant becomes the hyperbolic secant

which is designated by $\operatorname{sech} \theta$. Then,

$$S_1 = \frac{Mc}{I} - \frac{P}{a} \cdot \frac{cf}{r^2} \operatorname{sech} \theta \quad (103)''$$

in which $\operatorname{sech} \theta$ may be computed from $2/(e^\theta + e^{-\theta})$, where e is the base of the Napierian system of logarithms and θ denotes the real positive number $\frac{1}{2}(Pl^2/EI)^{\frac{1}{2}}$. For instance, let the data of the last paragraph be again considered. The value of Mc/I is 1240 pounds per square inch, which is the flexural unit-stress due to uniform load alone. Also $c = 4$ inches, $r^2 = 42.67/8 = 5.334$ inches, $f = 5WB^3/384EI = 0.052$ inches, $\theta = \frac{1}{2}(Pl^2/EI)^{\frac{1}{2}} = 0.868$, $e^\theta = 2.718^{0.868} = 2.383$, $e^{-\theta} = 1/e^\theta = 0.420$, $\operatorname{sech} \theta = 2/2.803 = 0.714$; then $P/a = 10000$ pounds per square inch, $cf/r^2 = 0.039$, and $(P/a)(cf/r^2) \operatorname{sech} \theta = 278$ pounds per square inch, which is the flexural stress due to the moment of P . Lastly, the total tensile stress on the convex side of the middle of the eye-bar is $S = 1240 - 278 + 10000 = 10960$ pounds per square inch.

Formula (102)'' also applies to a beam uniformly loaded and under the tension P by reversing the sign of P , and thus,

$$S_1 = (wEI/P)(1 - \operatorname{sech} \theta) \quad (103)'''$$

where θ is the number $\frac{1}{2}(Pl^2/EI)^{\frac{1}{2}}$ when the ends of the beam are supported. For the above eye-bar, $\operatorname{sech} \theta = 0.714$; also $w = 490/216$ pounds per linear inch. Then the formula gives $S_1 = 941$ for the flexural unit-stress, so that the total compressive unit-stress is $S = 941 + 10000 = 10941$ pounds per square inch.

The three methods hence give numerical results which are essentially the same for all practical purposes, but the first one is the most convenient in computation and hence is generally preferable. Formula (103) applies to all kinds of loading and to all arrangements of ends, as also does (103)'; but (103)'' applies only to uniform load and for this case it is theoretically more correct than the other formulas.

Since many students will here meet with hyperbolic functions for the first time, it may be explained that they are closely analogous to circular trigonometric functions. For circular functions $\cos^2 \theta + \sin^2 \theta = 1$, but for hyperbolic functions $\cosh^2 \theta - \sinh^2 \theta = 1$.

The value of $\cos\theta$ is $\frac{1}{2}(e^{i\theta} + e^{-i\theta})$, in which e is the Naperian base 2.71828 and i is the square root of -1 ; the value of $\cosh\theta$ is given by the simpler expression $\frac{1}{2}(e^\theta + e^{-\theta})$. The reciprocal of $\cos\theta$ is $\sec\theta$ and that of $\cosh\theta$ is $\operatorname{sech}\theta$. Hyperbolic functions are of great importance in the theory of electricity and in other discussions of applied mechanics; a table of values of such functions may be found in Merriman and Woodward's Higher Mathematics (New York, 1898).

Prob. 103*a*. A wooden cantilever beam, $3 \times 4 \times 36$ inches, has a load of 650 pounds at the end and is under the longitudinal compression of 4 500 pounds. Compute the maximum compressive unit-stress.

Prob. 103*b*. When the above cantilever beam is under the longitudinal tension of 4 500 pounds, compute the maximum unit-stress due to it and the load of 650 pounds at the end.

ART. 104. ECCENTRIC AXIAL FORCES ON BEAMS

In the three preceding articles the axial forces applied to the beam have been supposed to act at the centers of gravity of the end sections, so that the stresses due to them would be uniformly distributed over every section area were it not for the deflection of the beam. Sometimes, however, these axial forces are applied eccentrically at the ends, as shown in the following figures, Fig. 104*a* representing a compression applied through pins which also serve as supports for the beam, and Fig. 104*b* representing a tension applied in a similar way. In the first figure the longitudinal compressive forces P are applied below the centers of gravity of the end sections, this being done in order that the moment of P may tend to decrease the deflection of the beam instead of increasing it as is the case when they are applied axially at the ends. It is required to find the amount of this eccentricity so that the unit-stress S at the middle of the beam shall be uniform and equal to P/a over the entire cross-section.

When the stress is uniform over the section at the middle of the beam, there can be no flexural stresses in that section and hence no bending moment. To insure this condition, it may be considered, as an approximation, that the moment of P should

be equal to the moment M of the transverse loads. Let p be the distance of P below the center of gravity of the end sections in Fig. 104a or above it in Fig. 104b. Then when $Pp=M$ there is no bending moment at the middle; accordingly the required eccentricity is $p=M/P$.

For example, take the steel upper chord of a bridge which has a length of 30 feet between the pins at its ends. The section is made up of two channels and a plate, as in Fig. 76c, the section area being 20.5 square inches and its moment of inertia 742 inches⁴. This chord is subject to a longitudinal compression of 168 000 pounds, and it is required to find the distance p below the neutral axis at the ends where the centers of the pins should be located. The weight of the beam is 2 090 pounds, and, taking it as supported at the ends, the moment due to its weight is $M = \frac{1}{8}Wl = 94\ 000$ pound-inches. Then the centers of the pins must be at the distance $p = 94\ 000/168\ 000 = 0.56$ inches below the axis of the chord in order that no flexural stresses may exist. The compressive stress over the middle section is then uniform and equal to $168\ 000/20.5 = 8\ 200$ pounds per square inch.

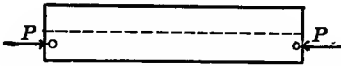

Fig. 104a

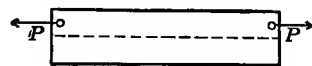

Fig. 104b

The above method is not exact, because it takes no account of the stiffness of the beam and gives the same results for all beams of the same weight. A better method may be derived by considering the beam to have the deflection f before the eccentric load P is applied. Then for compression p must be greater than f and the moment $P(p-f)$ should equal M ; for tension the moment $P(p+f)$ is to be equal to M . Accordingly,

$$p = \frac{M}{P} + f \qquad p = \frac{M}{P} - f \qquad (104)$$

the first of which applies to compression and the second to tension. Hence values of p computed from these formulas will be greater for compression and less for tension than those found from the preceding method.

Using the data of the above chord member while it is under the longitudinal compression of 168 000 pounds, the deflection due to its own weight is $f = 5Wl^3/384EI = 0.057$ inches, and $M/P = 0.56$ inches as before; then the required eccentricity is $p = 0.56 + 0.06 = 0.62$ inches. This same section might serve for a lower chord under a tension of 168 000 pounds, in which case the second formula given $p = 0.56 - 0.06 = 0.50$ inches for the eccentricity. These values are more reliable than the eccentricity 0.56 inches which preceding method gives for both compression and tension.

Prob. 104a. Compute the eccentricity p that is required for the wooden beam which is discussed in Art. 102.

Prob. 104b. Compute the eccentricity p that is required for the eye-bar of Art. 103 in order that there may be little or no flexural stress at the middle.

ART. 105. SHEAR AND AXIAL STRESS

Let a bar having the section area a be subjected to the longitudinal tension or compression P , and at the same time to a shear V at right angles to its length. The axial unit-stress on the section area is P/a , which may be designated by S , and the shearing unit-stress is V/a , which may be denoted by S_s . It is required to find the maximum unit-stresses produced by the combination of S and S_s . In the following demonstration S will be regarded as a tensile unit-stress, although the reasoning and conclusions apply equally well when it is compressive.

Consider an elementary cubic particle, with edges one unit in length, acted upon by the horizontal normal unit-stress S and by the vertical shearing unit-stresses S_s and S_s , as shown in Fig. 105a. These forces are not in equilibrium unless a horizontal couple be applied as in the figure, each of the forces of this couple being equal to S_s . Therefore at every point of a body under vertical shear, there exists a horizontal shearing unit-stress equal to the vertical shearing unit-stress. Heretofore only one of these shearing stresses has been noted, namely, that which is parallel to the applied external shear, but it is now seen that this is always

accompanied by another shearing stress. For example, at any point in a beam where there is a vertical shearing unit-stress V/a , there is also found a horizontal shearing unit-stress of the same intensity. Similarly, Fig. 90 shows the shearing stresses normal to the radius of a shaft under torsion, but there are also shearing stresses parallel to the radius which have the opposite direction of rotation.

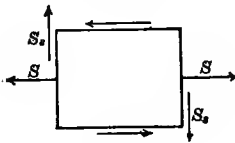

Fig. 105a

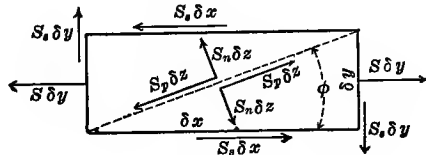

Fig. 105b

Let the parallelepipedal element in Fig. 105b have the length δx , the height δy , the diagonal δz , and a width of unity normal to the plane of the paper. The tensile force $S \cdot \delta y$ tends to pull it apart longitudinally. The vertical shear $S_v \cdot \delta y$ tends to cause rotation and this is resisted by the horizontal shear $S_s \cdot \delta x$. These forces may be resolved into components normal and parallel to the diagonal δz , as shown in the figure. The components normal to the diagonal form normal tensile force $S_n \cdot \delta z$, and those parallel to the diagonal form a shearing force $S_p \cdot \delta z$, where S_n and S_p are the normal tensile and the shearing unit-stresses upon and along the diagonal. It is required to find the maximum values of S_n and S_p due to the given unit-stresses S and S_s .

Let ϕ denote the angle between δx and δz . Resolving each of the given forces in directions perpendicular and parallel to the diagonal, and taking their sum, there results,

$$S_n \delta z = S \cdot \delta y \cdot \sin \phi + S_s \cdot \delta x \cdot \sin \phi + S_s \cdot \delta y \cdot \cos \phi$$

$$S_p \delta z = S \cdot \delta y \cdot \cos \phi + S_s \cdot \delta x \cdot \cos \phi - S_s \cdot \delta y \cdot \sin \phi$$

Since $\delta x = \delta z \cdot \cos \phi$ and $\delta y = \delta z \cdot \sin \phi$, these equations reduce to

$$S_n = \frac{1}{2} S (1 - \cos 2\phi) + S_s \sin 2\phi$$

$$S_p = \frac{1}{2} S \sin 2\phi + S_s \cos 2\phi$$

By differentiating each of these with respect to ϕ and equating each derivative to zero, it is found that,

S_n is a maximum or minimum when $\cot 2\phi = -\frac{1}{2}S/S_s$
 S_p is a maximum when $\tan 2\phi = +\frac{1}{2}S/S_s$

Expressing $\cos 2\phi$ and $\sin 2\phi$ in terms of $\cot 2\phi$ and $\tan 2\phi$ and inserting their values in the expressions for S_n and S_p , the following important results are obtained:

$$\max S_n = \frac{1}{2}S \pm (S_s^2 + (\frac{1}{2}S)^2)^{\frac{1}{2}} \quad \max S_p = (S_s^2 + (\frac{1}{2}S)^2)^{\frac{1}{2}} \quad (105)$$

These formulas apply when S is either tension or compression. When S is tension the plus sign before the radical is to be used to find the maximum tensile unit-stress S_n , while the minus sign gives the maximum compressive unit-stress S_n .

For example, take a bolt one inch in diameter which is subject to a longitudinal tension of 5 000 pounds and at the same time to a cross-shear of 3 000 pounds. Here $S = 6\,366$ pounds per square inch and $S_s = 3\,820$ pounds per square inch. Then $S_n = +8\,155$ pounds per square inch, and $S_n = -1\,790$ pounds per square inch for the minimum tensile or maximum compressive stress, while $S_p = 4\,970$ is the maximum shearing unit-stress; these are the greatest normal and shearing stresses due to the combination of S and S_s . The directions which these maximum stresses make with the axis of the bolt are found by using the values of $\cot 2\phi$ and $\tan 2\phi$ deduced above. For S_n the value of $\cot 2\phi$ is $-3\,183/3\,820 = -0.833$, whence $\phi = 64^\circ 53'$ or $\phi = 154^\circ 53'$, the former being the inclination of the plane against which the maximum tensile stress sets and the latter being its inclination for the maximum compressive stress; these two planes are at right angles to each other. For S_p the value of $\tan 2\phi$ is $+0.833$, whence $\phi = 19^\circ 53'$ or $\phi = 109^\circ 53'$, these being the directions of the planes along which the maximum shearing stresses act; these directions bisect those of the planes upon which the normal stresses are the greatest.

When S_s equals zero the case is that of simple tension or compression, and $\max S_n = S$, while $\max S_p = \frac{1}{2}S$ as previously shown in Art. 6. Here $\cot 2\phi = -\infty$ or $\phi = 0^\circ$; also $\tan 2\phi = \infty$, and $\phi = 45^\circ$ or $\phi = 135^\circ$ so that the maximum shearing stresses make angles of 45° with the direction of the axial tension or compression.

Prob. 105. A bolt $\frac{3}{4}$ inch in diameter is subjected to a tension of 2 000 pounds and at the same time to a cross shear of 3 000 pounds. Find the maximum tensile and shearing unit-stresses, and the directions they make with the axis of the bolt.

ART. 106. COMBINED FLEXURE AND TORSION

This case occurs when a horizontal shaft for the transmission of power is loaded with weights. Let S be the greatest flexural unit-stress computed from (41) and S_s the torsional shearing unit-stress computed from (90) or by the special equations of Arts. 91 and 92. Then, according to the last article, the resultant maximum unit-stresses are,

$$\max S_n = \frac{1}{2}S + \sqrt{S_s^2 + \left(\frac{1}{2}S\right)^2} \qquad \max S_p = \sqrt{S_s^2 + \left(\frac{1}{2}S\right)^2}$$

the first of which gives the greatest tensile or compressive unit-stress on the lower or upper surface of the shaft, while the second gives the greatest shearing unit-stress. For wrought iron or steel it is usually necessary to regard only the first of these unit-stresses, but for timber the second should also be kept in view.

For example, let it be required to find the maximum unit-stresses for a horizontal steel shaft, 3 inches in diameter and 12 feet between bearings, which transmits 40 horse-power while making 120 revolutions per minute, and upon which a load of 800 pounds is brought by a belt and pulley at the middle. Taking the shaft as fixed over the bearings, the flexure formula (41) gives for the unit-stress of tension or compression,

$$S = M \cdot c / I = 4Pl / \pi d^3 = 5 \text{ 400 pounds per square inch}$$

From Art. 92, the shearing unit-stress on the surface is,

$$S_s = 321 \text{ 000} H / \pi d^3 = 4 \text{ 000 pounds per square inch}$$

The maximum tensile unit-stress on the lower surface at the middle of the shaft or on its upper surface in the bearings now is

$$S_n = 2 \text{ 700} + \sqrt{4000^2 + 2700^2} = 7 \text{ 600 pounds per square inch}$$

and the maximum compressive unit-stress on the upper side of the shaft has the same value; this is 41 percent greater than that due to pure flexure. The maximum shearing unit-stress is

4 900 pounds per square inch, which is 22 percent greater than that due to pure torsion.

It is thus seen that the actual maximum unit-stresses in a shaft due to combined flexure and torsion are much higher than those derived from the formulas for flexure or torsion alone. In determining the diameter d of a shaft, it is hence necessary to take S_n as the allowable tensile or compressive stress and S_p as the allowable shearing unit-stress. For a round shaft of diameter d , the expression for S under any transverse load is $Mc/I = 32M/\pi d^3$ (Arts. 41, 42, 43), while that for S_s is $P\phi \cdot c/J = 16P\phi/\pi d^3$ (Arts. 90, 92). Inserting these in formula (105) and solving for d^3 , there is found

$$\pi S_n d^3 = 16(M + \sqrt{(P\phi)^2 + M^2}) \quad \pi S_p d^3 = 16\sqrt{(P\phi)^2 + M^2} \quad (106)$$

in which M is the bending moment of the loads and $P\phi$ is the twisting moment due to the applied twisting forces. When H horse-powers are transmitted at a speed of n revolutions per minute, the value of $P\phi$ is given by (91). These formulas apply only to solid round shafts; the first is to be used when the normal unit-stress S_n is specified and the second when the shearing unit-stress S_p is specified.

As an example let it be required to find the diameter of a horizontal steel shaft to transmit 90 horse-power at 250 revolutions per minute, when the distance between bearings is 8 feet and there is a load of 480 pounds at the middle, the allowable unit-stresses S_n for flexure being 7 000 and that for shear being 5 000 pounds per square inch. Here the bending moment $M = \frac{1}{8} \times 480 \times 96 = 5\,760$ pound-inches, and the twisting moment $P\phi = 63\,030 \times 90/250 = 22\,690$ pound-inches. Then using the first-formula, the diameter d is found to be 2.8 inches, while from the second formula it is 2.9 inches; hence the shaft should be about 3 inches in diameter.

Formula (106) may also be used for the computation of the maximum working unit-stresses S_n and S_p when the shaft is round and hollow. For a hollow shaft which has the outer diameter d_1 and the inner diameter d_2 , the formula will also apply if $(d_1^4 - d_2^4)/d_1$ be substituted for d^3 .

Prob. 106*a*. Find the factor of safety for the data of Prob. 92*a*, when the shaft is in bearings 12 feet apart and carries a load of 200 pounds at the middle.

Prob. 106*b*. A horizontal nickel-steel shaft of 17 inches outside and 11 inches inside diameter is to transmit 16 000 horse-powers at 50 revolutions per minute, the distance between bearings being 18 feet. Taking into account the flexure due to the weight of the shaft, compute the maximum unit-stresses.

ART. 107. COMPRESSION AND TORSION

When a loaded vertical shaft rests in a step at its foot, the torsional unit-stress S_s combines with the direct compressive unit stress S due to the weight of the shaft and its loads, and there is produced a resultant compression S_n and a resultant shear S_p . These may be computed from (105) after S and S_s have been found. When W is the load on the section area a , the value of S is W/a if the shaft is short, while for long shafts it is to be found from the column formula (80). In order to prevent vibration and flexure it is usual to place bearings at frequent intervals on a vertical shaft so that probably the use of the column formula will rarely be required, particularly when high factors of safety are used. The value of S_s is found from the torsion formula (90), and for a solid round shaft $S_s = 16P\phi/\pi d^3$, where $P\phi$ is the twisting moment which may be replaced in terms of the transmitted power by formula (92).

To find the diameter of a vertical solid round shaft for a given unit-stress S_n or S_p , a tentative method must generally be employed. Inserting $4W/\pi d^2$ for S and $16P\phi/\pi d^3$ for S_s in formulas (105), they become,

$$\pi S_n d^3 = 2Wd + \sqrt{(16P\phi)^2 + (2Wd)^2} \quad \pi S_p d^3 = \sqrt{(16P\phi)^2 + (2Wd)^2}$$

and assumed values of d may be substituted in each of these, until finally a value is found which satisfies the equation. When d is given, however, the unit-stresses S_n and S_p may be directly computed.

A vertical shaft is sometimes so arranged that its weight and that of its loads is supported near the top on a series of circular

disks, sometimes called a thrust-bearing. The shaft is thus brought into tension instead of compression and this is a better arrangement because there is then no liability to lateral flexure. The above method and formulas apply also to this case.

Prob. 107*a*. A vertical shaft, weighing with its loads 6 000 pounds, is subjected to a twisting moment by a force of 300 pounds acting at a distance of 4 feet from its center. If the shaft is wrought iron, 4 feet long and 2 inches in diameter, find its factor of safety.

Prob. 107*b*. Find the diameter of a short vertical steel shaft to carry loads amounting to 6 000 pounds, when twisted by a force of 300 pounds acting at a distance of 4 feet from the center, taking the working unit-stress for compression as 10 000 and that for shearing as 7 000 pounds per square inch.

ART. 108. HORIZONTAL SHEAR IN BEAMS

The common theory of flexure, as presented in Chapter V, considers that the internal stresses at any section are resolved into their horizontal and vertical components, the former producing longitudinal tension and compression and the latter a transverse shear, and that these act independently of each other. The shear formula $S_s a = V$ supposes further that the vertical shear is uniformly distributed over the cross-section of the beam. A closer analysis will show that a horizontal shear exists also and that this, together with the vertical shear, varies in intensity from the neutral surface to the upper and lower sides of the beam. It is well known that a pile of boards which acts like a beam deflects more than a solid timber of the same depth, and this is due to the lack of horizontal resistance between the layers. The common theory of flexure in neglecting the horizontal shear generally errs on the side of safety. In some experiments, however, beams have been known to crack along the neutral surface, and it is hence desirable to investigate the effect of horizontal shear in tending to cause rupture of that kind. That a horizontal shear exists simultaneously with the vertical shear is evident from the considerations in Art. 105.

Let Fig. 108 represent a portion of a beam of uniform section. Let a notch $nm pq$ be imagined to be cut into it, and let forces

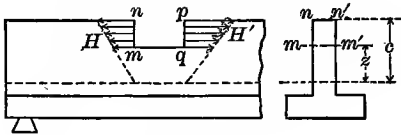

Fig. 108

be applied to it to preserve the equilibrium. Let H be the sum of all the horizontal components of these forces acting on mn and H' the sum of those acting on qp .

Now H' is greater or less than H , hence the difference $H' - H$ must act along mq as a horizontal shear. Let the distance mq be δx , the thickness mm' be t , and the area $mq q' m'$ be at a distance z above the neutral surface. Let c be the distance from that neutral surface to the remotest fiber where the unit-stress is S . Let δa be the section area of any fiber. Let M be the bending moment at the section mn and M' that at qp . Then,

$$S/c = \text{unit-stress at distance unity from neutral surface}$$

$$S \cdot z/c = \text{unit-stress at distance } z \text{ from neutral surface}$$

$$\delta a \cdot S \cdot z/c = \text{stress on fiber } \delta a \text{ at distance } z \text{ from neutral surface}$$

$$(S/c) \int_z^c \delta a = \text{sum of horizontal stresses between } mm' \text{ and } n'n'$$

Now from the flexure formula (41), $S/c = M/I$ for the section mn and also $S/c = M'/I$ for the section pq , where M and M' are the bending moments, and I is the moment of inertia of the entire cross-section. Accordingly,

$$H = \frac{M}{I} \int_z^c \delta a \cdot z \quad H' = \frac{M'}{I} \int_z^c \delta a \cdot z$$

and hence the horizontal shear along mq is expressed by,

$$H' - H = (M' - M) \int_z^c \delta a \cdot z / I$$

Now, the distance mq being δx , the difference $M' - M$ is δM . Also if S_h is the horizontal shearing unit-stress on the area $t \cdot \delta x$, the value of $H' - H$ is $S_h t \delta x$. Again from Art. 47 it is known that $\delta M / \delta x$ is the vertical shear V . Therefore,

$$S_h = (V/I t) \int_z^c \delta a \cdot z \tag{108}$$

is a general formula for the horizontal shearing unit-stress at the distance z from the neutral surface in any section of a beam where the vertical shear is V .

This expression shows that the horizontal shearing unit-stress is greatest at the supports, and zero at the dangerous section where V is zero. The summation expression $\Sigma_0^c \delta a \cdot z$ is the statical moment of the area $mm'nn'$ with reference to the neutral axis; it is zero when $z=c$, and a maximum when $z=0$. Hence the longitudinal unit-shear is zero at the upper and lower sides of the beam and is a maximum at the neutral surface. Formula (108) applies to any form of section, t being its width at the distance z from the neutral axis, and I the moment of inertia of the whole section with respect to that axis. Since the vertical shearing unit-stress at any point is equal to S_h , its value at the neutral surface is,

$$S_s = \frac{V}{It} \Sigma_0^c \delta a \cdot z \quad \text{or} \quad S_s = \frac{V}{It} a_1 c_1$$

in which t is the width of the section at the neutral axis, a_1 is the area of the part of the section on one side of the neutral axis, and c_1 is the distance of the center of gravity of that area, from that axis. This formula gives the maximum shearing unit-stress and it is always greater than the mean which heretofore has been found by dividing V by the section area a .

For a rectangular beam of breadth b and depth d , the value of t is b , and that of I is $\frac{1}{12}bd^3$, while the statical moment $a_1 c_1$ is $\frac{1}{2}bd \cdot \frac{1}{4}d$. By inserting these in the formula, there results $S_s = \frac{3}{2}V/bd = \frac{3}{2} \cdot V/a$. Hence the shearing unit-stress along the neutral surface is 50 percent greater than the mean shear V/a .

Replacing I in the above formula by ar^2 , where r is the radius of gyration of the section area with respect to the neutral axis, it becomes,

$$S_s = \frac{a_1 c_1}{r^2 t} \cdot \frac{V}{a} \quad \text{or} \quad S_s = \sigma \frac{V}{a} \quad (108)'$$

where σ is the number $a_1 c_1 / tr^2$, by which the mean shear V/a is to be multiplied in order to obtain the maximum S_c which acts both horizontally and vertically at the neutral surface. For a circular section of diameter d , the value of t is d , that of r^2 is $\frac{1}{16}d^2$, that of a_1 is $\frac{1}{8}\pi d^2$, and that of c_1 is $2d/3\pi$; accordingly $\sigma = \frac{4}{3}$, and the maximum shearing unit-stress is $S_s = \frac{4}{3} \cdot V/a$, which is $33\frac{1}{3}$ percent greater than the mean.

For an I section the coefficient σ will depend upon the ratio of the flange and web thicknesses to their lengths. As a numerical example, take a steel beam 20 inches deep and weighing 80 pounds per linear foot; the width of flanges being 7.00 inches, the mean thickness of flanges 0.92 inches, and the thickness of web 0.60 inches. Table 6 gives $r=7.86$ inches and $t=0.60$ inches; the statical moment a_1c_1 is to be found by taking the sum of the moments of flange and web areas on one side of the neutral axis with respect to that axis. The flange area is $7.00 \times 0.92 = 6.44$ square inches and its center of gravity is $10.00 - 0.46 = 9.54$ inches from the axis; the web area on one side of the neutral axis is $0.60(10.00 - 0.92) = 5.45$ square inches, and its center of gravity is $\frac{1}{2}(10.00 - 0.92) = 4.54$ inches from the axis. Hence the statical moment a_1c_1 is $6.44 \times 9.54 + 5.45 \times 4.54 = 86.18$ inches³. The coefficient σ now is $86.18/7.86^2 \times 0.6 = 2.32$, so that the shearing unit-stress at the neutral surface is $S_s = 2.32V/a$ or 132 percent greater than the mean unit-shear V/a . It is hence seen that the shearing unit-stress at the neutral surface of a steel I beam or plate girder should not be computed by the common formula when a precise result is required.

Prob. 108. In the Journal of the Franklin Institute for February, 1883, is described an experiment on a spruce joist $3\frac{1}{8} \times 12$ inches and 14 feet long, which broke by tension at the middle and afterwards by shearing along the neutral axis at the end, when loaded at the middle with 12 545 pounds. Find the maximum horizontal shearing unit-stress by the use of the above formula.

ART. 109. LINES OF STRESS IN BEAMS

From the last article it is clear that at any point in a beam there exists a horizontal and vertical shearing unit-stress S_s , the value of which is given by (108). At that point there is also a longitudinal tensile or compressive unit-stress S which may be computed from the flexure formula (41) with the aid of the principle that these stresses vary directly as their distances from the neutral surface. In Art. 105 it was shown that these unit-stresses combine to produce maximum and minimum normal

stresses on planes at right angles to each other and maximum shearing stresses on planes bisecting these. The direction of the shearing stresses and their values are given by

$$\tan 2\phi = \frac{1}{2}S/S_s \quad S_p = (S_s^2 + (\frac{1}{2}S)^2)^{\frac{1}{2}}$$

and from these formulas the lines of maximum shear may be traced throughout the beam.

Art. 108 shows that S_s is greatest at the neutral surface and zero at the upper and lower sides of the beam. The longitudinal tensile or compressive stress S is zero at the neutral surface and greatest at the upper and lower side. Hence ϕ is 0 for the neutral surface, it increases with the distance z from that surface, and it becomes 45° at the upper and lower sides of the beam. The broken lines in Fig. 109 show these lines of shear.

The angle θ which the direction of a maximum or minimum normal stress makes with the neutral surface is greater or less by a right angle than the angle ϕ given by $\cot 2\phi = -\frac{1}{2}S/S_s$, because ϕ is the angle between the neutral surface and the plane against which S_n acts. Accordingly the direction in which the maximum tensile stress acts and its value are given by,

$$\cot 2\theta = \frac{1}{2}S/S_s \quad S_n = \frac{1}{2}S + (S_s^2 + (\frac{1}{2}S)^2)^{\frac{1}{2}}$$

Now S is the greatest at the convex surface of the beam where S_s is 0, and hence $\theta = 0^\circ$. As the neutral surface is approached S decreases and S_s increases, whence θ also increases. At the neutral surface S is 0 and S_s has its greatest value; hence for that surface θ is 45° . The same conclusions follow for the maximum compressive stress on the other side of the neutral surface.

The following figure is an attempt to represent the lines which indicate the directions of the maximum unit-stresses in a beam. The full lines above the neutral surface are those of maximum compression, while those below are lines of maximum tension. The broken lines are those of maximum shear. On any line the intensity of stress varies with the inclination, being greatest where the line is horizontal and least where its inclination is 45° . The lines of maximum shear cut those of maximum tension and compression at angles of 45° . The lines of maximum tension above

the neutral surface and those of maximum compression below it are also shown; they are seen to cut the others at right angles and become vertical at the upper and lower edges of the beam. There is also another set of shear curves which cut at right angles those shown in the figure.

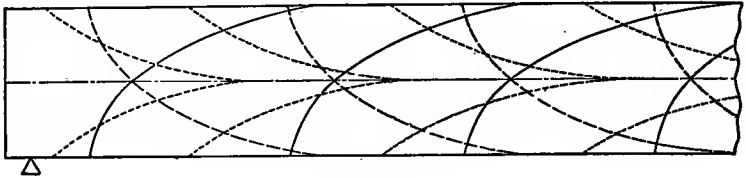

Fig. 109

It appears from this investigation that the common theory of flexure gives the horizontal unit-stress correctly at the dangerous section of a simple beam under uniform load, since there the vertical shear is zero. At other sections the stress S as computed from the flexure formula is correct for the remotest fiber, but for other fibers there are greater normal unit-stresses than the common theory gives. For a heavy concentrated load, where the vertical shear suddenly changes sign at the dangerous section, the common theory gives the horizontal stress S correctly for the remotest fiber only, and it may be possible in some forms of cross-sections that this is slightly less than the maximum S_n at a point nearer to the neutral surface. This, however, is a possibility of rare occurrence, and all that has here been deduced justifies the validity of the common theory of flexure as a correct guide in the practical investigation and design of beams.

The resultant combined stresses found in this chapter are called maximum 'apparent' stresses, since they are the stresses which are apparently correct according to the principles of statics. It will be seen later in Chapter XV that the stresses as measured by the deformations which occur must be considered, these being called 'true stresses'.

Prob. 109a. A joist fixed at both ends is 3×12 inches and 12 feet long, and is stressed by a load at the middle, so that the value of S as computed from (41) is 4 000 pounds per square inch. Find the

values of S_n for points over the support distant 3, 4, and 5 inches from the neutral surface.

Prob. 109*b*. Show, for a point between the neutral surface and the convex side, that there exists a maximum compression as well as a maximum tension. Deduce an expression for the value of this maximum compression and its direction. Draw a figure showing the curves of maximum compression on both sides of the neutral surface of a cantilever beam.

Prob. 109*c*. Consult Weyrauch's *Theorie der Träger* (Leipzig, 1880), and examine his figures showing the lines of stress in a beam with overhanging end. Draw similar figures for a beam fixed at one end and supported at the other.

Prob. 109*d*. Consult Winkler's *Elasticität und Festigkeit* (Prag, 1867), and examine his formulas for deflection and stress of a beam under eccentric and axial tension. Show that these formulas may be much simplified by introducing hyperbolic functions.

CHAPTER XII

COMPOUND COLUMNS AND BEAMS

ART. 110. BARS OF DIFFERENT MATERIALS

Heretofore when a bar or beam has been mentioned, it has been understood that it was of the same material throughout. It is, however, possible to have a bar in which different materials are combined, and beams of this kind are now common in concrete-steel construction. Timber and steel are also sometimes combined in one beam, especially for the floor stringers of electric railway bridges.

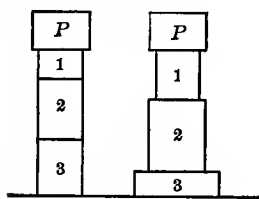

Fig. 110a

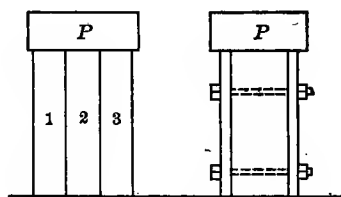

Fig. 110b

In the case of a bar the different materials might occupy different parts of the length as shown in Fig. 110a, where the spaces 1, 2, 3 designate different materials, although this is a method rarely used. In Fig. 110b the three materials are shown arranged longitudinally, this being the method most commonly employed for compound bars. Round bars for jail windows are sometimes made of two kinds of steel, an inner core of soft steel and an outer annulus of very hard steel, the function of the former being to resist lateral bending and that of the latter to resist attempts of the prisoners to file or cut. A compound bar may also be formed of timber and plates of metal bolted together, this being a method more commonly used for beams than for bars. In these figures the bars are represented as short columns under compression, but the following reasoning is general and applies also when compound bars are under tension.

The load P on the bar is supposed to be axial, so that the stress is uniformly distributed over the section area of each material. Considering first the case of Fig. 110*a*, where the materials are arranged in series, it is plain that the total stress in each section area is equal to P . Let l_1, l_2, l_3 be the lengths of the three parts, a_1, a_2, a_3 their section areas, and E_1, E_2, E_3 the moduluses of elasticity of the three materials. The change of length e_1 of the first part is Pl_1/a_1E_1 , that of the second part is $e_2 = Pl_2/a_2E_2$, and that of the third part is Pl_3/a_3E_3 (Art. 10). Accordingly,

$$e = P \left(\frac{l_1}{E_1 a_1} + \frac{l_2}{E_2 a_2} + \frac{l_3}{E_3 a_3} \right) \tag{110}$$

is the total change in length of the bar provided the elastic limit of the material be not exceeded. The unit-stresses in the three parts of the bar are $P/a_1, P/a_2, P/a_3$; when the three section areas are equal, as in the first diagram of Fig. 110*a*, the unit-stresses in the three parts are equal.

For the case of Fig. 110*b*, the three lengths are equal to l , and the three section areas are a_1, a_2, a_3 . Let P_1, P_2, P_3 denote the loads borne by the parts, 1, 2, 3, the sum of these being equal to P . These loads may be found from the fact that the changes of length of the three parts must be equal. Accordingly,

$$P_1 + P_2 + P_3 = P \qquad P_1 l / a_1 E_1 = P_2 l / a_2 E_2 \qquad P_3 l / a_3 E_3 = P_2 l / a_2 E_2$$

are three necessary conditions, and their solution gives,

$$P_1 = P \cdot a_1 E_1 / D \qquad P_2 = P \cdot a_2 E_2 / D \qquad P_3 = P \cdot a_3 E_3 / D \tag{110}'$$

in which D represents the quantity $a_1 E_1 + a_2 E_2 + a_3 E_3$. After P_1, P_2, P_3 have been computed from these formulas, the unit-stresses in the three parts of the bar are found from $S_1 = P_1/a_1, S_2 = P_2/a_2, S_3 = P_3/a_3$. These conclusions are not valid unless each of these unit-stresses is less than the elastic limit of the material, because the formulas for change of length apply only under this condition. By substituting either of the values of P in the corresponding expression for change of length, there is found,

$$e = Pl / (a_1 E_1 + a_2 E_2 + a_3 E_3) \tag{110}''$$

which differs materially from (110). These two formulas have

a marked analogy with the electric equations which connect loss of voltage with current in wires laid in series and in parallel, and this analogy will be discussed in Art. 185.

As a numerical example illustrating the case of Fig. 110*a*, let the three materials be timber, stone, and steel, so that $E_1 = 1\,500\,000$, $E_2 = 6\,000\,000$, $E_3 = 30\,000\,000$ pounds per square inch. Let each section area be a and each length be $\frac{1}{3}l$. Then the unit-stress in every section area is P/a , and formula (110) gives the total change of length as $e = 0.000\,000\,289Pl/a$.

For the case of Fig. 110*b*, let the three materials be also timber, stone, and steel; let each length be l and each section area be $\frac{1}{3}a$. Then formulas (110)' give $P_1 = 0.04P$, $P_2 = 0.16P$, and $P_3 = 0.80P$, so that the stiffest material carries the greatest load, and the unit-stress in the steel is twenty times that in the timber. From (110)'' the change of length is $e = 0.000\,000\,080Pl/a$, or less than one-third of that of the previous case. These less two columns contain the same amount of each material, but the total change of length is the greatest for the first case, while the unit-stress in the steel is the greatest for the second case.

As a numerical example illustrating the second diagram of Fig. 110*b*, let the central part be of timber, 6×8 inches in section, and let two steel plates, each $\frac{3}{8}$ inches thick and 8 inches wide, be bolted to the 8-inch sides. Let the length of the short column be 5 feet, and the axial load P be 126 000 pounds. Here $l = 60$ inches, $a_1 = a_3 = 3$ square inches, $a_2 = 48$ square inches, $E_1 = E_3 = 30\,000\,000$ and $E_2 = 1\,500\,000$ pounds per square inch. Then the formulas give $P_1 = P_3 = \frac{5}{14}P = 45\,000$ pounds, and $P_2 = \frac{7}{4}P = 36\,000$ pounds. The compressive unit-stress in the steel plates then is $S_1 = 45\,000/3 = 15\,000$, and that in the timber is $S_2 = 36\,000/48 = 750$ pounds per square inch. In this case the two steel plates carry about 70 percent of the total load, and are so highly stressed that bolts should be placed at frequent intervals in order to prevent lateral buckling.

Steel ropes are often made with a hemp core in order to give flexibility, and here also the tensile load is divided between the two materials inversely as their resistances. Thus, if a_1 and a_2

are the section areas of the hemp and steel, and E_1 and E_2 their moduluses of elasticity, then $P_1/P_2 = a_1E_1/a_2E_2$, which shows that the steel takes nearly all the load, since a_2 is usually equal to $6a_1$, while E_2 is probably more than 100 times as great as E_1 .

Prob. 110. A bar for a jail window has a diameter of $2\frac{1}{2}$ inches, the central core of soft steel being $1\frac{1}{2}$ inches in diameter. When this bar is used under axial tension or compression, show that the unit-stress on the hard and soft steel is the same.

ART. 111. REINFORCED CONCRETE COLUMNS

A common instance of a compound column is that shown in section in Fig. 111*a*, which represents a hollow cylinder of cast iron or steel filled with concrete and used for one of the supports of a bridge. The usual intention is that the concrete shall carry the load, while the metallic cylinder is to prevent the concrete from cracking under the action of the weather or of collisions from floating objects. Owing to the friction between the two materials, however, it is evident that the metal always carries part of the weight, and the highest load that can come upon it is readily found from the method of Art. 110. Let P be the total load on the pier or column, a_1 and a_2 the section areas of the concrete and metal, and E_1 and E_2 the moduluses of elasticity of the same; then (110)' reduce to,

$$P_1 = P / \left(1 + \frac{a_2 E_2}{a_1 E_1} \right) \quad P_2 = P / \left(1 + \frac{a_1 E_1}{a_2 E_2} \right) \quad (111)$$

are the loads which come on concrete and metal respectively. For example, take a pier where the concrete is 6 feet in diameter, this being surrounded by a cast-iron casing 1.15 inches thick. Using the average values in Table 2, the ratio E_2/E_1 is 5; from Table 16 the area a_1 is 4071 square inches, while the area a_2 is with sufficient precision $\pi \times 73 \times 1.15 = 283$ square inches, and hence the ratio a_1/a_2 is 14.4. Then the formulas give $P_1 = 0.74P$ and $P_2 = 0.26P$, so that the cast iron may carry about one-fourth of the load.

The unit-stresses in the different materials of a compound

column are proportional to their moduluses of elasticity, that is, to the stiffnesses of the materials. This is readily seen from (110)', or, for the case of two materials,

$$P_1 l / a_1 E_1 = P_2 l / a_2 E_2 \quad \text{or} \quad S_2 / S_1 = E_2 / E_1$$

For example, referring to the column of the last paragraph, the value of E_2/E_1 is 5, and hence the unit-stress S_2 in the cast-iron is 5 times the unit-stress S_1 in the concrete.

When bars or rods of metal are placed in a concrete column it is said to be 'reinforced'. Square or rectangular columns are built with vertical steel rods located near the corners, as seen in Fig. 111*b*. In construction the rods are first put in position, they being connected by heavy horizontal wires in order to keep them in place while the concrete is packed in a wooden form which is built around them. Some of the columns of the Harvard stadium are 14 inches square and have vertical steel rods $\frac{3}{8}$ inches in diameter near the corners. Here the section area of the four steel rods is $a_2 = 0.442$ square inches, while that of the concrete is $a_1 = 196 - 0.44 = 195.56$ square inches, so that the ratio $a_1/a_2 = 442$. The average value of the ratio E_2/E_1 is about 10. Accordingly, the formulas give for the load on the concrete $P_1 = 0.978P$ and for the load on the steel $P_2 = 0.022P$. The allowable unit-stress for the concrete was taken as 350 pounds per square inch, hence it follows from the last paragraph that the unit-stress in the steel rods is about 3 500 pounds per square inch. Here the full strength of the metal is not developed, and this is usually the case in reinforced concrete construction.

In the above discussion the column is regarded as so short that no account need be taken of the lateral flexure, and this may be safely done until the height of the column exceeds about twelve times its least diameter. Thus a column 14 inches square may be as high as 14 feet before it is necessary to use any of the formulas given for columns in Chapter IX; the slenderness-ratio l/r corresponding to this rule is about 40 for a square column and 48 for a round column. For higher values of l/r , the method of investigation for the concrete part is to find the load P_1 as above, and then compute the unit-stress S_1 from the column

formula (80), using for the factor ϕ a high number, say about $\frac{1}{1000}$, because sufficient experiments have not been made to determine its proper value. As for the steel, it is everywhere supported by the concrete and can have no lateral flexure except that due to the concrete part, but it will be fair to consider that its unit-stress S_2 is increased in the same proportion as S_1 , due regard being paid to its distance from the axis of the column. For instance, let S_1 and S_2 as computed for a short prism be 300 and 3 000 pounds per square inch, let S_1 on the concave side of the column be found by Rankine's formula to be 500; then S_2 will be 5 000 if the steel is located close to the concave side, but if it be half-way between that side and the axis S_2 will be only $3\ 000 + \frac{1}{2} \times 10 \times 200 = 4\ 000$ pounds per square inch. In general, the unit-stress in the concrete reaches its allowable limit before the steel receives a stress of one-half that which is permissible.

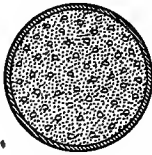

Fig. 111a

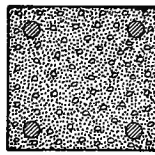

Fig. 111b

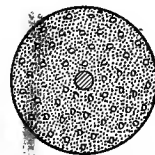

Fig. 111c

A concrete post is often made having a steel rod running longitudinally through it at the axis as in Fig. 111c, this being for the purpose of resisting lateral flexure rather than to assist in carrying loads. Concrete piles are made on the same plan as the bridge column above described, the concrete being enclosed in a metal cylinder. The tunnel under the Hudson river, under construction by the Pennsylvania Railroad in 1906, is supported on steel screw piles filled with concrete. Foundation walls of concrete sometimes have vertical steel rods which help to carry a part of the weight and at the same time prevent the concrete from cracking. Reinforced concrete beams are discussed in Arts. 113-116. Concrete pipes, sewers, arches for buildings and for bridges, are built in which the steel reinforcement plays a more important part than it does in columns. Nearly all of this

reinforced concrete steel construction has been developed since the first edition of this book was published.

Prob. 111. A concrete pile, as designed for the foundation of a building in New York, was 12×12 inches in section area, and had four vertical steel rods, each $1\frac{7}{8}$ inches in diameter and placed at about two inches from the corner. Compute the unit-stresses in concrete and steel at a depth of 12 feet below the top, due to their own weight and to a load of 30 000 pounds on the top.

ART. 112. FLITCHED BEAMS

A 'flitched beam' is one made of timber with metal plates upon its sides, these being held in place by bolts passing through the timber; sometimes, however, a single plate is placed between two timber beams. The following figures show sections of such beams; the third one, which is formed by two channels and a piece of timber, is often used on highway bridges for stringers which support tracks of an electric railway, the rail being fastened to the timber part by spikes or lag bolts. The other forms are sometimes employed in wooden floors. The bolts should in all cases pass through the neutral axis of the section, in order to weaken the beam as little as possible.

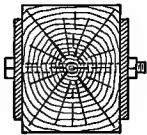

Fig. 112a

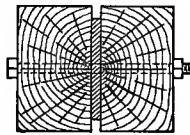

Fig. 112b

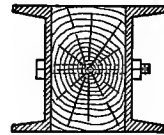

Fig. 112c

When a load is placed upon such a beam it divides itself between the two materials in proportions depending upon their stiffness and section areas. Whether the load be concentrated or uniform it may be expressed by W , and this will divide into two parts, W_1 being that carried by the timber and W_2 that carried by the metal. Since the two materials are fastened together the deflection of each is the same. These conditions enable the values of W_1 and W_2 to be determined in a manner similar to that used for the compound column in Art. 110. The length of the metal

and timber will be taken the same, each being equal to the length l of the span of the beam. The modulus of elasticity of the timber will be denoted by E_1 and that of the steel by E_2 ; the moment of inertia of the cross-section of the timber is I_1 and that of the metal is I_2 .

The deflection f of a beam may be expressed, as in Art. 56, by $Wl^3/\beta EI$, where β is a number depending upon the kind of loading and the arrangement of the ends. From the above conditions,

$$W_1 + W_2 = W \quad W_1 l^3 / \beta E_1 I_1 = W_2 l^3 / \beta E_2 I_2$$

and the solution of these equations gives the values,

$$W_1 = W / \left(1 + \frac{E_2 I_2}{E_1 I_1} \right) \quad W_2 = W / \left(1 + \frac{E_1 I_1}{E_2 I_2} \right) \quad (112)$$

which are seen to be the same as (111) except that a_1 and a_2 are replaced by I_1 and I_2 . After the values of W_1 and W_2 have been computed, the unit-stresses in the timber and steel may be investigated by the method of Art. 48.

For example, let a flitched timber beam like Fig. 112*a* be 8×12 inches in section and each of the steel plates be $\frac{1}{2} \times 9$ inches. For the timber $I_1 = \frac{1}{12} \times 8 \times 12^3$ and for the steel $I_2 = \frac{1}{12} \times 1 \times 9^3$, whence the ratio $I_1/I_2 = 512/27$; also the ratio $E_2/E_1 = 20$. Then (112) gives $W_1 = 0.487W$ and $W_2 = 0.513W$, so that the parts of the load carried by timber and steel are closely equal. Let the length of this simple beam be 15 feet and the total uniform load on it be $W = 16\,000$ pounds, so that $W_1 = 7\,800$ and $W_2 = 8\,200$ pounds. From the flexure formula (41) the unit-stress on the upper and lower sides of the timber at the middle of the span is $S_1 = M_1 c_1 / I_1 = W_1 l c_1 / 8 I_1 = 914$ pounds per square inch; also the unit-stress on the upper and lower sides of the steel at the same section is $S_2 = M_2 c_2 / I_2 = W_2 l c_2 / 8 I_2 = 13\,700$ pounds per square inch. These unit-stresses are safe allowable values for the conditions under which such a beam would generally be used.

To design a flitched beam, the size of the timber is first assumed and then the proper thickness and depth of the metal plates are to be computed. Let S_1 and S_2 be the given allowable unit-stresses; from the above their ratio is $S_1/S_2 = W_1 c_1 I_2 / W_2 c_2 I_1$,

and replacing W_1 and W_2 by their values from (112) this reduces to $S_1/S_2 = E_1 c_1/E_2 c_2$. The total bending moment M , for any kind of loading, is equal to the sum of the resisting moments $S_1 \cdot I_1/c_1$ and $S_2 \cdot I_2/c_2$. Accordingly the two equations for design are,

$$c_2/c_1 = E_1 S_2/E_2 S_1 \quad S_1 \cdot I_1/c_1 + S_2 \cdot I_2/c_2 = M \quad (112)'$$

in which c_1 and c_2 are the half-depths of timber and metal, and hence the ratio d_2/d_1 equals c_2/c_1 . For cast iron and timber the ratio E_2/E_1 is 10, while S_2/S_1 may be taken as about 4 for the tensile side of the beam; hence the depth of the metal should be about four-tenths of the depth of the timber. For structural steel and timber the ratio E_2/E_1 is 20, while S_2/S_1 should be about 15; hence the depth of the steel should be three-fourths of the depth of the timber. When d_1 and d_2 are equal, as in Fig. 112c, the ratio S_1/S_2 equals E_1/E_2 , so that the unit-stress on the timber is one-twentieth of that on the steel.

The proper thickness of the metal plates will depend upon the bending moment M . For rectangular sections the moment equation becomes $S_1 b_1 d_1^2 + S_2 b_2 d_2^2 = 6M$. When the depths d_1 and d_2 are given, as also the width b_1 of the timber, the thickness b_2 of the metal is computed from this equation. For example, let $d_1 = 12$ and $d_2 = 9$ inches for timber and steel; then S_2/S_1 must equal 15. Hence let $S_1 = 1\ 000$ and $S_2 = 15\ 000$ pounds per square inch; let $b_1 = 8$ inches, and let it be required to find b_2 when the total load $W = 15\ 000$ pounds and is concentrated at the middle of a span of 16 feet. Here $M = \frac{1}{4} Wl = 720\ 000$ pound-inches, and then the moment formula gives $b_2 = 2\frac{5}{8}$ inches as the total thickness of metal required.

In the case of the trolley stringer of Fig. 112c, the steel channels carry a large part of the total load W , and they are sometimes designed so that they may carry it all. When the depth of the channels and timber are the same, the above theory shows that the ratio S_1/S_2 equals E_1/E_2 , and hence the flexural unit-stress on the channels is twenty times that on the timber. Thus, if S_2 for the structural steel is taken as 12 000 pounds per square inch, S_1 for the timber will be 600 pounds per square inch. For example,

let the length of a stringer be 21 feet, and the total uniform load upon it be 14 000 pounds, this being an equivalent for the total live and dead load. The moment M is then $\frac{1}{8}Wl = 441\ 000$ inch-pounds. Let the timber be 8 inches wide and 10 inches deep; then $I_1/c_1 = 133.3$ inches³. Using $S_1 = 600$ and $S_2 = 12\ 000$, the value of I_2/c_2 for the two channels is found from the moment formula of (112)' to be 30.1 inches³, whence from Table 9 it is seen that the 10-inch channel which weighs 20 pounds per foot is required. Two channels of this kind have $I_2 = 157.4$ inches⁴, while for the timber $I_1 = 666.7$ inches⁴. Accordingly, by the help of (112) it is found that the channels carry about 83 percent of the total load.

If the metal plates shown in Figs. 112*a* and 112*b* do not extend to the ends of the simple beam, but stop a distance κl from the ends, the above method needs modification. By an investigation to be given in Art. 123 it will be shown that formulas (112) apply to this case if I_1 is multiplied by $1 - 8\kappa^3$. Hence the shortening of the plates throws a larger proportion of the load upon the timber and increases the stress in it at the middle of the span. The condition $S_1/S_2 = E_1c_1/E_2c_2$ is also to be modified by multiplying the second member by $1 - 8\kappa^3$, so that the advantageous ratio c_2/c_1 is less than before. This case need not be discussed further, because plates extending over only a part of the length would rarely be used except in order to strengthen a weak beam, and in such an event no precise computations would be needed.

Prob. 112. Let a flitched beam, like Fig. 112*b*, consist of two timbers each 10 inches wide and 14 inches deep, and a steel plate $\frac{3}{4}$ inches thick and 7 inches wide. When the unit-stress in the timber is 900 pounds per square inch, what is the unit-stress in the steel? What percentage does the metal add to the strength of the wooden beam?

ART. 113. REINFORCED CONCRETE BEAMS

Other methods of longitudinal reinforcement than that described in the last article are used for concrete beams. The method of Fig. 113*a* is occasionally used, but here the resistance

of the concrete to flexure is not generally taken into account, its office being to protect the steel beam from corrosion or fire, while the steel beam is considered to carry all the load. When computations are made on a case of this kind, the formulas of the last article directly apply, the ratio E_2/E_1 being taken from 10 to 15; while the ratio S_2/S_1 of the allowable unit-stresses for the compressive side of the beam will generally range from 8 to 12. Since the ultimate tensile strength of concrete is from 300 to 500 pounds per square inch, an average allowable tensile unit-stress is about 40 pounds per square inch, while that for the steel may easily under steady loads be as high as 15 000 pounds per square inch. Supposing the steel to be stressed only to 8 000 pounds per square inch, it is seen that S_1 for the concrete will be higher than its tensile strength, so that the practice of designing the steel beam to carry all the load is justified, the concrete being considered only as a covering which protects the steel in spite of the cracks on the tensile side.



Fig. 113a



Fig. 113b



Fig. 113c

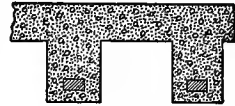

Fig. 113d

In the method of reinforcement seen in Fig. 113b, there are four steel rods arranged symmetrically with respect to the neutral axis; for wide beams a larger number of rods is used, half of them above and half below the neutral axis, the distance of each row from that axis being the same. The formulas of Art. 112 apply directly to this case when c_1 is the half-depth of the rectangular section and c_2 is the distance from the neutral axis to the remotest part of the metal. When the area of metal is small compared to that of the concrete, as is generally the case, it will be sufficiently precise to take the moment of inertia I_2 as equal to the area a of the metal multiplied by the square of the distance h from its center of gravity to the neutral axis, or $I_2 = ah^2$; also it will be sufficiently precise to take $I_1 = \frac{1}{12}bd^3$, thus supposing that the concrete fills also the spaces occupied by the metal.

Considering the uncertainties regarding the values of the ratios E_2/E_1 and S_2/S_1 , this method is entirely satisfactory unless a is more than 10 percent of bd . For example, let the width b be 8 inches, the depth d be 12 inches, and each of the four steel rods be $1\frac{1}{4}$ inches in diameter, the centers of rods being 4 inches from the neutral axis; then $bd=96$ square inches and $a=4.91$ square inches; $c_1=6.0$ and $c_2=4.62$ inches, $I_1=1152$ inches⁴, and $I_2=4.91 \times 4^2=79$ inches⁴. Now, taking $E_2/E_1=10$, the first formula of (112)' gives S_2/S_1 =about 15; accordingly if the safe allowable tensile unit-stress for concrete is taken as 50 pounds per square inch, S_2 for the steel will be only 750 pounds per square inch. The steel and concrete do not work well together, and in fact this design is a poor one. If the load is sufficiently large to make S_2 as high as 12 000 pounds per square inch, a value which the steel may safely bear, the concrete will be ruptured by tension on the convex side, so that it can only serve as a kind of protective covering for the steel rods. The uniform load which these rods can safely carry will then be $W_2=8S_2I_2/c_2l$. For instance, if the simple beam is 8 feet 4 inches long $W_2=16400$ pounds is the load which is carried by the steel if the concrete does not act at all, while $W_1=770$ pounds is the load which might be safely carried by the concrete without any reinforcement. Since this concrete beam weighs about 800 pounds, it would safely carry only its own weight unless reinforced.

Figs. 113c show the methods of reinforcement generally used for concrete beams, the metal being placed only on the tensile side. The theory given in the preceding article is entirely inapplicable to a beam where the metal is only on one side of the neutral axis, and the proper theory will be developed in the two following articles. Various forms of rods are in use, and it has been found that smooth rods are not the best, since there is a tendency for them to slip in the concrete. One of the oldest kinds is a rectangular twisted bar which is known as the Ransome rod; another form is that of Thacher, which is a round bar flattened in two rectangular directions; Johnson's bar is of rectangular section with corrugations alternating on adjacent sides. Another reinforcement is the lozenge-shaped form, called expanded metal,

which is widely used for the beams of floors. The Kahn method consists of rods which are straight near the middle of the beam and bent upward near the ends, the inclined ends being intended to prevent the shearing that sometimes occurs along surfaces which are indicated by the shear lines in Fig. 109.

When steel rods are used in concrete beams, the fundamental idea is that they are for the purpose of increasing the resistance on the tensile side. A plain concrete beam has its neutral surface at the middle and hence the compressive unit-stress on the upper surface is equal to the tensile unit-stress on the lower surface when the elastic limit is not exceeded. Hence in a plain concrete beam the resistance to compression cannot be developed until the beam is ruptured on the tensile side. When rods are placed near the lower side, these take tensile stresses and hence the compressive stresses in the concrete above the neutral surface are increased. In this case the neutral axis no longer passes through the center of gravity of the section, so that new formulas must be established for concrete beams reinforced in this manner, and this will be done in the next article.

Concrete beams are usually rectangular in section, and only these will be discussed in the following pages. The amount of metal which is placed near the tensile side of the section is rarely greater than 2 percent of the total rectangular section area, about 1 percent being the usual practice. Structural steel is mainly employed, although hard steel has been sometimes used. The allowable unit-stress for structural steel is generally taken as 12 000 pounds per square inch, although there would be little objection to stressing it to a value 25 percent higher, but it is difficult to develop the full resistance of the steel, as will be seen later. In the discussions of the following pages the average values of the modulus of elasticity given in Table 2 will be used, and hence the ratio E_2/E_1 will be taken as 10. The allowable working unit-stresses for concrete will be generally taken as 500 pounds per square inch in compression and 60 in tension; these values apply only to first-class concrete of the proportions 1 cement, 2 sand, 4 broken stone (Art. 22).

Prob. 113. A section like Fig. 113*b* is to be used in a floor for a span of $6\frac{1}{2}$ feet, the depth of the beam being 5 inches and its width 4 feet. The steel rods are one inch in diameter and placed so that their centers are $1\frac{1}{2}$ inches from the neutral axis. How many rods are needed in order that they alone may carry a total uniform load of 5 850 pounds with a factor of safety of 5?

ART. 114. THEORY OF REINFORCED CONCRETE BEAMS

The theoretic laws of Art. 39 apply to all kinds of beams, as also the experimental laws 4 and 5 of Art. 40. When different materials are used in a beam law 6 needs modification, for the stiffest material is stressed the highest. Law 5 is to be used in this case, and this states that the unit-elongation or unit-shortening is the same for both materials. Thus at the same distance from the neutral surface S_1/E_1 for the concrete must equal S_2/E_2 for the steel. Law 6 applies, however, to the stresses in each material, and thus the stresses in the concrete vary directly as their distances from the neutral surface. The same is true for the stresses in the metal, but since the section area of this is small, it will usually be sufficient to regard the unit-stresses in the metal as uniformly distributed (Art. 113). Let b be the width and d the depth of the rectangular section, and a the section area of the metal. In strictness the section area of the concrete is $bd - a$, but it will be unnecessary to take the diminution of bd into account, since a is rarely greater than 3 percent of bd .

CASE I. Tension in Concrete. Fig. 114*a* shows a concrete beam reinforced with horizontal steel bars at a distance h below the middle. Let S_1 be the compressive unit-stress mp on the upper side at the dangerous section, S_1' the tensile unit-stress $m'p'$ on the lower side, and S_2 the tensile unit-stress in the steel. Let ss be the neutral surface at the distance k below the middle of the simple beam. The first condition of static equilibrium is that the algebraic sum of all the horizontal stresses in the section shall equal zero; the sum of all the compressive stresses is $\frac{1}{2}S_1b(\frac{1}{2}d + k)$, for the mean unit-stress $\frac{1}{2}S_1$ acts over the area

$b(\frac{1}{2}d+k)$, the sum of all the tensile stresses in the concrete is $\frac{1}{2}S_1'b(\frac{1}{2}d-k)$, the sum of all the tensile stresses in the steel is S_2a . The second condition of static equilibrium is that the sum of the moments of these stresses shall equal the bending moment M ; the moment of the compressive stresses with respect to the neutral axis ss' is $\frac{1}{3}S_1b(\frac{1}{2}d+k)^2$, since the total compressive stress acts with the lever arm $\frac{2}{3}(\frac{1}{2}d+k)$, the moment of the tensile stresses in the concrete is $\frac{1}{3}S_1'b(\frac{1}{2}d-k)^2$, and the moment of the tensile stresses in the steel is $S_2a(h-k)$. Accordingly,

$$\begin{aligned}\frac{1}{2}S_1b(\frac{1}{2}d+k) &= \frac{1}{2}S_1'b(\frac{1}{2}d-k) + S_2a \\ \frac{1}{3}S_1b(\frac{1}{2}d+k)^2 + \frac{1}{3}S_1'b(\frac{1}{2}d-k)^2 + S_2a(h-k) &= M\end{aligned}$$

are two equations connecting the four unknown quantities S_1 , S_1' , S_2 , k . Two other equations result from the law that the unit-elongations are proportional to their distances from the neutral surface: $S_1/S_1' = (\frac{1}{2}d+k)/(\frac{1}{2}d-k)$ applies to the concrete if the elastic limit is not exceeded; S_2/E_2 is the unit-elongation in the steel, and this equals the unit-elongation in the concrete at the distance $h-k$ from the neutral surface, hence $S_2/E_2 = S_1(h-k)/E_1(\frac{1}{2}d-k)$. The solution of the four equations gives,

$$k = \frac{h}{1 + (bd/a)(E_1/E_2)}$$

$$S_1 = \left(1 + \frac{2k}{d}\right)S \quad S_1' = \left(1 - \frac{2k}{d}\right)S \quad S_2 = \frac{E_2}{E_1} \cdot \frac{2(h-k)}{d}S \quad (114)$$

in which S represents the quantity $6M/bd^2$, this being the unit-stress in a plain concrete beam due to the given bending moment M and which is represented by mq and $m'q'$ in Fig. 114a. The position of the neutral surface depends upon h and the ratios bd/a and E_2/E_1 .

The above theory applies only when the unit-stresses do not exceed the elastic limit, but concrete is a brittle material in which the elastic limit is poorly defined, the stress diagram being similar to that of cast iron or brick. However, by using high factors of safety, S_1 and S_1' may be made sufficiently low so that the above formulas have the same validity as the common flexure formula has when applied to brittle materials. Owing to the low tensile strength of concrete, beams often crack on the tensile

side, so that the reinforcing bars carry nearly all of the tensile stresses. It is therefore important to develop the formulas which apply to such a case, and this will now be done under the assumption that all the tensile stress below the neutral surface is carried by the steel bars.

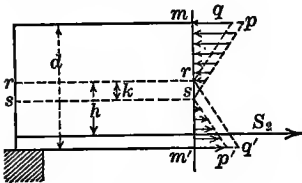

Fig. 114a

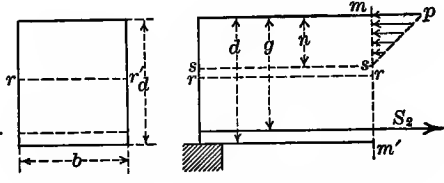

Fig. 114b

CASE II. No Tension in Concrete. Let Fig. 114b represent the case where there are no tensile stresses in the concrete, the notation being the same as before except that the position of the steel is designated by the distance g measured downward from the upper surface of the beam, while the neutral surface ss is at the distance n below the same surface. The compressive unit-stress S_1 on the upper side is represented by mp , while S_2 is the tensile unit-stress in the metal. To determine these quantities, the static laws of Art. 39, together with the experimental laws of Art. 40, are again to be used. The sum of all the horizontal stresses below the neutral axis in the dangerous section is S_2a and the sum of those above it is $\frac{1}{2}S_1bn$, since the average unit-stress $\frac{1}{2}S_1$ acts over the area bn ; hence $S_2a = \frac{1}{2}S_1bn$ is the first equation between S_2 and S_1 . The sum of the moments of all the stresses in the section is the resisting moment which equals the bending moment M . Now $S_2a(g-n)$ is the moment of the stresses in the metal with respect to the axis s , and $\frac{1}{3}S_1bn^2$ is the moment of the stresses in the concrete, since the total stress $\frac{1}{2}S_1bn$ acts with the lever arm $\frac{2}{3}n$; hence $S_2a(g-n) + \frac{1}{3}S_1bn^2$ is the resisting moment which equals M , and this is a second equation between S_2 and S_1 . A third condition is, however, required, since the unknown quantity n is contained in each of those thus far established. This is furnished by the experimental law regarding changes of length; S_2/E_2 is the unit-elongation of the metal which is at the distance $g-n$ from the neutral surface.

while the unit-shortening of the concrete at the same distance from the neutral surface is $S_1(g-n)/E_1n$. Hence,

$$S_2a = \frac{1}{2}S_1bn \quad S_2a(g-n) + \frac{1}{3}S_1bn^2 = M \quad S_2/E_2 = (S_1/E_1)(g-n)/n$$

are three equations for finding n , S_1 , S_2 ; their solution gives

$$n = \frac{a\varepsilon}{b} \left(-1 + \sqrt{1 + \frac{2gb}{\varepsilon a}} \right) \quad S_1 = \frac{M}{\frac{1}{2}bn(g - \frac{1}{3}n)} \quad S_2 = \frac{M}{a(g - \frac{1}{3}n)} \quad (114)'$$

in which ε denotes the ratio E_2/E_1 . These formulas do not contain the depth d , but this is usually 1 or $1\frac{1}{2}$ inches greater than g in order to protect the steel from corrosion.

Prob. 114*a*. A reinforced concrete beam is 5 inches deep, 4 feet wide, $6\frac{1}{2}$ feet in span, has 1.8 square inches of steel at $1\frac{1}{2}$ inches below the middle, and the total load upon it is 6 400 pounds. Show from (114) that the concrete will probably crash on the tensile side.

Prob. 114*b*. Using the above data and supposing that the concrete offers no tensile resistance, compute from (114)' the position of the neutral surface and the unit-stresses S_1 and S_2 .

ART. 115. INVESTIGATION OF REINFORCED CONCRETE BEAMS

The formulas of the last article furnish the means of investigating a reinforced concrete beam for which the dimensions and loads are given. When the beam is lightly loaded, so that the concrete below the neutral surface is in tension, formulas (114) are to be used. When the beam is so heavily loaded that this tensile resistance is overcome, formulas (114)' are to be used, provided the elastic limit of the concrete on the compressive side is not exceeded. This elastic limit is an uncertain quantity, but it is probably not far from 600 or 700 pounds per square inch when the concrete has the proportions of 1 cement, 2 sand, 4 broken stone. When the beam is so heavily loaded that the computed S_1 exceeds this elastic limit, the formulas do not give reliable values of the unit-stresses.

For example, let a reinforced concrete beam be 5 inches deep, 4 feet wide, $4\frac{1}{2}$ feet in span, and have 3.6 square inches of steel placed 2 inches below the middle. Let it be required to investigate

this beam when it carries a uniform load of 2 400 pounds, including its own weight. Here $b=48$, $d=5$, $h=2$ inches; $bd=240$ and $a=3.6$ square inches, whence $a/bd=0.015$; also $E_2/E_1=10$ (Art. 113). Using formulas (114) there is found $k=0.261$ inches for the location of the neutral surface below the middle. The maximum moment is $M=\frac{1}{8}wl=16\ 200$ pound-inches, whence $S=6M/bd^2=81$ pounds per square inch as the flexural unit-stress for a plain concrete beam. Then $S_1=89$, and $S_1'=73$ pounds per square inch for the compressive and tensile stresses on the upper and lower surfaces of the beam, the first giving a factor of safety of about 33, while the second gives a factor of safety of about 4. Also $S_2=560$ pounds per square inch for the steel, which is a very low value, the factor of safety being over 100. While this beam is perfectly safe, it is not designed for proper economy, since the compressive stress in the concrete and the tensile stress in the steel might be much higher.

As another example, let $b=48$, $d=5$, $h=1\frac{1}{2}$, $g=4$, $l=84$ inches, $a=2.4$ square inches, and the total uniform load W be 6 000 pounds. Taking $E_2/E_1=10$, (114) gives $S_1'=400$ pounds per square inch, which is greater than the tensile strength of the concrete, so that these formulas do not apply. Turning then to (114)' there are found $n=1.56$ inches, $S_1=373$ pounds per square inch for the concrete and $S_2=11\ 700$ pounds per square inch for the steel, so that the beam has a proper degree of security.

The formulas of Art. 114 are valid when the unit-stresses in the concrete are proportional to their distances from the neutral surface, and this is the case only when the changes of length are proportional to the stresses. Concrete is a material in which this proportionality exists only for low unit-stresses, so that the validity of the formulas is sometimes questioned. Hatt has deduced formulas under the supposition that the unit-stresses vary with their distances from the axis according to a parabolic law, and these will undoubtedly give a better agreement with experiment than (114)' when the concrete is highly stressed. For a case of design, however, the prevailing opinion is that formulas (116) should be used, and this has been the common

practice since 1900. The general laws involved in formulas (114)^r are confirmed by experiments in which beams are ruptured, although numerical values computed from the formulas are of little reliability except as empirical results similar to that of the computed flexural strength or modulus of rupture for beams of one material (Art. 52).

The phenomena of failure of a reinforced concrete beam have been completely ascertained by the very valuable experiments made by Talbot in 1904. These beams were 12 inches wide, $13\frac{1}{2}$ inches deep, 14 feet in span, and had the steel reinforcing bars 12 inches below the top surface. Various percentages of metal were used, ranging from 0.42 to 1.56 percent of that of the concrete, and several kinds of reinforcing bars were employed. The beams were tested by applying two concentrated loads at the third points of the span, and the deflections at the middle were measured for several increments of loading, as also, horizontal changes of length. Under light loads the tensile resistance of the concrete was plainly apparent; when the tensile unit-stress in the concrete reached about 350 pounds per square inch, the neutral surface rose and the stress in the steel increased. A little later fine vertical cracks appeared on the tensile side, while the tensile stresses in the steel and the compressive stress in the concrete increased faster than the increments of the load. The last stage was a rapid increase of the deformations, and rupture occurred by the crushing of the concrete on the upper surface, the steel being then generally stressed beyond its elastic limit.

In some cases reinforced concrete beams have been known to fail by shearing near the ends, the curve of rupture being like that shown by the broken lines in Fig. 109. The full investigation of this case is attended with some difficulty and will not here be attempted, but the discussion of Art. 108 furnishes the means of making approximate computations. It is only short beams which fail in this manner. When rupture occurs near the middle of the beam along a curved surface which roughly agrees with one of the full lines in Fig. 109, this is not a case of shearing but one of rupture by tension.

The safe load which may be carried by a reinforced concrete beam can be computed in five ways from the formulas of Art. 114. Under Case I the first step is to find k , and then to place its value in the three following equations. Allowable values of S_1 , S_1' , and S_2 being assumed, three computations may be made to find three values of S from which three values of M are determined; then for uniform load $W = 8M/l$ and the smallest of the three values of W is the one to be selected on the theory of Case I, where no cracking of the concrete is allowed. Larger values of W will be found by using the formulas of Case II, the first step being to compute n , the second to find two values of M from assumed values of S_1 and S_2 , and the third to compute two values of W , the smaller of which is the safe load. Computations generally show that a reinforced concrete beam is stronger after it has cracked on the tensile side than it was before, this being due to the fact that the steel then has a higher unit-stress. These cracks may not be visible and they are often called hair cracks; they exist whenever the unit-stress on the tensile side of the beam reaches or exceeds the ultimate strength.

Prob. 115*a*. A reinforced concrete beam is 12 inches wide, 15 inches deep, 14 feet long, and has 3.6 square inches at $1\frac{1}{2}$ inches from the lower side. Find the total uniform load W which this beam can carry so that the tensile stress in the concrete on the lower side may be 100 pounds per square inch.

Prob. 115*b*. Using the same data as above, compute the total uniform load which will produce a compressive stress of 500 pounds per square inch on the concrete, considering that the concrete below the neutral surface offers no tensile resistance.

ART. 116. DESIGN OF REINFORCED CONCRETE BEAMS

When a reinforced concrete beam is to be built, its width, depth, and span are given or assumed, as also the load which is to be carried and the allowable unit-stresses for the concrete and steel. The problem of design then consists in determining the proper section area of the reinforcing bars and the proper depth of the beam. As for the position of these bars, it is apparent that they should be placed as near as possible to the tensile

side of the beam in order that their resisting moment may be as large as possible. They should, however, be entirely covered by the concrete in order to be protected from corrosion due to atmospheric influences.

It is impossible to design an economical reinforced concrete beam on the theory of Case I of Art. 114, for if S' be taken even as high as the ultimate tensile strength of the concrete, the values of S_1 and S_2 are too low; S_2 for the steel is indeed always less than S_1' , so that the strength of the metal is not utilized. Nothing remains to be done, therefore, but to allow the concrete to crack on the tensile side and thus bring proper tension into the steel. If the tensile resistance of the concrete is not considered, formulas (114)' apply. The given quantities are E_2/E_1 or ϵ , the width b , the unit-stresses S_1 and S_1' , and the bending moment M . Eliminating n from the three equations, there are found two equations containing g and a , and the solution of these gives

$$g = \frac{\epsilon + \sigma}{\sqrt{2\epsilon^2 + 3\epsilon\sigma}} \sqrt{\frac{6M}{bS_1}} \quad a = \frac{\epsilon}{2\sigma(\epsilon + \sigma)} bg \quad (116)$$

in which σ denotes the ratio S_2/S_1 . The unit-stress S_1 should be taken as high as allowable; S_2 should not be higher than the allowable value, but it may be taken lower, if economy in cost is thereby promoted. The depth d is made about $1\frac{1}{2}$ inches greater than g .

For example a beam is to be built of concrete which has the proportions 1 cement, 3 sand, 6 stone, for which the ratio $E_2/E_1 = \epsilon = 15$. The span is to be 14 feet, the breadth 20 inches, and the total uniform load is to be 7 000 pounds. It is required to find the depth of the beam and the section area of the reinforcing steel rods so that the unit-stresses S_1 and S_2 shall be 350 and 14 000 pounds per square inch respectively. Here $\sigma = 40$, and $M = \frac{1}{8} \times 7\,000 \times 14 \times 12 = 147\,000$ pound-inches. Inserting the given values in the first of the above formulas, there is found $g = 13.0$ inches, then $bg = 260$ square inches, and from the second formula $a = 0.90$ square inches. Here the section area of the steel is 0.35 percent of the section of the beam above the centers

of the rods. By using a lower value of S_2 , the depth g will be smaller and the section area a will be greater than the above values. The best set of values will be those which render the cost of the beam a minimum.

The position of the neutral surface depends only upon the values of the ratios ϵ and σ . The value of n , as found from the solution of the equations (114)', is

$$n = \frac{g}{1 + \sigma/\epsilon} \quad \text{or} \quad n = \frac{\epsilon}{\epsilon + \sigma} g \quad (116)'$$

For instance, in the case of the last paragraph, where $\epsilon = 15$ and $\sigma = 40$, the value of n is $0.385 g$, so that the neutral surface is 5.0 inches below the upper side of the beam.

Steel is the only material which has been advantageously used for reinforcing rods in concrete beams, and the proper section area should rarely exceed one percent of that part of the concrete above the centers of the rods. With unit-stresses of 5 000 and 500 pounds per square inch for steel and concrete respectively, the section area of the steel is $2\frac{1}{2}$ percent of that of the concrete when the ratio ϵ is 10 and 3 percent when ϵ is 15, but this is an excessive use of steel which is not economical. The following are computed values of a/bg in percentages, and also values of the ratio n/g :

$S_2/S_1 =$	15	20	25	30	35
$a/bg =$	1.33	0.83	0.58	0.42	0.32
$n/g =$	0.40	0.33	0.29	0.25	0.22

These apply to first-class concrete, for which $\epsilon = 10$. As a general rule the most economic dimensions will be obtained by taking S_2 as about 30 times S_1 for concrete made of 1 cement, 2 sand, 3 stone, while S_2 should be taken as about 12 500 and S_1 as about 350 pounds per square inch for concrete of 1 cement, 3 sand, 6 stone, the ratio S_2/S_1 being here 35.

Beams having a section like that of Fig. 113*d* are sometimes used, it being considered that only the upper part of the concrete is stressed in compression, while the tensile stresses in the lower projecting parts are neglected. The design of these is hence made by the formulas (114)', where n is the depth of the upper

slab, g the depth from its upper surface to the center of the steel rods, and b the width of slab belonging to one rod. These formulas may be written

$$g = n \left(1 + \frac{\sigma}{\varepsilon} \right) \qquad a = \frac{1}{2} \frac{bn}{\sigma}$$

from the first of which g is to be found for a given depth n , while the second gives the metal section a . For example, let $E_2/E_1 = \varepsilon = 10$, $S_2/S_1 = \sigma = 25$, $n = 4$ and $b = 18$ inches; then $g = 14.0$ inches and $a = 1.42$ square inches. The safe load which this beam can carry may be found from $M = S_2 a (g - \frac{1}{3}n)$; for instance, in the above case let $S_2 = 12\,500$ pounds per square inch, then the safe bending moment is 22 000 pound-inches.

Prob. 116. Consult a paper by Sewall and the accompanying discussions in Transactions of American Society of Civil Engineers, 1906, Vol. 56. Ascertain different opinions as to what should be the comparative cost of concrete and steel in order to produce the most economical reinforced concrete beam.

ART. 117. PLATE GIRDERS

A plate girder is composed of only one material, usually structural steel, but it may be called compound in the sense that it consists of different parts riveted together. Fig. 117 shows a side view and section of a plate girder without the rivets which connect the web to the angles and the angles to the cover plates. In the section Aa there are four angles and the web; to the right of the section Bb there are in addition two cover plates; to the right of the section Cc there are four cover plates in addition to the angles and web. The section areas and moments of inertia are hence different in the three sections, the plate girder being in fact an approximation to a beam of uniform strength (Art. 58).

The flexure formula (41) may be used to investigate the strength of a plate girder in exactly the same manner as if it were a solid beam. Let I_1 be the moment of inertia of the uniform section between Aa and Bb , I_2 that between Bb and Cc , and I_3 that between Cc and Dd . Then $S = M_1 \cdot c_1/I_1$ applies to the first section, $S = M_2 \cdot c_2/I_2$ to the second section, and

so on. By the help of this formula sections may also be found to resist the bending moments under a specified unit-stress S . For example, let the load be uniform and expressed by w per linear unit; let l be the length of the beam, and the three distances ab , ac , ad , be $0.2l$, $0.35l$, and $0.5l$. Then from Art. 38, the bending moment at Bb is $0.080wl^2$, that at Cc is $0.114wl^2$, and that at Dd is $0.125wl^2$. Hence the value of I_1/c_1 is $0.08wl^2/S$, that of I_2/c_2 is $0.114wl^2/S$, and that of I_3/c_3 is $0.125wl^2/S$. Sections of plates, angles and web may now be determined, with the help of Art. 44 and Table 10, to satisfy these requirements. Then the section Aa must be investigated to ascertain whether it is sufficiently large to safely resist the vertical shear $\frac{1}{2}wl$.

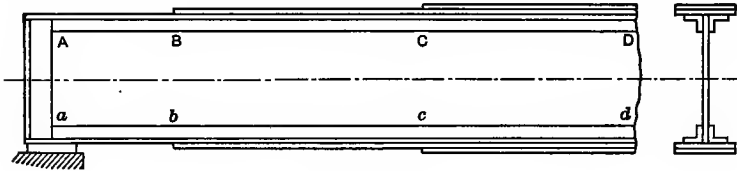

Fig. 117

Another method which is frequently used in practice is to regard the web as carrying none of the bending moment, and to consider that the unit-stresses in the flanges are uniformly distributed so that the total stress in each flange may be regarded as acting at its center of gravity. Let d be the depth between the centers of gravity of the flanges, a the section area of one flange, and S the allowable unit-stress. Then the stress Sa in one flange acts with the lever arm d with respect to the center of gravity of the other flange, and therefore Sad equals the bending moment M . Thus, for the first section $a_1 = M_1/Sd_1$, for the second section $a_2 = M_2/Sd_2$, and so on; from these values of a proper angles and plates may be selected. The section area of the web is determined in this method from the maximum vertical shear which can act at the end. The thickness of the web is made uniform throughout the span; $\frac{3}{8}$, $\frac{1}{2}$ and $\frac{5}{8}$ inches are common thicknesses, as these are standard market sizes. The web is usually stiffened by vertical angles riveted to it at intervals.

After a thickness has been determined for the web from the vertical shear, it cannot generally be altered if the depth of the girder is slightly changed on account of the requirement that market sizes shall be used. There is then a certain depth, called the "economic depth," which gives a smaller amount of material than any other. For the simple case where the flange areas are uniform throughout, there being no cover plates, this economic depth may be determined in the following manner. The section area of each flange is M/Sd , and the section area of the web is td . The total volume of material, neglecting rivets, splices, and stiffeners, then is $(2M/Sd + td)l$. Differentiating this with respect to d , and equating the derivative to zero, gives $d^2 = 2M/St$, which determines the economic depth. This condition shows that $2M/Sd$ equals td , that is, the girder has its economic depth when the amount of material in the flanges is equal to that in the web. This rule holds approximately when cover plates are used, as shown by the investigations in Part III of Roofs and Bridges, where are also given in full detail the methods of designing plate girders for stringers, floor beams, and bridges.

Prob. 117. A plate girder used as a floor stringer has a span of 22 feet, and the uniform load w per linear foot which is equivalent to the actual wheel loads is 1700 pounds. For an effective depth d of 34 inches, compute the flange areas at the middle and the quarter sections, taking S as 12000 pounds per square inch.

ART. 118. DEFLECTION OF COMPOUND BEAMS

The deflection of flitched beams, like those of Art. 112, is readily computed, when the elastic limit of the material is not exceeded, by the use of the formula $f = W_1 l^3 / \alpha E_1 I_1$ in which W_1 is the total load that comes on the material that has the modulus of elasticity E_1 and the moment of inertia I_1 . The same method applies to the compound beams of Fig. 113a and 113b, but it does not apply when reinforcing bars are placed only on one side of the neutral surface of a concrete beam. Con-

crete-steel beams are usually of short span, and it is rarely necessary to compute deflections. Formulas might, indeed, be devised for this case, but they would be of uncertain application on account of the uncertainty in the value of E_1 and because resisting tensile stresses might not exist near the middle of the beam, while they would act near the ends.

For plate girders it is sometimes important to compute the deflection at the end of a cantilever arm or at the middle of a simple span. For a simple span under uniform load the deflection found in Art. 55 is $f = 5wl^4/384EI$, which applies to a plate girder where the moment of inertia I is constant throughout. If I_1 is the moment of inertia of the section near the end and I_3 that of the section at the middle, as in Fig. 117, then for these values there may be found two deflections f_1 and f_2 , the first of which is greater and the second less than the true deflection. It is often the case that this information is all that is required, but by the method of Art. 124 a formula giving a closer result can be deduced. Let l_1, l_2, l_3 be the distances from the left end in Fig. 117 to the sections $Bb, Cc,$ and Dd , so that l_3 is one-half of the span l . Let the load be uniform so that the bending moment at the distance x from the support is $M = \frac{1}{2}wlx - \frac{1}{2}wx^2$. Let m be the bending moment due to a load unity at the middle of the beam or $m = \frac{1}{2}x$. Then, by (124),

$$f = \int \frac{Mm}{EI} \delta x = 2 \int_0^{l_1} \frac{Mm}{EI_1} \delta x + 2 \int_{l_1}^{l_2} \frac{Mm}{EI_2} \delta x + 2 \int_{l_2}^{l_3} \frac{Mm}{EI_3}$$

gives the deflection at the middle under the uniform load. Integrating between the designated limits, there is found,

$$f = \frac{wl}{6E} \left(\frac{l_1^3}{I_1} + \frac{l_2^3 - l_1^3}{I_2} + \frac{l_3^3 - l_2^3}{I_3} \right) - \frac{w}{8E} \left(\frac{l_1^4}{I_1} + \frac{l_2^4 - l_1^4}{I_2} + \frac{l_3^4 - l_2^4}{I_3} \right)$$

This formula is not difficult in computations when tables of squares, cubes, and reciprocals are at hand; thus l_1^3/I_1 is found by taking l_1^3 from the table and multiplying it by the reciprocal of I_1 .

The above gives the elastic deflection due to the horizontal flexural stresses only. Art. 125 shows, however, that there is a deflection due to the vertical shears which must be added to

the above in order to obtain the exact deflection. Let V be the shear due to the given uniform load and v be the shear due to the load unity at the middle of the beam, so that $V = \frac{1}{2}wl - wx$ and $v = \frac{1}{2}$. Then, by (125),

$$f = \int \frac{Vv}{Fa} \delta x = 2 \int_0^{l_1} \frac{Vv}{Fa_1} \delta x + 2 \int_{l_1}^{l_2} \frac{Vv}{Fa_2} \delta x + 2 \int_{l_2}^{l_3} \frac{Vv}{Fa_3} \delta x$$

in which a_1, a_2, a_3 are the section areas whose moments of inertia are I_1, I_2, I_3 , and F is the shearing modulus of elasticity. Performing the integrations, there is found,

$$f = \frac{wl}{2F} \left(\frac{l_1}{a_1} + \frac{l_2 - l_1}{a_2} + \frac{l_3 - l_2}{a_3} \right) - \frac{w}{2F} \left(\frac{l_1^2}{a_1} + \frac{l_2^2 - l_1^2}{a_2} + \frac{l_3^2 - l_2^2}{a_3} \right)$$

which is the deflection at the middle of the beam under the uniform load due to the vertical shears. The numerical value of this shearing deflection is usually small compared to that due to the bending moments, but in short spans it is an appreciable quantity.

Prob. 118. Deduce, from the above formulas, the deflections due to vertical shears and bending moments when the simple beam has the constant section area a and the constant moment of inertia I . Show that the length of beam for which these two deflections are equal is given by $(l/r)^2 = 48E/5F$, where r is the radius of gyration of the section.

CHAPTER XIII

RESILIENCE AND WORK

ART. 119. EXTERNAL WORK AND INTERNAL ENERGY

When a force is applied to a body it overcomes a resistance through a certain distance and thus external work is performed on the body. It is usually the case that the force is applied by increments, so that it increases uniformly and gradually from 0 up to its full value P . When a tensile load is applied in this manner to a bar producing the elongation e , the work performed is $\frac{1}{2}Pe$, or equal to the mean load $\frac{1}{2}P$ multiplied by the distance e . This is otherwise seen from Fig. 14a, where the shaded area represents the work performed while the load increases from 0 to P . Similarly, in the case of a beam under a single load, the load increases from 0 to P and produces the deflection f , so that the work performed is $\frac{1}{2}Pf$. This work done upon the bar or beam is called the 'external work'.

When the elasticity of the body is not impaired and the load is applied so gradually that no work is expended in producing heat, there is stored within the body an amount of energy equal to the external work. This is called 'internal energy', or sometimes 'internal potential energy', because this energy may be utilized to perform an amount of work equal to the external work performed upon it. When the elastic limit of the material is not exceeded, the internal energy in a stressed bar is equal to $\frac{1}{2}Pe$ and that in a beam stressed by a single load is equal to $\frac{1}{2}Pf$. That these statements are correct, many experiments can testify, and they also follow from the law of conservation of energy.

The internal energy which can be stored in a metal bar is very small compared with that which is stored in a mass of steam or compressed air of the same weight. For example, take a bar of structural steel, 6 square inches in section area and 25 feet

long. The load P which will stress this bar to its elastic limit is $P = 6 \times 35\,000 = 210\,000$ pounds, and the elongation under this load is $e = 35\,000 \times 25 / 30\,000\,000 = 0.0292$ feet; hence the work stored in the bar is $K = \frac{1}{2} \times 210\,000 \times 0.0292 = 3060$ foot-pounds. This bar weighs $8\frac{1}{3} \times 6 \times 10 \times 1.02 = 510$ pounds (Art. 17), and an equal weight of air will occupy about 6 320 cubic feet. If this air is in a pipe of one foot diameter, it will fill a length of 8 040 feet, and under a pressure of 15 pounds per square inch above the atmospheric pressure, it may be compressed to half this length. The force P here is 1 700 pounds, and the energy stored in the air is $\frac{1}{2} \times 1\,700 \times 4020 = 3\,517\,000$ foot-pounds, which is nearly 1 200 times as great as that stored in the steel bar. The materials of construction cannot, therefore, be advantageously used for the storage of energy.

If the above steel bar is used as a simple beam with a single load at the middle, the section being square, the load P which will stress it to the elastic limit is found from the flexure formula (41) to be $P = 1\,143$ pounds. The deflection f under this load is found from Art. 55 to be $f = 7.14$ inches. Hence the energy stored in the beam is $\frac{1}{2} \times 1\,143 \times 7.14 / 12 = 340$ foot-pounds, or only one-ninth of that stored in the bar. Springs in the form of beams are used on vehicles to lessen the shocks which occur during motion, but they cannot be used to store energy for the propulsion of a vehicle, on account of the great weight which would be required.

When a bar is already under a load P_1 which has produced the elongation e_1 , an additional load P_2 produces the elongation e_2 , so that the total energy stored in the bar is $\frac{1}{2}(P_1 + P_2)(e_1 + e_2)$, as clearly appears from Fig. 119*b*. When P_2 is removed, the work that can be performed by the stored energy is that represented by the shaded area or $\frac{1}{2}(2P_1 + P_2)e_2$. Or, if the load on a bar ranges from the lower value P_1 to the higher value P , as in Fig. 119*c*, the elongation being e_1 for the former and e for the latter, then the work K performed on the bar, or the energy K stored in it by the increase of P_1 to P , is given by $K = \frac{1}{2}Pe - \frac{1}{2}P_1e_1$. Similarly, when a beam is under a single load which increases

from P_1 to P , while the deflection increases from f_1 to f , the external work and the stored energy due to this increase are both expressed by $K = \frac{1}{2}Pf - \frac{1}{2}P_1f_1$.

When a part of a bar is considered which has a length of unity and a section area of unity, the load P is the unit-stress S and the elongation e is the unit-elongation ϵ . Thus,

$$K = \frac{1}{2}S\epsilon \quad K = \frac{1}{2}S\epsilon - \frac{1}{2}S_1\epsilon_1 \tag{119}$$

are the expressions for the work performed on one cubic unit of the material, the first being for the case where the unit-stress increases from 0 up to S and the second for the case where the unit-stress increases from S_1 up to S .

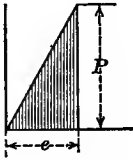

Fig. 119a

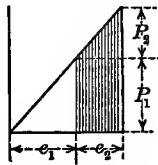

Fig. 119b

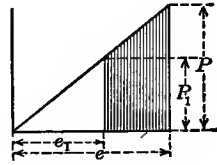

Fig. 119c

When the bar is stressed so that S exceeds the elastic limit of the material, the elongations increase more rapidly than the stresses and the above formulas are inapplicable. Art. 14 shows that the external work required for rupture is very large compared with that required to stress the bar up to its elastic limit, particularly for wrought iron and steel. The area in Fig. 14c between the curve and the axis of elongations measures this external work. For wrought iron and steel the portion of the area below the elastic limit is so small that it may be disregarded, and then the area may be roughly expressed as that of a trapezoid having the length ϵ equal to the ultimate elongation, and limited by the two ordinates which represent the elastic limit and the ultimate strength. Taking the elastic limit as one-half of the ultimate strength, the area of this trapezoid is $K = \frac{3}{4}\epsilon S_u$, which is the work required to rupture by tension one cubic unit of the bar. For example, take the two specimens of unannealed and annealed Bessemer steel in the table of Art. 25, which had $S_u = 125\,000$ and $\epsilon = 0.11$ before annealing and $S_u = 99\,000$ and

$e = 0.19$ after annealing; here $K = 10\ 300$ inch-pounds for the first and $K = 14\ 100$ inch-pounds for the second, so that the process of annealing increased 37 percent the capacity of the steel to withstand external work. Another formula sometimes used for unit rupture work is $K = \frac{1}{2}e(S_e + 2S_u)$, where S_e is the elastic limit and S_u the ultimate strength.

Prob. 119*a*. How many foot-pounds of work are required to stress a wrought-iron bar, 4 inches in diameter and 54 inches long, from 6 000 up to 12 000 pounds per square inch?

Prob. 119*b*. If this bar is used as a beam with a load at the middle, how many foot-pounds of work are required to increase the greatest unit-stress at the dangerous section from 6 000 up to 12 000 pounds per square inch?

ART. 120. RESILIENCE OF BARS

The term "Resilience" is frequently used to designate the work that can be obtained from a body under stress when it is relieved of its load. When the elastic limit of the material is not exceeded this work must be that stored within the bar in the form of stress energy. In Art. 14, as well as in Art. 119, it was shown that the external work performed in elongating or shortening a bar is $\frac{1}{2}Pe$, and this is the resilience which may be utilized when the bar is entirely relieved from stress. Let the section area of the bar be a and the uniform unit-stress be S , then $P = aS$; also let the length of the bar be l and the modulus of elasticity of the material be E , then the change of length is $e = (S/E)l$. Hence, the elastic resilience of the bar is,

$$K = \frac{1}{2}Pe \quad \text{or} \quad K = \frac{1}{2}(S^2/E)al \quad (120)$$

and the factor $\frac{1}{2}S^2/E$ is called the 'modulus of resilience' of the material when S is the unit-stress at the elastic limit.

The following are average values of the modulus of resilience of materials which have been computed from the average constants given in Arts. 4 and 9:

$$\begin{array}{ll} \text{for timber,} & \frac{1}{2}S_e^2/E = 3.0 \text{ inch-pounds per cubic inch} \\ \text{for cast iron,} & \frac{1}{2}S_e^2/E = 1.2 \text{ inch-pounds per cubic inch} \end{array}$$

for wrought iron, $\frac{1}{2}S_e^2/E = 12.5$ inch-pounds per cubic inch
 for structural steel, $\frac{1}{2}S_e^2/E = 20.4$ inch-pounds per cubic inch

Resilience is a measure of the capacity of a body to resist external work, and the higher the modulus of resilience the greater is the capacity of a material both to store up energy and to resist work that may be performed upon it. The modulus of resilience measures this capacity up to the elastic limit only. The total elastic resilience of a bar is found by multiplying the modulus of resilience by the volume of the bar, as (120) shows. Thus, a bar of structural steel, 6 square inches in section area and 25 feet long, has a volume of 1 800 cubic inches, and hence its elastic resilience is 36 720 inch-pounds or 3 060 foot-pounds.

When a bar is stressed by a load which increases from P_1 to P , the unit-stress increases from S_1 to S , and by (120) the resilience of the bar when the load is decreased from P to P_1 is

$$K = \frac{1}{2}(S^2/E)al - \frac{1}{2}(S_1^2/E)al = \frac{1}{2}(S^2 - S_1^2)/E \cdot al$$

Here, as before, the unit-stress S must not be greater than the elastic limit of the material of the bar.

The word resilience implies a spring, and it should not be used except for that part of the applied work which can be recovered when the load is removed. When the elastic limit is exceeded and the load is released, the expression $\frac{1}{2}(S^2/E)al$ also applies, as shown in Art. 14, to the work that can be utilized, but numerical values of this resilience are of no importance when S is the ultimate strength, because the capacity of a material to withstand external work is properly measured by the product of its ultimate strength and ultimate elongation, as explained at the close of Art. 119.

Prob. 120*a*. What horse-power engine is required to stress, 250 times per minute, a bar of wrought iron 18 feet long and 2 inches in diameter from 0 up to its elastic limit?

Prob. 120*b*. What horse-power engine is required to stress, 250 times per minute, a bar of wrought iron 18 feet long and 2 inches in diameter from 12 500 up to 25 000 pounds per square inch?

ART. 121. RESILIENCE OF BEAMS

When a cantilever beam deflects under the action of a load at the end or a simple beam deflects under a load at the middle, the external work is $\frac{1}{2}Wf$ as long as the deflection f increases proportionally to the load which is applied by increments so that it increases gradually from 0 up to the value W (Art. 119). The resilience of the beam then equals $\frac{1}{2}Wf$ and an expression for its value in terms of the flexural unit-stress S may be obtained by substituting for W and f their values from Art. 56. Let l be the length of the beam, c the distance from the neutral surface to the upper or lower side of the beam where the unit-stress is S , and I the moment of inertia of the cross-section; then,

$$W = \alpha SI/c \qquad f = \alpha S l^2 / \beta c E$$

where α is 1 for a cantilever loaded at the end and 4 for a simple beam loaded at the middle, while β is 3 for the cantilever and 48 for the simple beam. Replacing I by ar^2 , where a is the section area and r the radius of gyration of that section with respect to the neutral axis, the elastic resilience of the beam is,

$$K = \frac{1}{2}Wf = (\alpha^2/\beta)(r/c)^2 \frac{1}{2}(S^2/E) \cdot al$$

in which $\frac{1}{2}(S^2/E)$ is the modulus of resilience of the material and al is the volume of the beam.

For either a cantilever or a simple beam the value of α^2/β is $\frac{1}{3}$. For a rectangular section the value of $(r/c)^2$ is $\frac{1}{3}$; hence for a rectangular beam under a single load, the elastic resilience is $K = \frac{1}{3} \cdot \frac{1}{2}(S^2/E)al$, which is one-ninth of that of a bar under tension or compression. For a circular section, the value of $(r/c)^2$ is $\frac{1}{4}$, and it hence follows that its elastic resilience under a single load is one-twelfth of that of a bar under axial stress. For the I sections in Table 6 the value of $(r/c)^2$ is about $\frac{9}{16}$, so that their resilience is greater than that of rectangular or circular sections.

When a beam is uniformly loaded with w per linear unit the load on any short length δx is $w \cdot \delta x$, and if y is the deflection at the point whose abscissa is x , the elementary external work for a gradually applied load is $\frac{1}{2}wy \cdot \delta x$. The integration of

this over the entire length of the beam will give the total external work of the uniform load. For example, take a cantilever loaded uniformly; the value of y is given by the equation of the elastic curve in Art. 54, and accordingly,

$$K = (w^2/48EI) \int_0^l (3l^4 - 4l^3x + x^4) \delta x = w^2 l^5 / 40EI = W^2 l^3 / 40EI$$

is the external work of the uniform load. Substituting for W its value in terms of S , and for l its value av^2 , the resilience of a rectangular cantilever under uniform load is found to be $K = \frac{1}{15} \cdot \frac{1}{2} (S^2/E) al$, which is three-fifths of that found for the concentrated load at the middle.

The above investigation shows that the elastic resilience of a beam is proportional to the product of the modulus of resilience, the volume of the beam, and the ratio $(r/c)^2$. Since, however, this ratio always has a numerical value which is the same for similar sections, it may be stated as a general law, that the resiliences of beams having similar cross-sections are proportional to their volumes.

The strength of a rectangular beam increases with the square of its depth and its stiffness with the cube of the depth (Art. 56). The resilience, however, increases with the section area. Hence it is immaterial whether the short or the long side of the section is placed vertical when the function of the beam is the resistance of external work.

When the unit-stress increases from S_1 up to S , the resilience which can be obtained when the load is lessened so that S decreases to S_1 may be found by replacing S^2 in the above formulas by $S^2 - S_1^2$, as the discussion in Art. 119 shows.

Prob. 121*a*. Deduce an expression for the resilience of a rectangular beam fixed at both ends and uniformly loaded; also when fixed at one end and supported at the other.

Prob. 121*b*. Compute the horse-power required to deflect, 50 times per second, a wrought-iron cantilever beam, $2 \times 3 \times 72$ inches, so that at each deflection the unit-stress S may range from 5 000 to 10 000 pounds per square inch.

ART. 122. RESILIENCE IN SHEAR AND TORSION

The elastic resilience of a body under the action of shear is governed by similar laws to that of tension and flexure, namely,

it is proportional to the square of the maximum unit-stress and to the volume of the body. Thus in Fig. 122 let a vertical shear act upon a parallelopiped of length l and section area a , deforming it into a rhombopiped. The figure represents a short beam with a load P

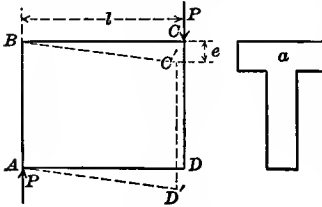

Fig. 122

at the end, so that the shear in every vertical section is equal to P , and the shearing unit-stress is $S_s = P/a$. The external work done by the load P , supposing it to be gradually applied, is $\frac{1}{2}Pe$, where e is the distance through which P deflects. This work is stored in the body in the form of stress energy, and is equal to its elastic resilience. Now $P = aS_s$ and from (15) the unit-detrusion is $e = (S_s/F)l$, where F is the shearing modulus of elasticity. Therefore

$$K = \frac{1}{2}Pe = \frac{1}{2}(S_s^2/F)al \tag{122}$$

is the resilience or the work obtainable from the stored energy when the load P is removed provided the unit-stress S_s is not greater than the shearing elastic limit of the material.

The resilience of a shaft under torsion can be determined in a manner similar to that of beams. When a round shaft is twisted by a force P acting with a lever arm p , as in Fig. 90, each element δa of the section is subject to a shearing unit-stress S_s and to a total stress $S_s \cdot \delta a$. The internal energy or resilience for this element is then $\frac{1}{2}S_s \delta a \times e$, where e is the deformation caused by the shear. Since $e = (S_s/F)l$ is the deformation in the distance l , the internal energy stored in the element of area δa and length δx is,

$$\delta K' = \frac{1}{2}S_s \delta a \cdot (S_s/F)l = \frac{1}{2}(S_s^2/F)l \cdot \delta a$$

Now let S be the shearing unit-stress at the circumference most remote from the axis, and let c be its distance from that axis;

also let z be the distance of δa from the axis. Then, since the stresses vary as their distance from the axis, S_s equals $S \cdot z/c$. Inserting this in the above expression and integrating it over the cross-section, $\Sigma \delta a \cdot z^2$ is replaced by J , the polar moment of inertia, or by ar^2 , where r is the polar radius of gyration. Thus are found,

$$K = \frac{1}{2}(S^2/F)lJ/c^2 \quad \text{or} \quad K = \frac{1}{2}(S^2/F)(r/c)^2 al$$

for the internal energy or resilience of the shaft. Now al is the volume of the shaft, and it is thus seen that the resiliences of circular shafts are proportional to their volumes. Hence the resilience of a shaft under torsion is governed by laws similar to those of a beam under flexure (Art. 121).

The formula here established is only valid when the greatest unit-stress S does not surpass the elastic limit for shearing. When S corresponds to the elastic limit, the quantity $\frac{1}{2}S^2/F$ may be called the modulus of resilience for torsion or shearing, in analogy to the modulus of resilience for tension or compression (Art. 120).

As an example, let it be required to find the work necessary to stress a steel shaft 12 inches in diameter and 30 feet long up to its shearing elastic limit of 30 000 pounds per square inch. Here $S = 30\,000$ and $F = 11\,200\,000$ pounds per square inch (Art. 93); also, $c = 6$ inches, $a = 113.1$ square inches, $J = \frac{1}{32}\pi d^4 = \frac{1}{8}ad^2 = 2036$ inches⁴, $l = 360$ inches. Inserting all values, K is found to be 818 000 inch-pounds or 68 200 foot-pounds; to produce this stress in the shaft in one minute, more than 2 horse-powers are required.

The resilience of a shaft under torsion is measured by the work required to produce a given unit-stress S , and from the above discussion this is seen to vary with $(r/c)^2$. To compare the resilience of a hollow shaft of outside diameter d and inside diameter d_1 with that of a solid shaft having the same section area, it is hence only necessary to compare their values of r^2/c^2 . Let d_2 be the diameter of the solid shaft; then for the two cases,

$$r^2/c^2 = (d^2 + d_1^2)/2d^2 \quad r^2/c^2 = \frac{1}{8}d_2^2/\frac{1}{4}d_2^2 = \frac{1}{2}$$

and accordingly, representing the ratio d_1/d by κ , there is found,

$$\text{hollow/solid} = (\kappa^2 + 1)/\kappa^2$$

which is the ratio of the resilience of a hollow shaft to a solid one of the same section area. If the outer diameter of the hollow shaft is double the inner diameter, the resilience of the hollow shaft is 25 percent greater than that of the solid one.

Prob. 122*a*. Compare the resiliences of a solid shaft 16 inches in diameter with that of a hollow shaft 18 inches in outside and 8 inches in inside diameter.

Prob. 122*b*. A simple beam of section area a and span l has a load P at the middle. Show that the resilience due to the vertical shears is $P^2l/8aF$.

ART. 123. DEFLECTION UNDER ONE LOAD

By the help of the preceding principles regarding work, a method will now be established by which the internal energy stored in a beam may be expressed in terms of the bending moments. Using the same notation as in Arts. 40, 41, the horizontal unit-stress at any distance z above or below the neutral axis is $S \cdot z/c$. In the horizontal distance δx the change of length due to this unit-stress is by (10) known to be $(Sz/cE)\delta x$. The elementary work of a fiber of area δa under the gradually applied unit-stress hence is $\frac{1}{2}(Sz/c)\delta a(Sz/cE)\delta x$. Accordingly the work δK stored in all the fibers of the cross-section in the distance δx is found by summing the works of all the fibers. Noting that $\int \delta a \cdot z^2$ is the moment of inertia I , and that the value of S/c is M/I from the flexure formula (41), there is found,

$$\delta K = \frac{M^2 \delta x}{2EI} \quad \text{or} \quad K = \int \frac{M^2 \delta x}{2EI}$$

the second of which gives the total stored energy. By expressing the bending moment M as a function of x and integrating the expression over the entire length of the beam, K can be found for any particular case.

For example, consider a cantilever beam loaded at the end with P . Here $M = -Px$, and inserting this and integrating

between the limits 0 and l gives $K = P^2 l^3 / 6EI$ for the total stored energy due to a load gradually applied at the end. Again consider a cantilever beam loaded uniformly with w per linear unit; here $M = -\frac{1}{2}wx^2$, whence by integrating results $K = w^2 l^5 / 40EI$; or if W is the total uniform load, $K = W^2 l^3 / 40EI$, which is $\frac{3}{8}$ of that caused by the same load applied at the end.

The formula (123) furnishes a new and convenient method of determining the elastic deflection of a beam under a single load P . Let f be the deflection under the load. Then $\frac{1}{2}Pf$ is the external work done by P as it gradually increases from 0 up to the value P , and this must equal the stored energy K , whence,

$$\frac{1}{2}Pf = K \quad \text{or} \quad Pf = \int \frac{M^2 \delta x}{EI} \quad (123)$$

gives the deflection under the load. For example, take a simple beam loaded at the middle with P ; the value of M is $\frac{1}{2}Px$, and the total integral is twice the integral taken between the limits 0 and $\frac{1}{2}l$. Accordingly,

$$Pf = 2 \int_0^{\frac{1}{2}l} \frac{P^2 x^2 \delta x}{4EI} \quad \text{whence} \quad f = \frac{P l^3}{48EI}$$

which is the same result as that deduced in Art. 55 by the use of the equation of the elastic curve.

The deflection of the metal part of the flitched beam of Fig. 112*b*, when the length of the metal is less than that of the timber, can readily be found by the use of (123). Let l be the span of the simple beam and κl the distance from each end of it to the end of the metal plate. Let P_2 be the single load at the middle which is borne by the metal, then $M = \frac{1}{2}P_2 x$, but in the integration the limits must be between $\frac{1}{2}l$ and κl . Let I be the moment of inertia of the metal section and E the modulus of elasticity of the metal. Then,

$$P_2 f = 2 \int_{\frac{1}{2}l}^{\kappa l} \frac{P_2^2 x^2 \delta x}{4EI} \quad \text{whence} \quad f = \frac{P_2 l^3 (1 - 8\kappa^3)}{48EI}$$

is the deflection of the metal at the middle of the beam, and the statement made in the last paragraph of Art. 112 is therefore justified.

The above method is not applicable to the determination of

the deflection at any point of a beam, except that under the single load P , nor can it be used for several single loads or for a uniform load. The method to be pursued in such cases is developed in the next article.

Prob. 123. Deduce, by the above method and also from Case III of Art. 55, the deflection under a single load P which is placed on a simple beam at a distance $\frac{1}{4}l$ from the left support.

ART. 124. DEFLECTION AT ANY POINT

Consider a beam of any kind, loaded in any manner, and let it be required to find the deflection at a given point. Let a weight P be imagined to be put at this point, this being either a part of the weight of the beam concentrated there or a single load supposed to be there. The deflection at this point due to all the loads on the beam being f , the work of the weight P is $\frac{1}{2}Pf$ and this must equal the internal energy throughout the beam due to that weight P .

Let x be the distance of any section of the beam from an assumed origin, S the unit-stress on the extreme fiber of this section at the distance c from the neutral axis, and $(S \cdot z/c)\delta a$ the stress on a fiber of area δa at a distance z above or below the neutral axis, both of these being due to all the loads on the beam. Let s and $s \cdot z/c$ be the corresponding unit-stresses due to the weight P ; the change of length in the fiber of area δa in the horizontal distance δx , due to the weight P , is $(sz/cE)\delta x$, and the work in this fiber due to P is $\frac{1}{2}(Sz/c)\delta a(sz/cE)\delta x$. The summation of all values of this product, first throughout the section and secondly throughout the length of the beam, gives the internal energy due to P . Now $\sum \delta a \cdot z^2$ is the moment of inertia I ; the value of S/c is M/I , where M is the bending moment due to all the loads on the beam, and the value of s/c is m/I , where m is the bending moment due to the weight P . Accordingly, equating the external work to the internal energy, and extending the integration over the length of the beam, there results,

$$Pf = \int \frac{Mm\delta x}{EI} \quad \text{or} \quad f = \int \frac{MM'\delta x}{EI} \quad (124)$$

both of which give the deflection f at any point of the beam; in the first M is the bending moment due to any weight P at that point; in the second M' is the bending moment due to the weight unity at that point. By inserting for M and M' their values in terms of x , and integrating, the deflection f is readily found.

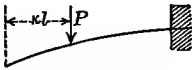

Fig. 124a



Fig. 124b

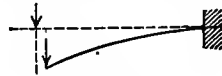

Fig. 124c

For example, let it be required to find the deflection at the end of a cantilever beam due to a load P placed at a distance κl from the left end, as in Fig. 124a. On the left of the load $M=0$, and on the right of the load $M=-P(x-\kappa l)$, where x is measured from the free end. Placing a weight unity at the end, the bending moment due to it is $M'=-x$ throughout the entire length of the cantilever. Thus $MM'=0$ on the left of the given load and $MM'=P(x^2-\kappa lx)$ on the right. The formula then furnishes,

$$EI f = \int_{\kappa l}^l P(x^2 - \kappa lx) \delta x = \frac{1}{6} P l^3 (2 - 3\kappa + \kappa^3)$$

which gives the deflection of the end due to P . When $\kappa=0$, the load is at the end and $f = P l^3 / 3EI$, as otherwise found in Art. 54.

As a second example, let it be required to find the deflection of the right end of the overhanging beam in Fig. 124b, the load being uniform throughout. Let l be the span and κl the length of the overhanging arm. The left reaction due to the uniform load is $\frac{1}{2} w l (1 - \kappa^2)$, whence $M = \frac{1}{2} w l (1 - \kappa^2) x - \frac{1}{2} w x^2$ for the span l ; for the overhanging arm let x be any distance from the right end, then $M = \frac{1}{2} w x^2$. For a weight unity at the end of the overhanging arm, the left reaction is $-\kappa$, whence $M' = -\kappa x$ for the span l ; for the overhanging arm $M' = x$. The deflection formula then gives

$$EI f = - \int_0^l \frac{1}{2} w (\kappa l x^2 - \kappa^3 l x^2 - \kappa x^3) \delta x + \int_0^{\kappa l} \frac{1}{2} w x x^3 \delta x = - \frac{1}{24} w l^4 (\kappa - 4\kappa^3 - 3\kappa^4)$$

from which f is known for any value of κ . For instance, let $\kappa = \frac{1}{4}$, then $f = -15 w l^4 / 2048 EI$, the minus sign showing that the deflec-

tion is upward, because at the beginning of this article positive values of f were measured downward. For a longer overhanging arm, however, f may be positive; this is the case when $\kappa = \frac{1}{2}$.

When a cantilever beam deflects, the free end suffers a horizontal displacement which may be derived from (124), taking the force unity as horizontal, and using the equation of the elastic curve. For Fig. 124c, where the load P is at the end, the elastic curve has the equation $y = f_1(2l^3 - 3l^2x + x^3)/2l^3$, where f_1 is the vertical deflection under the load (Art. 54). Now let the horizontal force unity be applied to the free end where the horizontal displacement is f ; its moment is $M' = -(f_1 - y)$ and the moment of P is $M = -Px$. Then the formula (124) becomes,

$$EI f = P \int_0^l (f_1 - y) x \delta x = (P f_1 / 2l^3) \int_0^l (3l^2 x^2 - x^4) \delta x$$

from which the horizontal displacement of the end of the beam may be found to be $f = 6f_1^2/5l$, which is very small compared with the vertical deflection of the end.

The above examples show the great value of formula (124) in discussing all questions regarding the elastic deflections of beams. It may be used to find the equation of the elastic curve also, taking f as the ordinate corresponding to the abscissa x . It applies, however, only to cases where the greatest flexural unit-stresses do not exceed the elastic limit of the material. When I is not constant, it is to be expressed as a function x before the integration can be made.

Prob. 124a. Find by the above method the equation of the elastic curve for a simple beam uniformly loaded, and compare it with that deduced in Art. 55.

Prob. 124b. A simple beam has two equal concentrated loads placed at equal distances from the supports. Deduce the deflection under one of the loads, and also the deflection at the middle of the beam.

ART. 125. DEFLECTION DUE TO VERTICAL SHEAR

The treatment of the deflection of beams in the previous pages has been solely from the standpoint of the horizontal

stresses caused by the external bending moment. Art. 122 shows, however, that internal energy is stored in a beam by a vertical shear, and it hence appears that the former investigations are more or less incomplete in neglecting the deformation which is caused by the external vertical shears.

Referring to Fig. 125 let V be the vertical shear which has produced the vertical detrusion δf in the short length δx . Let a be the section area of the beam, F the shearing modulus of elasticity. The shearing unit-stress in the section is V/a and this will be considered as uniformly distributed. The internal work in the length δx is $\frac{1}{2}V \cdot \delta f$ when V increases gradually from 0 up to V . Now from the definition of F in Art. 15 it is known that $\delta f = (V/aF)\delta x$, since $\delta f/\delta x$ is the unit-detrusion that is due to the unit-shear V/a . Accordingly the whole internal energy due to shear in the length δx is $\delta K = \frac{1}{2}(V^2/aF)\delta x$. When f is the deflection under a single load P , the external work is $\frac{1}{2}Pf$. Accordingly,

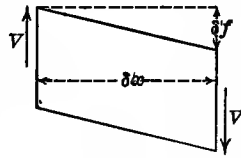

Fig. 125

$$K = \frac{1}{2} \int \frac{V^2 \delta x}{Fa} \quad \text{and} \quad Pf = \int \frac{V^2 \delta x}{Fa} \quad (125)$$

are expressions for the total internal energy due to shearing, and the deflection f under a single load P .

For instance, a simple beam with a load P at the middle has the shear $V = \frac{1}{2}P$. Then by taking double the integral between the limits 0 and $\frac{1}{2}l$ there is found $K = P^2 l / 8Fa$ for the internal energy or resilience due to the shears throughout the beam. The deflection under the load due to the vertical shear then is $f = Pl / 4Fa$. In Art. 55 the deflection due to the bending moments was found to be $Pl^3 / 48EI$. Accordingly the ratio of the shearing deflection to that of the flexural deflection is $12EI / Fa l^2$, which reduces to $12(E/F)(r/l)^2$, where r is the radius of gyration of the section. For a cast-iron beam the ratio E/F is about 2.5; if the section is square the ratio of the shearing to the flexural deflection is $2.5(d/l)^2$, where d is the side

of the square; when the length of the square beam is 30 times its side, this ratio is $\frac{1}{340}$, so that the deflection due to shearing is small compared with that due to the moments; for a short beam, such as $l=2d$, this ratio is 0.625, so that the deflection due to shearing is $62\frac{1}{2}$ percent of that due to the moments.

In 1870 Norton called attention to the inaccuracy of the ordinary formula for deflection in the case of short beams. Experiments on white-pine beams of different lengths and sizes were made with loads at the middle of the spans, and it was shown that the deflections were directly proportional to the loads and inversely proportional to the breadth of the beam, as the common formula requires. The deflections were, however, not directly proportional to the cubes of the spans nor inversely proportional to the cubes of the depths of the beams, as the formula requires. An examination into the reason of these discrepancies showed that it was due to influence of the vertical shears, and Norton showed that the quantity $C \cdot Pl/bd$ should be added to the common flexure formula in order to satisfy the results of his experiments; he further showed that the quantity C had the value 0.0000094 for the white-pine beams. From the theoretic value deduced in the last paragraph it is seen that $4F$ is the reciprocal of this number, whence $F=266\ 000$ pounds per square inch, which should be the modulus of elasticity for the shearing of white pine across the grain. This is probably not far from the actual value of that coefficient, since Thurston, by experiments on torsion, found $F=220\ 000$ pounds per square inch for white pine. The experiments of Norton, therefore, confirm the above theory of the deflection of beams due to shearing.

Formula (125) does not apply to the deflection at any point, or to any kind of loading except a single load P . For any other case let any weight P be at the point where it is desired to find the deflection, and let v be the shear due to this weight. The external work due to P is $\frac{1}{2}Pf$, where f is the required deflection. The internal work in any elementary distance δx is one-half of the product of the actual shear V and the detrusion $(v/aE)\delta x$. Therefore

$$\frac{1}{2}P f = \int \frac{V_V}{2Fa} \delta x \quad \text{or} \quad f = \int \frac{V V'}{Fa} \delta x \quad (125)'$$

are expressions for finding the deflection due to shearing; in the first v is the shear due to any weight P and in the second V' is the shear due to the weight unity at the point where the deflection is desired.

For example, take the case of Fig. 124*a* and let it be required to find the deflection at the end due to shearing when a single load P is at the distance κl from the left end. Let x be measured horizontally from the free end where the weight unity is placed. Then $V=0$ on the left of the load and $V=-P$ on the right of the load, while $V'=-1$ throughout the beam. Then from (125)',

$$F a f = \int_{\kappa l}^l P \delta x = P l (1 - \kappa) \quad \text{or} \quad f = (1 - \kappa) P l / F a$$

gives the deflection at the end due to the vertical shears. When $\kappa=0$, the load P is at the end and $F=Pl/Fa$; the ratio of this to the deflection due to the moments is $3(E/F)(r/l)^2$. This shows that the deflection due to the shears is scarcely appreciable in long beams; for short beams, however, it may be larger than that due to the moments.

By measuring the elastic deflections of two beams of different lengths but of the same material, it is possible to compute the values of E and F for that material. The deflections thus measured are due both to moments and shears and hence an expression for each measurement is to be written in terms of E and F . Let l_1 and l_2 be the spans, a_1 and a_2 the section areas, I_1 and I_2 the moments of inertia, and P_1 and P_2 the loads at the middle of the simple beams. Let the measured deflections be f_1 and f_2 . Then may be written,

$$\frac{P_1 l_1^3}{48 I_1} \frac{1}{E} + \frac{P_1 l_1}{4 a_1} \frac{1}{F} = f_1 \quad \frac{P_2 l_2^3}{48 I_2} \frac{1}{E} + \frac{P_2 l_2}{4 a_2} \frac{1}{F} = f_2$$

which contain the two unknown quantities $1/E$ and $1/F$, and hence the solution of the two equations will furnish the values of the common modulus E and the shearing modulus F . By making many experiments instead of two, writing an equation for each, and solving the equations by the method of Least Squares,

it is possible to obtain reliable values of these moduluses of elasticity. In such experiments it is of course important that the loads should not be heavy enough to stress the material beyond its elastic limit.

In conclusion it may be noted that there is an elastic curve due to vertical shears, and its equation may be used in similar manner to that of the bending moments. From Fig. 125, the general equation of this elastic curve is,

$$\frac{\delta y}{\delta x} = \frac{V}{aF} \quad \text{or} \quad aF \frac{\delta y}{\delta x} = V$$

For example, let it be required to find the elastic curve and the deflection due to vertical shears for a simple beam of span l loaded uniformly with w per linear unit. Here $V = \frac{1}{2}wl - wx$, and inserting this in the general equation and integrating there is found $aFy = \frac{1}{2}w(lx - x^2)$ for the equation of the elastic curve. The maximum deflection occurs at the middle where $x = \frac{1}{2}l$, and its value $f = wl^2/8aF$, and this agrees with the result which will be found by the use of (125)'.

Prob. 125*a*. Find the deflection of the end of the overhang in Fig. 124*b* due to the vertical shears of the uniform load.

Prob. 125*b*. A timber beam 9 inches long and 2 inches square is placed on supports 7 inches apart and subject to deflection by a load of 300 pounds at the middle. Compute the amount of the deflection due to the vertical shears and that due to the bending moments.

ART. 126. PRINCIPLE OF LEAST WORK

There is a certain law of nature called the principle of least work, which is of great value in discussing problems in mechanics that cannot be solved by static conditions alone. For example, a table with four legs is a system where the reactions of the legs, due to an unsymmetric load on the table, cannot be found by statics, since the three conditions of static equilibrium cannot determine four unknown quantities. The principle of least work furnishes, however, a fourth condition when the stresses in the legs do not exceed the elastic limit of the material.

When a structure is so formed that the stresses in it cannot be determined by statics, it is said to be a "redundant system", and the principle of least work applicable to it is as follows:

The stresses in a redundant system have such values that the internal energy of all the stresses is a minimum.

This is sometimes regarded as an axiom, it being considered that the resisting forces will store up no more energy than the minimum which is necessary to maintain equilibrium with the external forces. The following proof, however, will probably be more satisfactory than the assumption of the axiom. Let P_1, P_2, \dots, P_r be r forces in equilibrium, and let a small displacement be made, without performing work on the system, so that the points of application of these forces move through the small distances $\delta e_1, \delta e_2, \dots, \delta e_r$. Then the total work done must be equated to zero, or,

$$P_1\delta e_1 + P_2\delta e_2 + P_3\delta e_3 + \dots + P_r\delta e_r = 0$$

and for all cases of stable equilibrium it is a law of mechanics that the integral of this shall be a minimum, or,

$$P_1e_1 + P_2e_2 + P_3e_3 + \dots + P_re_r = \text{a minimum}$$

in which e_1, e_2, \dots, e_r are the total distances through which the forces have moved in acquiring the state of stable equilibrium. Now each of the quantities Pe is double the work done by the applied force P as it increases from 0 to P , and hence also equal to double the energy stored by the stresses that balance it. Therefore, the internal work or stored energy of all the resisting stresses is a minimum.

When forces act upon elastic bodies, in which the deformations are proportional to the stresses, the above principle of least work may be applied to determine unknown reactions when the conditions of statics are not sufficient in number to do so. Many problems of fixed and continuous beams may be discussed by the aid of this principle. For example, take a continuous beam of two equal spans loaded uniformly in the second span, as in Fig. 126*a*, and let it be required to find the three reactions R_1, R_2, R_3 . The first condition of statics is that the sum of the reactions equals the total load, or $R_1 + R_2 + R_3 = W$; the

second condition is that the sum of the moments of the reactions equals the moment of the load, whence, for an axis at the right end, $2R_1l + R_2l = \frac{1}{2}Wl$. The third condition is that the internal energy of all the flexural stresses shall be a minimum. For the first span the bending moment at the distance x from the left support is $M = R_1x$; for the second span the moment at the distance x from the right support is $M = R_3x - \frac{1}{2}wx^2$. Then, by Art. 123, the total internal energy of the horizontal flexural stresses is,

$$K = \int_0^l \frac{(R_1x)^2}{2EI} \delta x + \int_0^l \frac{(R_3x - \frac{1}{2}wx^2)^2}{2EI} \delta x$$

$$= \frac{l^3}{120EI} (20R_1^2 + 20R_3^2 - 15R_3W + 3W^2)$$

Differentiating this, and equating the derivative to zero, gives the equation $8R_1 \cdot \delta R_1 + 8R_3 \delta R_3 - 3W \cdot \delta R_3 = 0$ as the condition of least work. Solving the three equations thus established, there result $R_1 = -\frac{1}{8}W$, $R_2 = +\frac{3}{4}W$, $R_3 = +\frac{3}{8}W$ for the reactions due to the given load; these are the same results as derived by the use of the theorem of three moments (Art. 71).

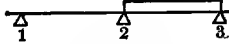

Fig. 126a

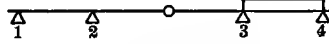

Fig. 126b

As a second example, take the partially continuous girder in Fig. 126b which has four supports and a joint at the middle of the second span so that the bending moment there is always zero. Let $2l$ be the length of the middle span and l that of each end span, and let it be required to find the four reactions due to a uniform load in the last span. Three conditions are,

$$R_1 + R_2 + R_3 + R_4 = W \quad 4R_1 + 3R_2 + R_3 = \frac{1}{2}W \quad 2R_1 + R_2 = 0$$

the first being the static condition that the sum of the vertical forces is zero; the second the static condition that the sum of the moments of these forces is zero, the axis being taken at the right end; the third the condition that there is no moment at the joint. From these three conditions the values of three reac-

tions may be found in terms of the other reaction, thus,

$$R_2 = -2R_1 \quad R_3 = \frac{1}{2}W + 2R_1 \quad R_4 = \frac{1}{2}W - R_1$$

and the value of R_1 may be found by the help of the principle of least work. To do this an expression for the bending moment is found for each of the four parts of the beam and the sum of all the values of $M^2/2EI$ will give the total internal work of the flexural stresses (Art. 123). Thus, in a manner similar to that of the last paragraph, a fourth condition is established which expresses that the work of the internal stresses is a minimum. This equation, in connection with the three previously established, gives $R_1 = -\frac{1}{3}W$, $R_2 = +\frac{2}{3}W$, $R_3 = +\frac{4}{3}W$, $R_4 = +\frac{1}{3}W$. These are the reactions for the given uniform load due to the bending moments, and they will be slightly modified if the vertical shears are taken into account.

Examples of the application of the principle of least work to bridges and arches will be found in Parts I and IV of Roofs and Bridges. This principle must be used with caution by the beginner, but it is one of much value in the discussion of structures which are statically indeterminate.

Prob. 126. A table of length l and width h has four legs at the corners which are of equal size and length. For a load P placed on the table at a distance $\frac{1}{4}l$ from the side h and a distance $\frac{1}{4}h$ from the side l , compute the reactions of the leg nearest the load.

CHAPTER XIV

IMPACT AND FATIGUE

ART. 127. SUDDEN LOADS AND STRESSES

A load at rest on a bar or beam is called a 'static load'. The same term is applied to a load which increases from 0 up to its final value P in such a way that the deformations of the bar or beam at different instants are proportional to the loads acting at those instants until the elastic limit of the material is exceeded. Loads applied in any other manner are sometimes called 'dynamic', and the term "impact" implies either suddenness of action or that the load is in motion before it is applied to the bar or beam. Static loads have been mostly considered in the preceding chapters, but it has always been recognized that the stresses and deformations due to sudden and variable loads are greater than for static ones (Art. 7). The terms 'dynamic stress' and 'dynamic deformation' are sometimes used to distinguish the effects of impact from those due to static loads.

A static tensile load is usually applied to a bar by increments, so that it increases from 0 up to P in such a way that the elongation is proportional to the load until the elastic limit of the material is reached. The work done upon the bar is then equal to the mean load $\frac{1}{2}P$ multiplied by the elongation e , or $K = \frac{1}{2}Pe$. Simultaneously the stress in the bar increases from 0 up to P and the internal energy stored in the bar is $\frac{1}{2}Pe$. The triangle in Fig. 127*a* represents both the external work and the internal energy.

When a load is applied to a bar in such a manner that its intensity is the same from the beginning to the end of the elongation, it is called a "sudden load". For instance, let a load be hung by a cord and just touch a scale-pan at the foot of a vertical bar; then if the cord is quickly cut, the load acts upon the bar with uniform intensity throughout the entire elongation. In

this case the maximum elongation is greater than for a static load, but the bar at once springs back, carrying the load with it, and a series of oscillations ensues, until finally the bar comes to rest with an elongation due to the static load. Here the stress in the bar increases from 0 up to Q , the stress Q being equal to the static load which would produce the maximum elongation. Fig. 127*b* represents this case, where the rectangle shows the work done by the instantaneous load P , and the triangle shows the internal energy stored in the bar at the instant of greatest elongation. The unit-stress due to Q must be less than the elastic limit in order that the following discussions may be valid.

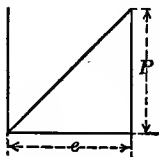
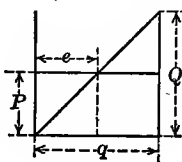
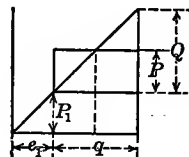
Fig. 127*a*Fig. 127*b*Fig. 127*c*

Let q be the maximum elongation due to the sudden load P ; the work performed in the bar is Pq . The internal energy stored in the bar at the instant of greatest elongation is $\frac{1}{2}Qq$, since the stress increases from 0 up to Q . Hence $\frac{1}{2}Qq = Pq$, or $Q = 2P$. Let e be the elongation due to the static load P ; then $q/e = Q/P$, and hence also $q = 2e$. Accordingly the following important law is established for a bar under elastic changes of length:

A sudden load produces double the stress and double the deformation that is caused by a static load.

Fig. 130*a* shows the end of a bar acted upon by a sudden load and it will be explained in Art. 132 that the maximum velocity of the load occurs when the elongation is equal to e ; the curve in the figure shows the variations in velocity. When the elongation $2e$ is reached, the stress in the bar is $2P$ and the resultant force tending to move the end is $P - 2P$ or $-P$; hence the end moves backward and oscillations ensue, until finally the bar comes to rest under the elongation e and the stress P .

In the above discussion P and Q are the total stresses on the section area a of the bar. Let S and T be the corresponding unit-stresses, so that $P=Sa$ and $Q=Ta$. Then the equation $Q=2P$ becomes $T=2S$, that is, the unit-stress due to a sudden load is double that due to the same static load.

Similar conclusions result when a single load P is suddenly applied to a beam producing the deflection q while under the same static load the deflection is f . Let Q be the static load which will produce the deflection q . Then the external work of this static load is $\frac{1}{2}Qq$, while that of the sudden load is Pq ; hence $\frac{1}{2}Qq=Pq$ or $Q=2P$; that is, the sudden load P produces the same effect as a static load $2P$. From the static law $Q/P=q/f$, it follows that $q=2f$, so that the dynamic deflection is double the static deflection. Let S be the flexural unit-stress at the dangerous section of the beam when the deflection is f and let T be the unit-stress when the deflection is q ; then $q/f=T/S$, since elastic deflections are proportional to the unit-stresses (Art. 2). Therefore also, $T=2S$, that is, the flexural unit-stress due to a sudden load is double that due to the same static load.

Lastly, consider a bar upon which rests a load P_1 causing the elongation e_1 . Let a sudden load P be now brought upon it causing the additional elongation q and the additional stress Q . Fig. 127*c* represents this case and it shows that the elongation is e_1+2e and that the final stress is P_1+2P ; thus the instantaneous load produces its effect independently of the other. As soon as the elongation e_1+2e occurs, the bar springs back, and a series of oscillations follows; finally the bar comes to rest under the elongation e_1+e and the stress P_1+P . Similar conclusions follow in the case of a beam under an initial load.

In the above investigation it has been supposed that all the work Pq performed by the sudden load P is expended in storing energy in the bar or beam. This is not strictly the case, for internal molecular friction causes a slight loss of work (Art. 147). The law deduced is, however, very close for a light beam, but Q is really a little less than $2P$ and q is a little less than $2e$ when the beam is heavy compared with the load.

Prob. 127. A vertical steel bar, 2 inches in diameter and $1\frac{1}{2}$ feet long, has a load of 15 000 pounds hung at its end. Compute the elongation due to this static load, and also the maximum elongation which occurs when an additional load of 7 500 pounds is suddenly applied.

ART. 128. AXIAL IMPACT ON BARS

The word impact is here used to mean the effect of a load which is moving when it strikes the end of a bar; such a load evidently produces a greater deformation and a greater stress than one applied suddenly. The stress in the bar increases from 0 up to a certain limit Q and the deformation increases from 0 up to q . If the elastic limit of the material is not exceeded, the stress at any instant is proportional to the deformation so that the stored energy of the internal stresses is $\frac{1}{2}Qq$. Equating this to the external work, the values of Q and q may be found.

Let P be a weight which is moving horizontally with the velocity V at the instant it strikes the end of a light horizontal bar. Its kinetic energy is $P \cdot V^2/2g$, where g is the acceleration of gravity; or, if h is the height through which P has fallen to acquire the velocity V , then $V^2/2g=h$, and the kinetic energy of the moving weight is $P \cdot h$. Accordingly $\frac{1}{2}Qq=Ph$, if no work is expended in overcoming inertia or in friction. Now, let e be the elongation of the bar due to the static load P ; then the law of proportionality gives $q/e=Q/P$. From these two equations are found,

$$Q=P(2h/e)^{\frac{1}{2}} \quad q=e(2h/e)^{\frac{1}{2}}=(2he)^{\frac{1}{2}} \quad (128)$$

which shows that Q may be much greater than P and q much greater than e when the weight P is moving rapidly. For example, let $V=10$ feet per second, then $h=100/2 \times 32.2=1.55$ feet = 18.6 inches. Let the weight P be 60 pounds and the horizontal bar be of steel 18 feet long and 3 square inches in section area, then (10) gives $e=Pl/aE=0.000144$ inches. Accordingly, $Q=30500$ pounds and $q=0.073$ inches, which are about 510 times as great as those due to a static load of 60 lbs.

When a vertical bar is subject to the impact of a falling weight

P , the end of the bar is elongated or shortened the amount q so that the work performed upon it is $(P(h+q))$. The internal stored energy is $\frac{1}{2}Qq$ as before. Accordingly the two equations $\frac{1}{2}Qq=P(h+q)$ and $q/e=Q/P$ are to be used to find the values of Q and q , which are,

$$Q = P + P(1 + 2h/e)^{\frac{1}{2}} \quad q = e + e(1 + 2h/e)^{\frac{1}{2}} \quad (128)'$$

When $h=0$, these formulas reduce to $Q=2P$ and $q=2e$, which are the results previously found for a sudden load. Since e is a small quantity, it follows that a load dropping from a moderate height may produce large stresses and deformations. Experiments made upon elongations of spiral springs give results which closely agree with those computed from the formula for q , when the elastic limit is not surpassed by the stress Q . The curve in Fig. 130*b* shows the variation in velocity of the end of the bar.

The effect of loads applied with impact is therefore to cause stresses and deformations greatly exceeding those produced by the same static loads, so that the elastic limit may perhaps be often exceeded. Moreover the rapid oscillations which ensue cause a change in molecular structure which impairs the elasticity of the material when such loads are often applied. It is sometimes found that the appearance of a fracture of a bar which has been subject to shocks is of a crystalline nature, whereas the same material, if ruptured under a gradually increasing stress, would exhibit a tough fibrous structure. Moving loads which produce stresses above the elastic limit cause the wrought iron and steel to become stiff and brittle, and hence it is that the working unit-stresses should be taken very low (Art. 7).

The above formulas apply also to unit-stresses. Let a be the section area of the bar, S the unit-stress due to the static load P and T the unit-stress due to Q , so that $S=P/a$ and $T=Q/a$. Then the formulas for Q in (128) and (128)' become,

$$T = S(2h/e)^{\frac{1}{2}} \quad T = S + S(1 + 2h/e)^{\frac{1}{2}} \quad (128)''$$

the first of which applies to a horizontal bar and the second to a vertical bar. For instance let $h=18e$, then $T=6S$ for the horizontal and $T=7.08S$ for the vertical bar. Here T is the unit-

stress which prevails in the bar at the instant of greatest deformation, but after a series of oscillations the bar comes to rest under the unit-stress S . These oscillations are discussed in Art. 132.

All of the above formulas for dynamic stress and elongation give results which are somewhat too large, because a portion of the energy of the moving weight P is expended in overcoming the inertia of the bar. They apply only to bars which are so light that this resistance of inertia may be disregarded. In Art. 130 it will be shown how these formulas may be modified so as to take into account the inertia of the bar.

Prob. 128. In an experiment upon a spring, a static load of 14.79 ounces produced an elongation of 0.42 inches, but when dropped from a height of 7.72 inches it produced a stress of 102.3 ounces and an elongation of 2.90 inches. Compare theory with experiment.

ART. 129. IMPACT ON BEAMS

When a falling weight strikes a beam, it causes a greater deflection than a load suddenly applied. Let the weight P fall from a height h above a light beam and produce the dynamic deflection q ; the work performed is then $P(h+q)$. Let T be the maximum flexural unit-stress produced by the impact and S be that due to a static load P which causes the deflection f . Then the deflections are proportional to the unit-stresses, if the elastic limit is not exceeded, or $q/f = T/S$. Also let Q be a static load which will produce the deflection q ; then the deflections are also proportional to the loads, or $q/f = Q/P$; accordingly $Q/P = T/S$. The external work of the load Q is $\frac{1}{2}Qq$ and this is equal to the internal energy stored in the beam when the deflection q is attained, if all the work is expended in stressing the beam. Hence $\frac{1}{2}Qq = P(h+q)$, which by the above ratio reduces to $\frac{1}{2}Tq = S(h+q)$. Combining this with $q/f = T/S$, there are found,

$$T = S + S(1 + 2h/f)^{\frac{1}{2}} \quad q = f + f(1 + 2h/f)^{\frac{1}{2}} \quad (129)$$

as the formulas for the dynamic maximum unit-stress and deflection due to the impact of a single load P . Here S is found from

the flexure formula (41) for any given case, or $S = Pcl/\alpha I$, and f is found from the deflection formula $f = Pl^3/\beta EI$, where l is the length of the beam, α and β numbers depending on the arrangement of the ends, I the moment of inertia of the cross-section, c the distance from the neutral axis to the remotest fiber of the dangerous section, and E the modulus of elasticity of the material (Arts. 55 and 63).

When a weight P is moving with the velocity V , it can perform in coming to rest the work $P \cdot V^2/2g$, where g is the acceleration of gravity. When the weight moves horizontally and strikes normally against the side of a beam which has its ends arranged so as to prevent lateral motion, a lateral dynamic deflection results. Let h be the height corresponding to $v^2/2g$, then the external work Ph is to be equated to $\frac{1}{2}Qq$ as before. Hence the equations $\frac{1}{2}Qq = Ph$, in connection with the laws of proportionality, give,

$$T = S(2h/f)^{\frac{1}{2}} \quad q = f(2h/f)^{\frac{1}{2}} = (2hf)^{\frac{1}{2}} \quad (129)'$$

for the unit-stress and lateral deflection at the instant when P comes to rest. This case rarely occurs except in machines for testing materials by impact.

The above formulas are only valid when the unit-stress T is less than the elastic limit of the material. When the load P is light compared to the weight of the beam, they give results which are somewhat too large, because a part of the work due to P is expended in overcoming the inertia of the beam (Art. 131). It will be noted that these formulas are the same as those found in Art. 128 for bars, except that the static deflection f appears instead of the static elongation e .

Prob. 129*a*. A cast-iron simple beam, $1 \times 1 \times 24$ inches, was loaded with a weight of 25 pounds at the middle and the deflection found to be 0.0028 inches. It was then struck horizontally by a hammer weighing 25 pounds which had a vertical fall of 2 inches. Compute the lateral dynamic deflection.

Prob. 129*b*. Compute the deflection of the above beam when a weight of 25 pounds falls vertically upon the middle through a height of 2 inches. The observed deflection in this case being 0.130 inches, what explanation may be given of the smaller computed deflection?

ART. 130. INERTIA IN AXIAL IMPACT

When a moving weight strikes axially upon the free end of a bar, some of its kinetic energy is expended in overcoming the inertia of the particles and putting them into motion, this energy being converted into heat. The load P falling through the height h has the kinetic energy Ph when it touches the end of the bar, but owing to the loss in impact only a part of Ph is effective in elongating and stressing the bar. Let η be a number less than unity, called the 'inertia coefficient', then ηPh is the energy which produces the stress Q and the elongation q in the bar. All the formulas of Art. 128 may hence be applied to heavy bars when the number η is known by replacing h by ηh . The object of this article is to determine the value of η in terms of P and the weight W of the bar. The theory of the impact of inelastic bodies may be used for this purpose with close approximation, since the moving weight and the end of the bar are in close contact during the period of the impact. The velocity with which stress is propagated through the bar will be supposed to be infinite. The greatest unit-stress Q/a , where a is the section area, must not exceed the elastic limit of the material.

As soon as the load P strikes the end of the bar, its velocity V decreases and the end of the bar begins to move. When complete contact is attained, both P and the end of the bar are moving with a velocity v which is less than V , and at this instant any element δW of the bar is moving with a velocity u . Accordingly the kinetic energy stored in the load P and in the bar of length l and weight W at this instant is expressed by,

$$K = P \cdot v^2/2g + \int_0^l \delta W \cdot u^2/2g$$

Now $u = 0$ for the fixed end and $u = v$ for the free end of the bar, and for an infinite velocity of stress u is proportional to the distance y from the fixed end, so that $u = v \cdot y/l$; also the element δW is $W \cdot \delta y/l$. Introducing these values, the integral in the above expression is found to be $\frac{1}{3}W \cdot v^2/2g$ or one-third of the kinetic energy which would obtain if the entire bar were in

motion with the velocity v . Accordingly,

$$K = (P + \frac{1}{3}W)v^2/2g \quad \text{or} \quad K = (\frac{1}{3}W/P)P \cdot v^2/2g$$

is the kinetic energy in the load and bar when the load and the end of the bar are moving with the velocity v .

Now it is known from Newton's second law of motion, that the common velocity of two bodies at the instant of complete contact in the impact is $v = V \cdot P/(P + P_1)$, when the body of weight P moving with the velocity V strikes a free body of weight P_1 which is at rest. For the case in hand, however, one end of the bar is fixed, so that W cannot replace P_1 in this expression. When the free end of the bar is moving with the velocity v , the element δW at the distance y from the fixed end is moving with the velocity $u = v \cdot y/l$ if stress is transmitted instantaneously. Accordingly, instead of $PV = (P + P_1)v$ there must be written,

$$PV = Pv + \int_0^l \delta W \cdot u = Pv + \frac{Wv}{l^2} \int_0^l y \delta y = (P + \frac{1}{2}W)v$$

and hence $v = V/(1 + \frac{1}{2}W/P)$ is the common velocity of the load and the end of the bar. Hence, if h is the height $V^2/2g$, the above expression for K becomes

$$K = \frac{1 + \frac{1}{3}W/P}{(1 + \frac{1}{2}W/P)^2} P \cdot V^2/2g = \eta Ph \quad \eta = \frac{1 + \frac{1}{3}W/P}{(1 + \frac{1}{2}W/P)^2}$$

in which η is the inertia coefficient. When the bar has no weight, then $\eta = 1$ and the entire kinetic energy is effective in elongating and stressing the bar. When the load and bar are of equal weight, then $\eta = \frac{1}{2} \frac{6}{7}$, so that $\frac{1}{2} \frac{6}{7} Ph$ is effective, while $\frac{1}{2} \frac{1}{7} Ph$ is lost in heat.

For the case of horizontal impact in Fig. 130c, the bar is brought into tension by the load P moving with the velocity V . The effective work ηPh is expended in stressing the bar from o up to Q while the elongation increases from o up to q , so that the stored stress energy at the moment of greatest elongation then is $\frac{1}{2}Qq$; hence $\frac{1}{2}Qq = \eta Ph$. Also $q/e = Q/P$ if e is the static elongation due to P . From these two equations the values of Q and q for horizontal impact are found to be,

$$Q = P(2\eta h/e)^{\frac{1}{2}} \quad q = (2\eta h e)^{\frac{1}{2}} \quad \eta = \frac{1 + \frac{1}{3}\rho}{(1 + \frac{1}{2}\rho)^2} \quad (130)$$

in which η is the inertia coefficient and ρ is the ratio W/P . If S is the static unit-stress P/a and T is the dynamic unit-stress Q/a , then also $T=S(2\eta h/e)^{\frac{1}{2}}$. It is seen that the values of Q and T are less than those given by (128) on account of the energy lost in overcoming inertia. For instance let T_1 be the value computed from the first equation in (128)'', then $T_1\eta^{\frac{1}{2}}$ is the value when the resistance of inertia is taken into account; thus when W equals P , the dynamic unit-stress is $0.77T_1$, and when W is equal to $4P$ it is $0.51T_1$.

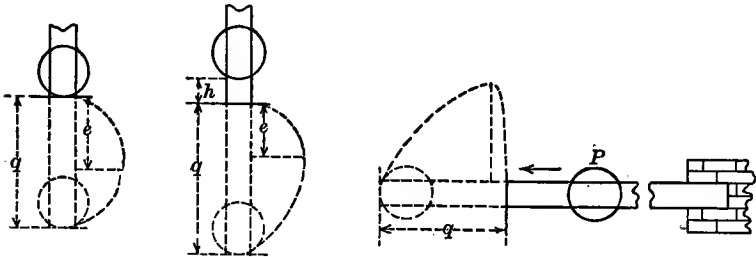

Fig. 130a

Fig. 130b

Fig. 130c

For the case of vertical impact shown in Fig. 130b the weight P falls through the height h upon the end of the bar. Here the equations are the same as in the last paragraph except that Pq is to be added to the second member of the energy equation, since P falls through the distance q after striking the end of the bar, whence $\frac{1}{2}Qq=P(\eta h+q)$. Solving the equations there results,

$$Q=P+P(1+2\eta h/e)^{\frac{1}{2}} \quad q=e+(e^2+2\eta he)^{\frac{1}{2}} \quad (130)'$$

as the formulas for vertical impact in which the impact coefficient η has the value given above. As a numerical example let it be required to find the dynamic stress produced in a vertical wrought-iron bar, two square inches in section area and 18 feet long, by a body weighing 600 pounds and falling through the height of one foot. Here $W=10 \times 6 \times 2=120$ pounds (Art. 17), $\rho=0.2$ and $\eta=0.882$; also $e=Pl/aE=0.00259$ inches; then the formula gives $Q=54\,840$ pounds. The stress due to the static load of 600 pounds is $S=300$ pounds per square inch, but the dynamic stress due to the same load falling through a height of one foot is $T=27\,420$ pounds per square inch or about 90 times as great.

When the load P strikes upon a shelf or scale-pan of weight W_1 at the free end of the bar, the loss of kinetic energy is greater than before, since the inertia of a greater weight must be overcome. Then at the moment of complete contact W_1 has the kinetic energy $W_1 \cdot v^2/2g$ and this must be added to the first value of K in this article; also the equation of impact becomes $PV = (P + W_1 + \frac{1}{2}W)v$. By the same reasoning as before the same equations are deduced, except that the inertia coefficient has the value,

$$\eta = \frac{1 + \rho_1 + \frac{1}{2}\rho}{(1 + \rho_1 + \frac{1}{2}\rho)^2} \quad \rho_1 = \frac{W_1}{P} \quad \rho = \frac{W}{P}$$

For example, take the case of the wrought-iron bar in the last paragraph and let the load of 600 pounds fall in a scale-pan which weighs 300 pounds. Here $\rho_1 = 0.5$, $\rho = 0.2$, and $\eta = 0.612$; then $Q = 45$ 100 pounds, and $T = 22$ 550 pounds per square inch, so that the addition of the scale-pan diminishes the dynamic stress about 18 percent. This is a principle of importance in bridge construction; for example, a heavy floor for a suspension bridge decreases the dynamic stress which may be brought by the live load upon the vertical rods that connect the floor to the cable.

Prob. 130. A weight of 60 pounds impinges upon the end of a horizontal bar of wrought iron which is 2 inches in diameter and 12 feet long. Find the velocity of the weight which will stress the bar up to its elastic limit.

ART. 131. INERTIA IN TRANSVERSE IMPACT

When a weight P strikes a beam with the velocity V , it has the kinetic energy $P \cdot V^2/2g$, and part of this is lost in the impact, while the remainder causes the beam to deflect the amount q which is greater than the deflection f due to a static load P . Let h be the height of fall which will produce the velocity V , and η be the inertia coefficient, so that ηPh is the effective work which deflects and stresses the bar. Then the formulas of Art. 129 will apply if ηh is substituted for h . The value of f will now be found for a simple beam in a manner similar to that followed

for axial impact in the last article, and under the same assumptions.

Let the weight P strike the middle of the simple beam with the velocity V ; when complete contact is obtained both P and the middle of the beam are moving with a velocity v which is less than V , and any other point of the beam is moving with a velocity u . Let W be the weight of the beam, l its length, x any distance from the left end, and δW the element which is moving with the velocity u ; then $\delta W = W \cdot \delta x/l$. When the middle point has the velocity v and the deflection y_1 , the element δW has the deflection y and the velocity $u = v \cdot y/y_1$. Then the kinetic energy stored in load and beam at the instant of complete contact is,

$$K = P \frac{v^2}{2g} + \int \delta W \frac{u^2}{2g} = \left(P + W \int \frac{y^2 \delta x}{ly_1^2} \right) \frac{v^2}{2g}$$

Now to find the value of the integral, it is assumed that the elastic curve has the same equation under a dynamic as under a static load; from Art. 55 the ordinate y of the elastic curve in terms of the abscissa x and the maximum deflection y_1 , is found to be $y = y_1(3l^2x - 4x^3)/l^3$. Then, extending the integration over the entire beam;

$$\int \frac{y^2 \delta x}{ly_1^2} = \frac{2}{l^7} \int_0^{l/2} (3l^2x - 4x^3)^2 \delta x = \frac{17}{35}$$

and accordingly the kinetic energy which is available for deflection and stress is,

$$K = \left(P + \frac{17}{35}W \right) v^2 / 2g = \left(1 + \frac{17}{35}W/P \right) P \cdot v^2 / 2g$$

To find the value of v in terms of V , the same reasoning will be followed as in the last article. Instead of $PV = (P + P_1)v$ for the impact of P against a free body P_1 at rest, there must be written for the beam,

$$PV = Pv + \int \delta W \cdot u = Pv + \frac{2Wv}{l^4} \int_0^{l/2} (3l^2x - 4x^3)^2 \delta x = \left(P + \frac{8}{5}W \right) v$$

and hence the velocity at the instant of complete contact of beam and load is $v = V / \left(1 + \frac{8}{5}W/P \right)$. Inserting this in the above expres-

sion for the effective work, there is found,

$$K = \frac{1 + \frac{1}{8} \frac{W}{P}}{(1 + \frac{1}{8} \frac{W}{P})^2} P \cdot V^2 / 2g = \eta Ph \qquad \eta = \frac{1 + \frac{1}{8} \frac{\rho}{P}}{(1 + \frac{1}{8} \frac{\rho}{P})^2}$$

in which η is the inertia coefficient and ρ is the ratio W/P .

The case of horizontal impact against a beam occurs in some testing machines, the ends of the bar being prevented from moving sidewise while a hammer strikes horizontally against the middle of the beam. Here the discussion is the same as that in Art. 129 except that h is replaced by ηh , and

$$T = S(2\eta h/f)^{\frac{1}{2}} \qquad q = (2\eta h f)^{\frac{1}{2}} \qquad (131)$$

are the formulas for dynamic flexural unit-stress and dynamic deflection. Here S is the static stress found from the flexure formula (41) and f is the static deflection found from Art. 55 for the load P , and η is the impact coefficient whose value is given above.

For the case of vertical impact where the load P falls through the height h upon the middle of the beam, the discussion is also the same as that in Art. 129, except that h is replaced by ηh , and

$$T = S + S(1 + 2\eta h/f)^{\frac{1}{2}} \qquad q = f + (f^2 + 2\eta h f)^{\frac{1}{2}} \qquad (131)'$$

are the formulas for vertical impact, in which S , f , and η have the same signification as before. All the formulas of this article are only valid when the unit-stress T is less than the elastic limit of the material.

As a numerical example, let a cast-iron simple beam of 36 inches span and 2×2 inches in section have a load of 50 pounds at the middle. The flexural unit-stress and the deflection due to this static load are found from Arts. 48 and 55 to be,

$$S = 338 \text{ pounds per square inch,} \qquad f = 0.00243 \text{ inches}$$

Now let the ends of the beam be prevented from moving sidewise when a horizontally moving load of 50 pounds strikes it at the middle with a velocity due to a fall of 2 inches. Then, disregarding the inertia of the beam, formulas (129)' give the dynamic stress and deflection,

$$T = 13700 \text{ pounds per square inch,} \qquad q = 0.0986 \text{ inches}$$

Taking the inertia of the beam into account, the weight W is 37.6 pounds, $\rho = W/P = 0.752$, $\eta = 0.632$, and then formulas (131) give,

$$T = 10\ 900 \text{ pounds per square inch,} \quad q = 0.0784 \text{ inches}$$

These values of T are greater than the elastic limit of cast iron and hence cannot be relied upon as exact. The example shows, however, that small velocities of impact may produce high dynamic stresses in a beam.

When the load P falls into a scale-pan of weight W_1 which is attached to the middle of the simple beam, the loss in impact is less than when it falls directly upon the beam. For this case the above reasoning is to be modified by replacing P by $P + W_1$ in the first value of K , and also in the second member of $PV = (P + P_1)v$. The inertia coefficient will then be given by,

$$\eta = \frac{1 + \rho_1 + \frac{1}{8}\rho}{(1 + \rho_1 + \frac{5}{8}\rho)^2} \quad \rho_1 = \frac{W_1}{P} \quad \rho = \frac{W}{P} \quad (131)''$$

For example, taking the cast-iron beam of the last paragraph, let the weight of 50 pounds fall vertically upon its middle from a height of 2 inches, there being no scale-pan; then $\eta = 0.632$ and from (131)',

$$T = 11\ 240 \text{ pounds per square inch,} \quad q = 0.0808 \text{ inches}$$

Now let there be a scale-pan weighing 20 pounds into which the load of 50 pounds falls from a height of 2 inches; here $\rho_1 = 0.400$, $\rho = 0.752$, $\eta = 0.505$, and then (131)' give,

$$T = 10\ 090 \text{ pounds per square inch,} \quad q = 0.0725 \text{ inches}$$

which show that the effect of the scale-pan is materially to diminish the dynamic stress due to impact.

The numbers $\frac{1}{8}$ and $\frac{5}{8}$ in the inertia coefficient apply only to a simple beam struck at the middle: they do not apply, however, to other points than the middle of the span. For a beam with fixed ends impinged upon at the middle, $\frac{1}{3}$ is to be used instead of $\frac{1}{8}$ and $\frac{1}{2}$ instead of $\frac{5}{8}$. For a cantilever beam struck at the end by a load, $\frac{3}{14}$ takes the place of $\frac{1}{8}$ and $\frac{3}{8}$ that of $\frac{5}{8}$.

Prob. 131*a*. Verify the statements in the preceding sentence.

Prob. 131*b*. Compute the dynamic deflection for Prob. 129*b*, taking into account the inertia of the beam.

ART. 132. VIBRATIONS AFTER IMPACT

Referring to the case of axial impact shown in Fig. 130*c*, it is clear that the velocity of the end of the bar at any instant is a function of the elongation x . When x equals the final elongation q , the velocity is zero; the end of the bar then springs back and increases until x is zero, and then decreases until it becomes zero when x is equal to $-q$; the vibration is next performed in the opposite direction. These vibrations would continue indefinitely were it not for air resistance and molecular friction, but owing to such resistances they become less and less in amplitude, until finally the bar comes to rest. Neglecting the weight of the bar in comparison with the load, the following investigation gives the time of one vibration.

Let v_x be the velocity of the end of the bar when the elongation x is attained, and let Q_x be the corresponding stress in the bar. The kinetic energy of the moving weight then equals the internal work still to be stored in the bar in increasing x to q , or $P \cdot v_x^2/2g = \frac{1}{2}Qq - \frac{1}{2}Q_x x$. Replacing Q by $P \cdot q/e$ and Q_x by $P \cdot x/e$, where e is the static elongation due to P , this equation becomes,

$$v_x^2 = (q^2 - x^2)g/e \quad \text{or} \quad (\delta x/\delta t)^2 = (q^2 - x^2)g/e$$

which gives the velocity of the end of the bar for any value of x ; this velocity is zero when $x = +q$ and also when $x = -q$. To find the time in which this vibration is performed, let t be the number of seconds counted from the instant when $x = q$; the velocity at any other instant is then $\delta x/\delta t$, as already indicated in the last equation, which may be written,

$$\frac{\delta t}{\delta x} = \left(\frac{e/g}{q^2 - x^2} \right)^{\frac{1}{2}} \quad \text{or} \quad t = \left(\frac{e}{g} \right)^{\frac{1}{2}} \arcsin \frac{x}{q}$$

and taking the integral between the limits $+q$ and $-q$ there is found $t = \pi(e/g)^{\frac{1}{2}}$ as the time of one vibration. This is the time of one vibration of a pendulum which has the length e .

This time is the same for all subsequent vibrations notwithstanding that the amplitude q becomes less and less on account of the air resistance.

For the case of the vertical bar, the first equation of this article will be modified by adding $P(q-x)$ to the first member, this expressing the work still to be performed while the load P falls through the distance $q-x$. Then are found,

$$v_x^2 = \frac{g}{e}(q^2 - x^2) - 2g(q-x) \quad t = \left(\frac{e}{g}\right)^{\frac{1}{2}} \arcsin \frac{x-e}{q-e} + C$$

the second being derived from the first by replacing v_x by $\delta x / \delta t$ and integrating as above. By discussing the first equation, it is found that v_x is a maximum when $x=e$ as indicated in Fig. 130*b*, and that v_x is zero when $x=q$. Hence, counting the time from the instant when $x=e$, the time elapsed when $x=q$ is $\frac{1}{2}\pi(e/g)^{\frac{1}{2}}$, which is that of one-half a vibration. In the backward vibration the end of the bar moves from $x=q$ to $x=e$ in the same time; the first equation shows, however, that $v=0$ when $x=-q+2e$, so that the end of the bar moves upward and the time elapsed between $x=q$ and $x=-q+2e$ is $\pi(e/g)^{\frac{1}{2}}$, which is the time of one vibration. The end of the bar hence oscillates back and forth about the point for which $x=e$, that is, about the point where it finally comes to rest; while the amplitude $q-e$ of the vibrations grows less and less, the time of each vibration remains the same, namely, that of a simple pendulum having a length e equal to the elongation due to the static load P .

The above conclusion regarding the time of vibration will be slightly modified when the inertia of the bar is taken into account. Let W be the weight of the bar and W_1 that of the scalepan at its end. Then when P and W_1 have the velocity v_x the kinetic energy of the moving particles is $(P+W_1+\frac{1}{3}W)v_x^2/2g$; for the vertical bar $P(q-x)$ is to be added to this to give the total work still to be performed. This sum is to be equated to the stress energy $\frac{1}{2}Qq - \frac{1}{2}Q_x x^2$ which is to be stored in the bar in increasing the elongation from x to q . Stating this equation, there is found,

$$v_x^2 = \frac{g}{\beta e}(q^2 - x^2) - \frac{2g}{\beta}(q-x) \quad \beta = 1 + \frac{W_1}{P} + \frac{1}{3} \frac{W}{P}$$

and by the same method as before there results,

$$t = \pi \left(\frac{\beta e}{g} \right)^{\frac{1}{2}} \quad \text{or} \quad t = \pi \left(\frac{e'}{g} \right)^{\frac{1}{2}} \quad (132)$$

as the time of one vibration, in which e' is the static elongation due to $P + W_1 + \frac{1}{3}W$. This formula also applies to the horizontal bar. As a numerical example, let the data of Problem 130 be considered. Here $P = 60$ pounds, $W = 125.7$ pounds, $W_1 = 0$, and the static elongation due to $P + \frac{1}{3}W$ is $e' = 0.000187$ inch. Then, taking g as 32.2×12 inches per second per second, the time of one vibration is $t = 0.0022$ seconds, and about 460 oscillations would be performed in one second if there were no frictional resistances.

The vibrations of a beam after the impact of a load are in all respects similar to those of a bar. By investigations exactly like those for the bar, it may be shown that the time of one vibration for a simple beam struck at the middle is,

$$t = \pi \left(\frac{\beta f}{g} \right)^{\frac{1}{2}} \quad \beta = 1 + \frac{W_1}{P} + \frac{17}{35} \frac{W}{P} \quad (132)'$$

where f is the static deflection due to P ; here βf is the static deflection due to $P + W_1 + \frac{1}{3}W$. When the load remains on the beam after impact, the vibrations occur about the position which it finally assumes under the static load; when it does not remain on the beam, the vibrations occur about the position that it had before the impact. Fig. 133 shows the vibrations of a railroad rail after impact.

The above formulas do not apply to the incomplete semi-vibration which occurs during the impact while the end of the bar is descending through the distance e or the middle of the beam through the distance f . The time of all subsequent vibrations is the same whatever be their amplitude and is equal to that of a simple pendulum which has the length βe for the bar or βf for the beam. The shorter this length the less is the time t and the more rapid are the vibrations.

Prob. 132. When a load falls upon a beam show that the amplitude of the first complete vibration is a little less than $2(f^2 + 2\eta h f)^{\frac{1}{2}}$.

ART. 133. EXPERIMENTS ON ELASTIC IMPACT

Numerous experiments have been made to test the formulas for elastic impact derived in the preceding articles, and a discussion of some of them will now be given. These formulas are not exact, because it has been supposed in their deduction that the velocity of transmission of stress is infinite, and that no loss of energy occurs except in impact. The assumption regarding velocity of stress does not lead to any appreciable error, but that regarding loss of energy may do so in cases where the falling body is deformed so that it absorbs energy or where a portion of the energy is expended in deforming the supports of the bar or beam.

Simple experiments may be made by the student, using a common spiral spring instead of a bar, so that the elongations may be easily measured. For example, a spiral spring about 32 inches long and weighing 0.6 ounces was found to elongate 0.390 inches under a static load of 10 ounces. When loaded with 8 ounces and the end depressed by the hand and then released, there were counted 304 vibrations in 100 seconds, when loaded with 14 ounces there occurred 230 vibrations in 100 seconds. Here the actual times of one vibration were 0.329 and 0.435 second, while formula (132) gives 0.321 and 0.428 seconds, so that the agreement of experience and theory is very fair.

The simplest case of impact on beams is that of a single sudden load which was discussed in Art. 127. Kirkaldy made experiments, about 1860, to test the theoretic law that the deflection under such a load is double that due to an equal static load. A load was attached to a ring placed around the middle of the beam and the ring supported so that its lower surface just touched the upper surface of the beam; the support of the ring was then suddenly withdrawn so that the load acted with its full intensity during the entire period of the deflection, which was registered upon a vertical sheet of paper by a pencil screwed to the side of the beam. Before applying the loads in this sudden manner, the deflections due to gradually

applied loads were measured. The beams were of cast iron and laid on supports 9 feet apart. The results here shown are the mean of two or three tests upon different beams. It will be found that for each size of beam the first load gives a unit-stress less than the elastic limit, while the second gives a greater value.

Size of Beam Inches	Load Pounds	Deflection in Inches		Ratio of Deflections Sudden to Gradual
		Gradual	Sudden	
1×2	112	0.253	0.515	2.04
1×2	224	0.580	0.933	1.61
1×3	224	0.163	0.303	1.86
1×3	560	0.410	0.720	1.76
4×1½	448	0.770	1.510	1.96
4×1½	784	1.275	2.225	1.73

Thus, for the first beam under 112 pounds at the middle, the unit-stress S computed from the flexure formula is 2270, while for 224 pounds it is 4540 pounds per square inch. The average of the three ratios of the deflections for the beams in which the elastic limit was not exceeded is 1.95, which is a fair agreement with the theoretic number 2.

It was early recognized that the inertia of a bar or beam diminished the theoretic stress and deflection. About 1830 the inertia coefficient η was thought to be of the form $\eta = 1/(1 + \mu \cdot W/P)$ and Hodgkinson determined by experiments on beams that the value of μ was approximately $\frac{1}{2}$, although the theoretic number $\frac{1}{3}\frac{7}{8}$ was not derived until several years later by Cox. This form of the inertia coefficient has been generally used since, and it was employed in previous editions of this book. The form deduced in this edition is believed to be more exact according to the theory of impact.

The experiments made by Keep in 1899 on tool-steel bars under both horizontal and vertical impact enable an interesting comparison of theory and practice to be made. In one series of tests bars 1×1×24 inches were loaded with weights of 25, 50, 75, and 100 pounds and the corresponding static deflections were found to be 0.0028, 0.0056, 0.0084, and 0.0112 inches. They were then struck laterally by hammers of the same weights which

swung like pendulums and had a vertical fall of 2 inches. The dynamic deflections due to these weights, as carefully measured by a graphic recording apparatus, are given below. From the given data and observed static deflections the deflections under impact have been computed from formula (131)'', and the following is a comparison of observed and computed values:

Swinging	$P=$	25	50	75	100 pounds
Observed	$q=$	0.122	0.150	0.175	0.200 inches
Computed	$q=$	0.097	0.142	0.178	0.207 inches

Experiments were also made by allowing the same weights to fall vertically on the bars through heights of 2 inches. Formula (131)' applies to this case, and the following is a comparison of the dynamic deflections as observed and computed:

Falling	$P=$	25	50	75	100 pounds
Observed	$q=$	0.130	0.159	0.181	0.209 inches
Computed	$q=$	0.100	0.150	0.186	0.219 inches

It is seen that the comparison is very satisfactory except for the lightest hammer; it would be expected, however, that the observed values should be always slightly less than the theoretic ones, because some of the work of a falling weight is probably expended in deforming and heating that weight.

Fig. 133 gives an autographic record of the deflection of a railroad rail and its subsequent vibrations, taken by P. H. Dudley in 1895. A rail 30 feet long and weighing 80 pounds per yard was placed at its extreme ends upon rigid supports and had a scale-pan weighing 210 pounds hung from the middle. Secured to the rail was an attachment carrying a pencil, which recorded the deflection and vibrations upon horizontally moving paper. A load of 100 pounds being suddenly applied, the dynamic deflection was 0.24 inches, but when the beam came to rest the static deflection was 0.12 inches. The weight of 100 pounds was then dropped upon the scale-pan from a height of 12 inches, and the maximum deflection was 0.91 inches; about 240 vibrations then ensued and in about 42 seconds the rail came to rest. Applying formula (131)' and (131)'' to this case, there are found $\rho=8$, $\rho_1=2.1$, $\eta=0.1067$, and

$q=0.69$ inches for the dynamic deflection, which is not a good agreement with the observed value. Applying formula (132) there

results $t=0.146$ for the time of one vibration, and hence the theoretic time for 240 vibrations is about 35 seconds. While the numerical results derived from theory do not agree very well with the observations, this experiment is a very instructive one, and the figure shows how a beam vibrates back and forth about the position that it occupies after coming to rest.

Prob. 133. Explain all the lines and notes on the left-hand part of Fig. 133. See Railroad Gazette, May 31, 1905.

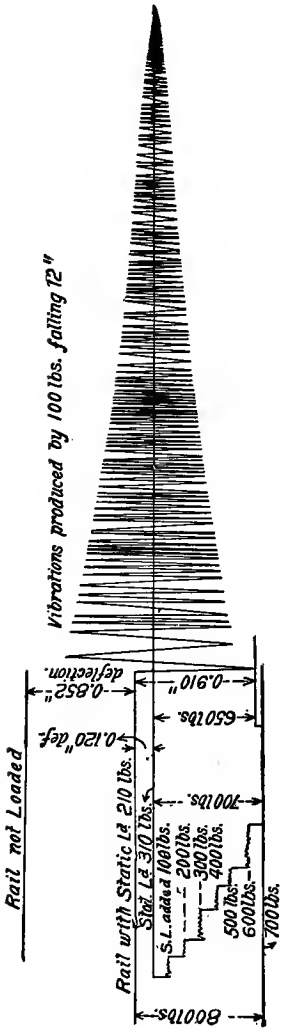

Fig. 133

ART. 134. PRESSURE DURING IMPACT

When a weight P falls from a height h upon the end of a vertical bar, a pressure is produced which is equal at any instant to the stress then existing in the bar. For the case of elastic elongation discussed in Art. 130, the maximum stress is Q , which occurs when the greatest elongation q is attained. The stress Q_x which occurs for any elongation x is equal to $P \cdot x/e$, where e is the static elongation due to P . Thus the pressure increases directly with x , becomes P when $x=e$, and reaches its maximum value Q when the greatest elongation

q is reached. Similarly, Art. 131 shows that for a beam under elastic impact, the pressure on the beam increases directly as the deflection y , becomes equal to P when $y=f$, and reaches its maximum value when the maximum deflection q is attained.

The actual forces acting between the falling load and the end of the bar differ somewhat from the stress in the bar, because there exists a pressure which overcomes inertia during the first part of the fall. The exact determination of the actual pressure for the case of elastic impact is a problem of so much complexity that it will not be undertaken here, while its determination is impossible by theory for cases where the elastic limit of the material is exceeded. From the point of view of the engineer, the pressures that cause motion of the bar or beam are of little importance compared with those that cause deformation of the material.

The following method is sometimes used for estimating the mean pressure on a beam during its deflection under impact. Let R be this mean or average pressure which is exerted through the deflection q . Then Rq is the work performed by it, while that done by the falling load is $P(h+q)$. Placing these equal there results $R=P(1+h/q)$ for the mean pressure. While this expression is correct for both elastic and non-elastic deflections, it must be borne in mind that it does not give the mean compressive stress on the upper surface of the beam where the impact occurs, but always a greater value, because some of the pressure is exerted in overcoming inertia.

To illustrate, take the case of the railroad rail discussed at the end of the last article, where a weight of 100 pounds fell from a height of 12 inches and caused an elastic deflection of 0.91 inches. Then $R=100 \times 12.91 / 0.91 = 1420$ pounds for the average pressure during the dynamic deflection. The static load Q which will produce the same deflection is $Q=100 \times 0.91 / 0.12 = 760$ pounds, so that the average pressure which was effective in stressing the beam and causing the deflection was 380 pounds. Undoubtedly, the actual average pressure was about 1420 pounds, but more than two-thirds of this was expended in overcoming the inertia of the heavy beam.

In all cases of elastic impact, the mean or average stress is one-half of the maximum; because the stress increases uniformly with the deflection. This is not true when the elastic limit of

the material is exceeded, and in general the mean stress is less than one-half of the maximum. The same probably holds for the total pressure that is exerted both to overcome inertia and to cause stress. The maximum unit-pressure that acts between the surfaces of contact will depend, of course, upon the area of contact and upon the manner in which the total pressure is distributed over that area.

Prob. 134*a*. A vertical bar weighing 27 pounds receives a stress of 196 pounds when a load of 100 pounds acts axially upon it. Through what height must a load of 50 pounds drop in order to produce the same stress?

Prob. 134*b*. A ram weighing 2 000 pounds falls from a height of 20 feet upon a railroad rail laid on supports 6 feet apart, this being one method of testing rails at the mill. Compute the average pressure when the ram deflects a heavy rail $2\frac{1}{2}$ inches; also when it deflects a lighter rail 5 inches.

ART. 135. IMPACT CAUSING RUPTURE

The cases of impact thus far considered have been those where the greatest unit-stress does not exceed the elastic limit of the material. It is, however, easy to cause the rupture of a bar or beam by allowing a heavy load to drop upon it from a sufficient height. For such cases theory furnishes no formulas and experiment is the only source of information. Many tests have been made to ascertain the phenomena of rupture under impact, and the general conclusions derived will now be stated.

In 1807 Thomas Young announced the fundamental ideas of the resistance of materials under impact. "The action which resists pressure," he said, "is called strength, and that which resists impulse may properly be called resilience." He stated that the resilience of a body is proportional to its strength and extension jointly, and that it is measured by the height through which a given weight must fall to cause rupture. The resilience of beams of the same kind he made proportional to their volumes, as also the resilience of shafts, whether solid or hollow.

At that time the elastic limit of materials was only vaguely recognized, and Hooke's law of proportionality of deformation to stress was often applied to all the phenomena preceding rupture. Young's statements are valid in a general way, but it is now known that there are two divisions of the subject of impact: first, that where the elastic limit is not exceeded and where the term resilience is properly applicable, and second, that where the elastic limit is exceeded and rupture finally occurs.

In 1818 experiments were made by Tredgold on wooden beams subject to the impact of a falling ball, and he concluded that the work required to produce rupture was not proportional to the volume of the bar. Hodgkinson in 1835 experimented on cast-iron beams and found that the deflections seemed to be proportional to the velocities of the falling weight. In 1849 were published the results of an extensive series of experiments made by a British commission, and here the influence of inertia in diminishing the deflection of a beam under impact was fully recognized. Kirkaldy in 1862 made experiments on axial impact by sudden loads, and found that some bars were broken under loads less than those required when slowly applied. The impact hammer or ram, introduced by Sandberg and Styffe in 1868 for testing railroad rails, has proved valuable for comparative purposes since the information obtained is similar to that derived from the cold-bend test. Maitland, in 1887, showed by many experiments on tensile specimens subject to many blows of a falling ram, that the ultimate elongation was much greater than in static tests; the use of many blows to cause rupture introduces, however, complications, and it has been found that the best plan to obtain valid results is to use a load and fall which is just sufficient to break the specimen at one blow.

When a specimen is broken under tensile impact, the work expended may be ascertained by measuring the area of a stress diagram which is autographically drawn by the machines and which also shows the ultimate elongation. Experiments of this kind made by Hatt in 1904 on various kinds of steel have shown that the work required to rupture a bar by impact is usually

greater than that in common static tests where the load is gradually applied. From the mean of about 170 tests, Hatt found that the average work required for rupture by impact was 30 percent greater than in static tests, and that the ultimate elongation under rupture was 20 percent greater. The fracture was similar in both impact and static tests, but in the former there were often observed two or more places of marked diminished section, whereas only one occurred in the latter. For round bars of soft steel there appeared to be little difference in ultimate elongation and work whether the bars were broken in ten minutes by the common method or in one one-hundredth of a second by impact.

When a body is ruptured by impact, it is important that the apparatus should be so arranged that all the work of the falling ram may be expended on the specimen, and not be absorbed by other parts of the apparatus. If the weight falls upon a shelf or pan connected to the bar or beam, this should be made heavy so that work may not be expended in deforming it. When the ends of a tensile specimen are larger than the main part, they should be made very large so as not to absorb energy, and the supports of a beam should be made heavy for a similar reason. Impact tests are of much value in determining the quality of materials, and they are widely used for railroad rails, car and locomotive axles, and other steel pieces which are subject to shocks. The impact tests introduced by Keep for cast iron undoubtedly give valuable information regarding its behavior under shocks. In general it is probable that impact tests show lack of homogeneity of the material better than static tests.

Autographic records taken during a tensile impact test give valuable information regarding the elastic limit and ultimate strength of the material. The elastic limit is often found to be higher than under static tests, while the ultimate strength is usually a little lower, the difference between these unit-stresses being much less than in the usual method of testing. For timber Hatt has found that the elastic limit is nearly doubled under impact.

The formulas for dynamic stress and elongation deduced in the preceding articles do not apply to cases where the elastic limit is exceeded, and hence all attempts to verify these formulas by experiments on the rupture of bars and beams are fallacious. Hodgkinson broke cast-iron beams under both sudden and gradual loads, and found that the ratio of the latter to the former was always less than 2, which should be the true ratio if the elastic law were applicable. The following, for example, are three of his results for cast-iron beams with a span of 9 feet:

Size of Beam Inches	Breaking Load in Pounds		Ratio of Gradual to Sudden Load
	Gradual	Sudden	
1 × 2	1 000	569	1.76
1 × 3	2 008	1 219	1.65
4 × 1½	1 911	1 082	1.77

The discrepancy between the theoretic ratio and the actual ones is here not very great because the elongation for cast-iron is small (Fig. 4). For wrought iron, where the elongation is large and the stress curve greatly deviates from a straight line, a greater discrepancy would be expected, and Kirkaldy found that the ratio of gradual to sudden load which caused the rupture of wrought-iron beams ranged from 1.2 to 1.3.

Prob. 135. Consult Hatt's paper in Proceedings of the American Society for Testing Materials, Vol. IV, 1904, and describe the machine used for making tensile impact tests.

ART. 136. STRESSES DUE TO LIVE LOADS

A beam or bridge is subject to the action of both dead and live loads, the former including its own weight and the latter the weight of the people, vehicles, or trains that pass over it. The flexural stresses in the beam are found by the application of formula (41) and those in the members of a bridge truss by the methods set forth in Roofs and Bridges, Part I. These stresses are usually computed for dead and live loads separately, regarding each as a static load. The live load, however, really produces greater stresses than the computed ones because it is applied

quickly, and hence it is customary to multiply the computed static stresses by a number called the "coefficient of impact" in order to obtain the increased stress due to suddenness of application. Thus, let S be any computed stress due to the given live load, this being either a unit-stress or the total stress in a member; then ιS is the stress due to the quickness with which the load is applied, and ι is the coefficient of impact, so that the total stress due to the live load is $S + \iota S$ or $(1 + \iota)S$. This use of the word impact does not agree with that of the preceding articles, but it is customary in bridge literature; really this coefficient of impact includes the effect of lateral and vertical oscillations due to irregularities of the track as well as the effect of quickness of application of the live load.

Various methods are in use for assigning values of the coefficient α , but in all of them no attention is paid to the time in which the stress is generated, and in fact they rest upon no theoretical basis except the law that a suddenly applied load produces double the stress of a static one. Some engineers regard ι as unity for all cases of live load, and hence double the stress due to the live load in designing the section areas of the members. Many others take ι as less than unity, using higher values for light bridges than for heavy ones, while some make ι depend upon the length of span and take it higher for short spans than for long ones. Empirical formulas for ι are given in *Roofs and Bridges*, Part I (New York, 1905).

In this important matter experience is in advance of theory since no formula has yet been established for the case of a load P applied to a bar in a given time. When slowly applied P produces a unit-stress S , when suddenly applied it produces a unit-stress $2S$, if the elastic limit is not exceeded (Art. 127); when applied in a given time t , the unit-stress should lie between S and $2S$. Hence there must exist a certain function $\phi(t)$ so that the dynamic unit-stress is given by $T = \phi(t)S$; when t is large, T must equal S ; when t is zero, T will be $2S$. Many empirical expressions can be derived which satisfy these limiting conditions, but the determination of the theoretic form of $\phi(t)$ is greatly

to be desired, because a knowledge of it would be of much practical benefit in promoting the correct design of members of bridge trusses.

The discussion published in Zimmermann, in 1896, regarding the increase in stress and deflection due to the velocity of a live load when crossing a simple beam, is probably the nearest approach to the solution of this important problem, but the formulas deduced are too complicated to be given here. Let v be the velocity of a single load P which rolls over the beam of span l and depth d , and let f be the static deflection due to P . When v is zero, the dynamic unit-stress is S ; as v increases the dynamic unit-stress increases, but it can never become as great as $2S$; when v^2 has the value $gl^2/8f$, where g is the acceleration of gravity, the load P reaches the middle of the span in the same time that gravity causes a body to fall freely through the distance f , then also $T=S$; when v has a greater value, then T is less than S ; when $v^2 = gr$, where r is the radius of the earth, then $T=0$. The important cases hence occur when v is less than $(gl^2/8f)^{\frac{1}{2}}$. From Zimmermann's investigation, there may be written,

$$T = S(1 - 2\beta)/(1 - 3\beta) \quad \beta = 8Sv^2/3Edg$$

which applies only when β is less than 0.1, but this covers most cases of usual speeds of live loads on beams. For example, take a stringer in a bridge floor which is 2 feet deep; the ratio S/E is about 4 000, and hence $\beta = 0.082$ for a velocity of 60 miles per hour or 88 feet per second; then $T = 1.11$ so that the dynamic stress is 11 percent greater than the static stress.

While the above theoretic formula gives much lower values of T than those used in bridge practice, it may be noted that it refers only to the middle of the span of the beam, and that for other points the theoretic percentage of increase may be much greater. For the quarter points of a short span under speeds varying from 80 to 100 miles per hour, the investigations of Zimmerman indicate that the percentage may be as high as 65 percent. The empirical percentages used in bridge practice range from 100 to 50 percent, so that it is plain that these

are not too large, particularly when it is considered that they include the effect of the shocks due to the hammer of wheels which are not properly balanced.

Prob. 136*a*. Deduce the condition that the load P shall reach the middle of the span in the same time that a body falls freely by gravity through the deflection f .

Prob. 136*b*. Consult Zimmermann's *Schwingungen eines Trägers mit bewegter Last* (Leipzig, 1896), and show that the above formula agrees with the one given by him on page 39.

ART. 137. FATIGUE OF MATERIALS

The ultimate strength S_u is usually understood to be that steady unit-stress which causes rupture of a bar at one application. Experience and experiments, however, teach that rupture may be caused by a unit-stress somewhat less than S_u when it is applied a sufficient number of times to a bar. The experiments made by Wöhler from 1859 to 1870 were the first that indicated the laws which govern the rupture of metals under repeated applications of stress. For instance, he found that the rupture of a bar of wrought iron by tension was caused in the following different ways:

- by 800 applications of 52 800 pounds per square inch
- by 107 000 applications of 48 400 pounds per square inch
- by 450 000 applications of 39 000 pounds per square inch
- by 10 140 000 applications of 35 000 pounds per square inch

The range of stress in each of these applications was from 0 to the designated number of pounds per square inch. Here it is seen that the breaking unit-stress decreases as the number of applications increase. In other experiments where the initial stress was not 0, but a permanent value S , the same law was seen to hold good. It was further observed that a bar could be strained from 0 up to a stress near its elastic limit an enormous number of times without rupture, and it was also found that a bar could be ruptured by a stress less than its elastic limit under a large number of repetitions of stress which alternated from tension to compression and back again.

Wöhler's experiments were made on repeated tensile stresses, repeated flexural stresses, and on flexural stresses alternating from tension to compression, these being produced by a machine which brought repeated loads upon the specimen for long periods of time, as high as forty millions of repetitions being made in some cases. Similar experiments were later made by Bauschinger and others on steel, and from the recorded results the following laws may be stated:

1. The rupture of a bar may be caused by repeated applications of a unit-stress less than the ultimate strength of the material.

2. The greater the range of stress, the less is the unit-stress required to produce rupture after an enormous number of applications.

3. When the unit-stress in a bar varies from 0 up to the elastic limit, an enormous number of applications is required to cause rupture.

4. A range of stress from tension into compression and back again, produces rupture with a less number of applications than the same range in stress of one kind only.

5. When the range of stress in tension is equal to that in compression, the unit-stress that produces rupture after an enormous number of applications is a little greater than one-half the elastic limit.

The term 'enormous number' means about 40 millions, that being roughly the number used by Wöhler to cause rupture under the conditions stated. For all cases of repeated stress in bridges, this great number will not be exceeded during the natural life of the structure; for locomotive axles and moving parts of machines, however, a larger number of repetitions of stress may occur.

The word 'fatigue' means the loss of molecular strength under stresses often repeated. When a bar is stressed above the elastic limit its temperature increases due to internal molecular friction (Art. 147) and it is known that the elastic properties of the material are injured. Hence in a general way it is easy to explain why fatigue occurs under repeated stresses that exceed

the elastic limit. An examination of fractures of bars after an enormous number of repetitions shows certain small surfaces where sliding or shearing has occurred; these are called 'micro-flaws,' although they can often be seen without the use of a microscope. In iron and steel these flaws begin along the surfaces of the ferrite crystals and later are extended to cause cracks along the cleavage planes of the crystals.

When the elastic limit is not exceeded it is not so easy to understand why fatigue should occur under repeated stresses. However, physical and thermodynamic discussions have proved that small changes in temperature occur when a bar of metal is stressed within the elastic limit, it becoming cooler under tension and warmer under compression. The measurements of these changes made by Turner, in 1902, have shown that these changes in temperatures continue at a uniform rate up to about three-fifths of the elastic limit, and that then a marked change occurs, the bar under tension then beginning to grow warmer while the temperature of the bar under compression increases at a more rapid rate. It thus appears that for stresses higher than about three-fifths of the elastic limit, at least, energy is converted into heat under repeated applications; probably this occurs also at lower stresses when repeated stresses range from tension into compression in a bar, or when a beam is subject to alternating flexure. The valuable experiments of Turner hence throw light upon the reason why fatigue occurs under alternating stresses, and it is likely that further investigations in this direction may lead to other important conclusions. The discussions in Arts. 146-147 indicate that internal friction occurs under stresses that do not exceed the elastic limit, and this point of view is also one which will assist future investigations.

In Art. 7 it was recognized that allowable unit-stresses should be less for bars subject to varying loads than for those carrying steady loads only. It has indeed long been the practice of designers to grade the allowable working stresses for bars according to the range of stress to which they might be liable to be subjected. The above laws of fatigue furnish a method of doing

this which has been used by some engineers, and formulas for that purpose will be deduced in the next article.

Prob. 137*a*. How many years will probably be required for a locomotive axle to receive forty million repetitions of flexural stresses?

Prob. 137*b*. Consult Turner's paper in Transactions American Society of Civil Engineers, 1902, Vol. 48, and examine the thermal stress curves derived from his experiments.

ART. 138. STRENGTH UNDER FATIGUE.

Consider a bar in which the unit-stress-varies from S' to S , the latter being the greater numerically. Both S' and S may be tension or both may be compression, or one may be tension and the other compression; in the last case the sign of S' is to be taken as minus. Consider the stress to be repeated an enormous number of times from S' to S , and rupture to then occur under the greater unit-stress S , which may be called the strength of the material under fatigue. By the second law above stated S is some function of $S - S'$; this is equivalent to saying that S is a function of $S(1 - S'/S)$, or more simply a function of S'/S . Now if P' and P be the total stresses on the bar, the ratio S'/S equals P'/P , and hence the unit-stress S which causes rupture after an enormous number of repetitions is a function of P'/P .

A formula for S when the limiting stresses P' and P are both tension or both compression, so that P'/P is always positive, was deduced by Launhardt in 1873. Let the values of this ratio be taken as abscissas ranging from 0 to 1, while those of S are ordinates, as in Fig. 138*a*. Let the function of P'/P be supposed to represent a straight line which has the equation $S = C_1 + C_2(P'/P)$ in which C_1 and C_2 are constants to be determined. Let S_u be the ultimate strength of the material and S_e the elastic limit. Now if P'/P is unity, then S is S_u and hence $C_1 + C_2 = S_u$; also, from the third law of the last article, S is S_e when P'/P is zero. These two conditions give $C_1 = S_e$ and $C_2 = S_u - S_e$, and the equation of the straight line becomes,

$$S = S_e + (S_u - S_e)P'/P \quad \text{or} \quad S = S_e \left(1 + \frac{S_u - S_e}{S_e} P'/P \right)$$

which is Launhardt's formula for the unit-stress S that ruptures the bar after an enormous number of repetitions of a load that ranges from P' to P . For structural steel, using the mean values of S_u and S_e in Tables 2 and 3, this becomes $S = 35\,000(1 + \frac{1}{4}P'/P)$; for wrought iron it becomes $S = 25\,000(1 + P'/P)$. For example, let a bar of structural steel range in tension from 80 000 to 160 000 pounds; then P'/P is 0.5, and $S = 47\,500$ pounds per square inch is the unit-stress that will cause rupture after an enormous number of repetitions.

A formula for S when the bar ranges in stress from P' to P , one being tension and the other compression, and P being the greater numerically, was deduced by Weyrauch in 1877. Here P'/P is always negative, and the law connecting it with S is again assumed to be $S = C_1 + C_2(P'/P)$; Fig. 138*b* represents this case. Let S_e be the unit-stress at the elastic limit and S_a the unit-stress which, under the fifth law of the last article, causes rupture when the load alternates from a certain value in tension to the same value in compression. By the third law, if P'/P is zero, then S is S_e and hence $C_1 = S_e$. By the fifth law, if P'/P is -1 , then S is S_a and hence $C_2 = S_e - S_a$. The equation of the straight line therefore becomes,

$$S = S_e + (S_e - S_a)P'/P \quad \text{or} \quad S = S_e \left(1 + \frac{S_e - S_a}{S_e} P'/P \right)$$

which is Weyrauch's formula for the unit-stress which ruptures a bar after an enormous number of repetitions of a load alternating from tension to compression and back again. S_a is usually taken as $\frac{1}{2}S_e$ in the absence of knowledge regarding its exact value. For structural steel the formula becomes $S = 35\,000(1 + \frac{1}{2}P'/P)$, in which P'/P is always negative. Thus, if P' is 80 000 pounds compression and P is 160 000 pounds tension, then $P'/P = -0.5$, and $S = 26\,200$ pounds per square inch is the unit-stress that will cause rupture.

Another formula, deduced by the author in 1884, gives values of S for both positive and negative values of P'/P , and thus includes the two cases discussed above. The law of variation of S is assumed to be represented by a curve joining the tops of

the three ordinates S_u , S_e , S_a , in Fig. 138c. The simplest curve is a parabola given by the equation $S = C_1 + C_2(P'/P) + C_3(P'/P)^2$. To determine the three constants, consider, first that S becomes S_u when $P'/P = +1$, and hence $C_1 + C_2 + C_3 = S_u$; secondly, that S becomes S_e when $P'/P = 0$, and hence $C_1 = S_e$; thirdly, that S becomes S_a when $P'/P = -1$, and hence $C_1 - C_2 + C_3 = S_a$. From these conditions, the values of C_1 , C_2 , C_3 are found and the equation of the parabola becomes,

$$S = S_e + \frac{1}{2}(S_u - S_a) \frac{P'}{P} + \frac{1}{2}(S_u + S_a - 2S_e) \left(\frac{P'}{P}\right)^2 \quad (138)$$

which is a formula for the rupturing unit-stress S when the total stress ranges an enormous number of times from P' to P . When P' and P are both tension or both compression, the ratio P'/P is positive; when one is tension and the other compression, P'/P is negative. It is seen that (138) gives values of S a little smaller than those found from the straight-line formulas.

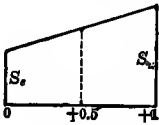

Fig. 138a

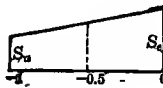

Fig. 138b

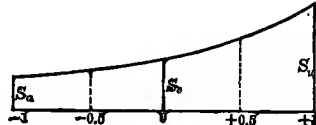

Fig. 138c

For structural steel, where $S_u = 60\,000$, $S_e = 35\,000$, and $S_a = 17\,500$ pounds per square inch, the formula (138) reduces to,

$$S = 35\,000[1 + 0.61(P'/P) + 0.11(P'/P)^2]$$

For a bar of such steel in which the stress ranges from 180 000 pounds tension under dead load to 540 000 pounds tension under live load, the value of P'/P is $+\frac{1}{3}$, and the formula gives $S = 42\,500$ pounds per square inch. If the stress ranges from 180 000 pounds compression to 540 000 pounds tension, then P'/P is $-\frac{1}{3}$, and $S = 28\,300$ pounds per square inch.

When the above formulas are used for designing, a factor of safety is applied, the computed values of S being divided by this factor, and thus the allowable unit-stress is obtained. About 1880 the formulas of Launhardt and Weyrauch were

extensively used in determining the allowable unit-stresses for designing members of bridge trusses, but their use has gradually been replaced in the United States of America by other methods. Since no unit-stress used for a bridge member can be allowed to be greater than about one-half of the elastic limit of the material, it is claimed by many engineers that the ideas of fatigue cannot enter in making the design. Nevertheless this question must not be ignored, especially for locomotive-axles and tires and for parts of machines subject to shocks. Tests of materials under repeated stresses, or endurance tests as they are sometimes called, are still in progress at the Watertown Arsenal, at the testing laboratory of the Pennsylvania Railroad, and in other places; when sufficient records have been accumulated they will prove of great value in further investigations into this subject.

Prob. 138*a*. A short bar of wrought iron is subject to repeated stresses ranging from 16 000 pounds compression to 80 000 pounds tension. What should be the area of its cross-section for a factor of safety of 5?

Prob. 138*b*. Consult Tests of Metals, published annually by the ordnance office of the U. S. Army, and describe some of the endurance tests on rotating shafts made by Howard.

CHAPTER XV

TRUE INTERNAL STRESSES

ART. 139. PRINCIPLES AND LAWS

In Art. 13 it was explained that a bar under tension suffers a contraction in its section area, each lateral dimension having a unit-contraction proportional to the longitudinal unit-elongations, when the elastic limit of the material is not exceeded. Let S be the tensile unit-stress, ϵ the unit-elongation, λ the factor of lateral contraction, and E the modulus of elasticity of the material; the lateral unit-shortening is then $\lambda\epsilon$. Since $S = \epsilon E$ is the relation between S and ϵ (Art. 9), it may be considered that the lateral unit-shortening $\lambda\epsilon$ corresponds to a unit-stress T which has such a value that $T = \lambda\epsilon E$, where T is a compressive unit-stress which would produce the unit-shortening $\lambda\epsilon$ in the absence of any axial stress. Thus, $T = \lambda S$ is called a true internal stress which acts as a compression at right angles to the axis of the bar.

The mean value of λ for wrought iron and steel is about $\frac{1}{3}$. Accordingly, a steel bar under the tensile unit-stress S suffers a true internal compressive unit-stress of $\frac{1}{3}S$ in all directions at right angles to its length; similarly, a steel bar under the compressive unit-stress S suffers a true internal tensile unit-stress of $\frac{1}{3}S$ in all directions at right angles to its length. For instance, let a steel bar 2×3 inches in section and 10 inches long be subject to a tension of 90 000 pounds; the axial tensile unit-stress S is 15 000 pounds per square inch and the lateral internal compressive unit-stress is 5 000 pounds per square inch. The same lateral deformation of the bar, when no axial load is acting, might be produced by two compressive loads acting at right angles to each other, one uniformly distributed over the side of 20 square inches area and the other over the side of 30 square inches area; it may be shown from the following discussion that these two compressive loads are 150 000 and 225 000 pounds.

When applied tensile forces act upon a body in three directions, each force being at right angles to the plane of the other two, there is an elongation due to each force in its own direction and a shortening in directions normal to it. It is a reasonable assumption that each force produces its deformations independently of the other two, and this is also justified by experience and experiment. The true stress in any direction depends upon the actual deformation in its direction. The letter S will denote the apparent unit-stress as computed by the methods of the preceding chapters, while T will denote the true unit-stress corresponding to the actual deformation. The injury done to a body does not depend upon the actual stress or pressure but upon the actual deformations produced, and the true stresses are those corresponding to these deformations.

Let a homogeneous parallelepiped be subject to tensile forces acting normally upon its six faces, those upon opposite faces being

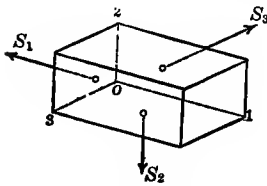

FIG. 139

equal. Let the edges of the parallelepiped be designated by o_1 , o_2 , o_3 , as in Fig. 139. Let S_1 be the normal unit-stress upon the two faces perpendicular to the edge o_1 , and S_2 and S_3 those upon the faces normal to o_2 and o_3 ; thus the directions of S_1 , S_2 , S_3 are parallel to o_1 , o_2 , o_3 , respectively. Then, supposing that the modulus of elasticity E and the factor of lateral contraction λ are the same in all directions, the true unit-elongations ϵ_1 , ϵ_2 , ϵ_3 in the three directions are found from the expressions,

$$E\epsilon_1 = S_1 - \lambda S_2 - \lambda S_3 \quad E\epsilon_2 = S_2 - \lambda S_3 - \lambda S_1 \quad E\epsilon_3 = S_3 - \lambda S_1 - \lambda S_2$$

Now $E\epsilon_1$ may be designated by T_1 , this being the unit-stress which would produce the elongation ϵ_1 in the direction o_1 if S_2 and S_3 were not acting; also the unit-stresses $E\epsilon_2$ and $E\epsilon_3$ may be designated by T_2 and T_3 . Hence it follows that

$$T_1 = S_1 - \lambda S_2 - \lambda S_3 \quad T_2 = S_2 - \lambda S_3 - \lambda S_1 \quad T_3 = S_3 - \lambda S_1 - \lambda S_2 \quad (139)$$

are the true stresses acting in the three rectangular directions. If any stress S is compression, it is to be taken as negative in the

formulas, and then the true stresses are tensile or compressive according as their numerical values are positive or negative.

For example, let a cube be stressed upon all sides by the apparent unit-stresses S ; then the true internal unit-stress T is $S(1-2\lambda)$; for steel $\lambda = \frac{1}{3}$, and $T = \frac{1}{3}S$, and thus the linear deformation is only one-third of that due to a unit-stress S applied upon two opposite faces. Again, if a bar has a tension S_1 in the direction of its length, and no stresses upon its sides, then $T_1 = S_1$, while $T_2 = T_3 = -\lambda S_1$.

As a simple example, let a steel bar 2 feet long and 3×2 inches in section area be subject to a tension of 60 000 pounds in the direction of its length and to a compression of 432 000 pounds upon the two opposite flat sides. Here $S_1 = 60\,000/6 = 10\,000$ pounds per square inch, $S_2 = -432\,000/72 = -6\,000$ pounds per square inch, and $S_3 = 0$. Then from (139), taking λ as $\frac{1}{3}$, the true internal stresses are $T_1 = +12\,000$, $T_2 = -9\,330$, $T_3 = -1\,330$ pounds per square inch, and it is thus seen that the true tensile unit-stress is 20 percent greater than the apparent, while the true compressive unit-stress is more than 50 percent greater than the apparent.

The term 'apparent stresses' will be used to indicate the stresses computed by the methods of the previous chapters where no lateral deformation has been taken into account. In Chapter XI such stresses have been combined in order to obtain the resultant maximum tension, compression, and shear, but it will now be shown that the true internal stresses corresponding to the actual deformations of the material are often much greater than the apparent ones. It is very important to consider these true stresses in many problems of investigation and design which occur in engineering practice.

Prob. 139. A common brick, $2\frac{1}{2} \times 4 \times 8\frac{1}{4}$ inches in size, is subject to a compression of 3 200 pounds upon its top and bottom faces, 500 pounds upon its sides, and 60 pounds upon its ends. Taking λ as 0.2, compute the true internal stresses in the three directions.

ART. 140. SHEAR DUE TO NORMAL STRESS

The term 'normal stress' is used for the tension or compression that acts normally to a plane in the interior of a body. The rectangular bar in Fig. 140*a* may be said to be acted upon by normal loads, and planes perpendicular to these loads are said to be subject to normal unit-stress. Other normal stresses also act upon other planes within the bar, but it will be shown that the normal unit-stresses upon such planes are less than upon planes perpendicular to the directions of P_1 and P_2 . Let S_1 be the normal unit-stress on a plane perpendicular to P_1 , and S_2 that on a plane perpendicular to P_2 ; then the true unit-stresses T_1 and T_2 , as also the true unit-stress T_3 at right angles to these, are readily found by the methods of Art. 139. There also exist shearing stresses in the bar which will now be considered. Let any plane be drawn cutting it obliquely and let the given forces be resolved into components parallel to this plane; the sum of these components forms a shear acting along the plane, and the intensity of the shear will vary with the inclination of the plane. It is required to find the maximum shearing unit-stresses.

Let l be the length, b be the breadth, and d the depth of the rectangular bar in Fig. 140*a*, subject to the two normal forces P_1 and P_2 , while there is no force acting upon the side whose area is ld . The normal unit-stresses then are $S_1 = P_1/bd$, $S_2 = P_2/bl$, $S_3 = 0$. Let Fig. 140*b* represent any elementary parallelepiped in the interior of the bar, having the length δx , depth δy , and width unity; then $S_1\delta y$ is the normal stress upon its ends, and $S_2\delta x$ is the normal stress upon the upper and lower sides. Let θ be the angle which the diagonal δz makes with δx , and let S' be the shearing unit-stress that acts along the diagonal. The total shearing stress along the diagonal then is $S'\delta z$ and this is equal to the algebraic sum of the components of the normal stresses in that direction. Accordingly, noting that $\delta y/\delta z = \sin\theta$ and $\delta x/\delta z = \cos\theta$, there result,

$$S'\delta z = S_1\delta y \cdot \cos\theta - S_2\delta x \sin\theta \quad \text{or} \quad S' = (S_1 - S_2)\sin\theta \cos\theta$$

and the second equation gives the shearing unit-stress along

any plane which makes the angle θ with the direction of S_1 . The maximum value of S' occurs for $\theta = +45^\circ$ or $\theta = -45^\circ$, and for both cases may be written $S' = \pm \frac{1}{2}(S_1 - S_2)$, that is, the maximum shearing unit-stress occurs on two planes which bisect the directions of S_1 and S_2 , and its numerical value is equal to one-half of their difference. The broken lines in Fig. 140a show these two sets of planes.

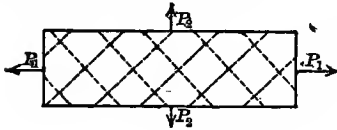

Fig. 140a

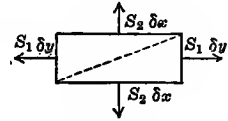
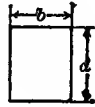

Fig. 140b

The same conclusion follows when true stresses are considered. If T_1 and T_2 are the true unit-stresses due to the apparent unit-stresses S_1 and S_2 , then the true maximum shearing unit-stresses are equal to one-half their difference, and they act in planes which bisect the directions of T_1 and T_2 . Accordingly, the formulas,

$$S' = \frac{1}{2}(S_1 - S_2) \quad \text{and} \quad T' = \frac{1}{2}(T_1 - T_2) \quad (140)$$

give the maximum internal shearing unit-stresses. These may be either positive or negative, but it is best to consider internal shear as a signless quantity, since it acts in opposite directions on opposite sides of the plane.

As a numerical example, take a cast-iron bar for which the factor of lateral contraction λ is $\frac{1}{4}$; let it be one square inch in section area and be subject only to an axial tension of 2 400 pounds. Then $S_1 = +2\,400$ and $S_2 = 0$, whence the maximum apparent shearing unit-stress is $S' = 1\,200$ pounds per square inch. From (139) the true axial unit-stress is $T_1 = +2\,400$ and the true lateral unit-stress is $T_2 = -600$ pounds per square inch. Accordingly the maximum true shearing unit-stress is $T' = 1\,500$ pounds per square inch, which is 25 percent greater than the apparent. It is indeed very common to find that the true stresses based on the actual deformations are much larger than the stresses computed from the common theory, and this is one reason for the use of high factors of safety.

The above discussion applies equally well when one or both of the applied loads is compression. For example, let the axial unit-stress S_1 be tension and the lateral unit-stress S_2 be compression, each equal to 2 400 pounds per square inch. Then the apparent maximum shearing unit-stress is $S' = \frac{1}{2}(2\ 400 + 2\ 400) = 2\ 400$ pounds per square inch. For $\lambda = \frac{1}{3}$, the true axial stress is $T_1 = +3\ 200$ and the true lateral stress is $T_2 = -3\ 200$, so that the true maximum shearing unit-stress is $T' = 3\ 200$ pounds per square inch, which is 33 percent higher than S' .

When S_1 and S_2 are equal numerically, both being tension or both compression, then $S' = 0$, and also $T' = 0$; that is, a parallelepiped under uniform stress in two rectangular directions has no internal shearing stress. The same is true when a body is acted upon by equal tensions or pressures in three rectangular directions, for the third stress S_3 exerts an equal influence upon the two normal to it.

When there are three unit-stresses S_1, S_2, S_3 , acting upon a parallelepiped in three rectangular directions, the shearing unit-stress on a plane parallel to S_1 and S_2 is not influenced by S_3 , and hence $\frac{1}{2}(S_1 - S_2)$ is the maximum shearing unit-stress for such a plane. Similarly, $\frac{1}{2}(S_1 - S_3)$ and $\frac{1}{2}(S_2 - S_3)$ are the maximum shearing unit-stresses for planes parallel to S_1 and S_2 and to S_2 and S_3 respectively. The same holds true for the true stresses T_1, T_2, T_3 ; an algebraic discussion of this case will be found in Art. 178. As an example, let a rectangular bar be subject to an axial tension of 3 000 pounds per square inch, and to a compression of 6 000 pounds per square inch upon two opposite sides. Here $S_1 = +3\ 000$, $S_2 = -6\ 000$, $S_3 = 0$, and hence the three maximum apparent shearing stresses are 4 500, 3 000, 1 500 pounds per square inch. But from (139), taking λ as $\frac{1}{3}$, the true axial and lateral stresses are $T_1 = +5\ 000$, $T_2 = -7\ 000$, $T_3 = +1\ 000$, whence the three maximum true shearing stresses are 6 000, 4 000, 2 000 pounds per square inch. Here the true axial stress is 67 percent greater than the apparent, while the true shearing stresses are 33 percent greater than the apparent ones.

Prob. 140. Compute the maximum shearing unit-stresses, both apparent and true, for the data given in Problem 139.

ART. 141. COMBINED SHEAR AND AXIAL STRESS

Formulas were deduced in Art. 105 for the maximum apparent stresses of tension, compression, and shear, due to the simultaneous action of an axial load and a cross-shear. It was shown that there are two planes at right angles to each other upon which there are no shearing stresses, one being under normal tension S_1 and the other under normal compression S_2 . Let S be a given axial unit-stress of tension and S_s the shearing unit-stress acting at right angles to it. Then the formulas give the following values of the maximum tensile stress S_1 , the maximum compressive unit-stress S_2 , and the maximum shearing unit-stress S' ,

$$S_1 = \frac{1}{2}S + (S_s^2 + \frac{1}{4}S^2)^{\frac{1}{2}} \quad S_2 = \frac{1}{2}S - (S_s^2 + \frac{1}{4}S^2)^{\frac{1}{2}} \quad S' = (S_s^2 + \frac{1}{4}S^2)^{\frac{1}{2}} \quad (141)$$

It is here seen that the value of S' is the same as that of $\frac{1}{2}(S_1 - S_2)$. Hence when S_1 and S_2 have been computed, the subsequent discussion is exactly like that of the last article. When S is tension, as above considered, S_1 is tension and S_2 is compression; when S is compression, S_1 is compression and S_2 is tension.

Let λ be the factor of lateral contraction, and T_1 and T_2 the true internal unit-stresses corresponding to S_1 and S_2 . Then, by (139), the value of T_1 is $S_1 - \lambda S_2$ and that of T_2 is $S_2 - \lambda S_1$; substituting in these the above values of S_1 and S_2 , there are found,

$$\left. \begin{aligned} T_1 &= \frac{1}{2}(1 - \lambda)S + (1 + \lambda)(S_s^2 + \frac{1}{4}S^2)^{\frac{1}{2}} \\ T_2 &= \frac{1}{2}(1 - \lambda)S - (1 + \lambda)(S_s^2 + \frac{1}{4}S^2)^{\frac{1}{2}} \end{aligned} \right\} \quad (141)'$$

from which T_1 and T_2 may be directly computed. For steel the mean value of λ is $\frac{1}{3}$, and hence for this material,

$$T_1 = \frac{1}{3}S + \frac{4}{3}(S_s^2 + \frac{1}{4}S^2)^{\frac{1}{2}} \quad T_2 = \frac{1}{3}S - \frac{4}{3}(S_s^2 + \frac{1}{4}S^2)^{\frac{1}{2}}$$

are the true maximum tensile and compressive unit-stresses due to an axial unit-stress S and a shearing unit-stress S_s acting at right angles to it. The true maximum shearing unit-stress acts along a plane that bisects the directions of S_1 and S_2 and its value is $T' = \frac{1}{2}(T_1 - T_2)$. The directions of T_1 and T_2 are the same as those of S_1 and S_2 , and may be found from the expression for $\cot 2\phi$

deduced in Art. 105, namely, $\cot 2\phi = -\frac{1}{2}S/S_s$, where the two values of ϕ give the angles included between the direction of S and those of the planes against which S_1 and S_2 act.

As a numerical illustration, take the case of a steel bolt subject to an axial tension of 2 000 and to a cross-shear of 3 000 pounds per square inch. Here $S = +2\ 000$, $S_s = 3\ 000$, from which $S_1 = +4\ 160$ and $S_2 = -2\ 160$ pounds per square inch are the apparent maximum unit-stresses of tension and compression, and their directions are given by $\cot 2\phi = -\frac{1}{3}$. The two values of ϕ then are $54^\circ 13'$ and $144^\circ 13'$, which show that S_1 makes an angle of $35^\circ 47'$ and S_2 an angle of $54^\circ 13'$ with the axis of the bolt. The true unit-stresses have the same directions and their values are $T_1 = +4\ 880$, $T_2 = -3\ 550$ pounds per square inch. For the shearing unit-stresses the maximum values are $S' = 3\ 160$ and $T' = 4\ 220$ pounds per square inch. Here the true maximum tension is 17 percent greater than the apparent, the true compression is 64 percent greater, and the true shear is 33 percent greater. There is also a third true compression $T_3 = -670$, and two other true shears smaller than S' which act along planes parallel to S_1 . It thus appears that the actual internal stresses corresponding to the deformations of the material are far more complex than and quite different in value from those computed by the common theory.

The above discussion considers a bar subject only to a single axial stress S and to a cross-shear S_s . This is a very common case in engineering practice, but other cases far more complex occasionally occur where the bar is subject to both axial and lateral stresses and to shears in different directions. The methods of treating these cases will be explained in Arts. 177 and 178.

Prob. 141a. A horizontal bar of cast iron, $2 \times 2 \times 6$ inches, is under an axial compression of 20 000 pounds, and under shear from a uniform vertical load of 8 000 pounds which rests upon it. Compute the maximum unit-stresses, both apparent and true, and find the directions which they make with the axis of the bar.

Prob. 141b. What must be the value of S_s in (141) in order that S_1 and S_2 may be equal?

ART. 142. TRUE STRESSES IN BEAMS

The first set of formulas in the last article furnishes the means of ascertaining the maximum apparent stresses at any point in the beam, S being the horizontal unit-stress for that point as computed from the flexure formula and S_s the shearing unit-stress as determined by Art. 108. From these the apparent unit-stresses S_1 and S_2 which act at the given point are computed and then the true unit-stresses T_1 and T_2 . The discussion in the last article also shows that the directions of T_1 and T_2 are the same as those of S_1 and S_2 , and hence the lines of maximum stress shown in Fig. 109 apply equally to both. At the upper and lower surfaces of the beam where the shear is zero, the unit-stress S , computed from the flexure formula, is also the true unit-stress; at the neutral surface where the shear is the greatest, the true normal stresses on planes where there is no shear are greater than the apparent ones. Since the unit-stresses on the upper and lower surfaces are greater than for any other points in a cross-section, it is never necessary in practical problems to investigate the true stresses in a beam.

The upper surface of a simple beam is in compression while the lower surface is in tension. The width of the beam hence suffers a lateral expansion in its upper part and a lateral contraction in its lower part, so that a rectangular section becomes a trapezoidal one when the load is applied. This change is so slight that it is rarely observed, but there is little doubt that it can be detected by precise measurement. For example, take a steel beam, 6×6 inches in section and so loaded that the flexural unit-stress at the dangerous section is 30 000 pounds per square inch. The unit-shortening of the upper surface and the unit-elongation of the lower surface will then be $\epsilon = 30\,000/30\,000\,000 = 0.001$; and hence the total lateral contraction of the width of the beam at the dangerous section will be $e = \frac{1}{3} \times 0.001 \times 6 = 0.002$ inches, a quantity that can be easily measured with precise calipers.

A uniform load resting upon the upper surface of a simple

beam produces a vertical compression which is to be combined with the horizontal compressive unit-stress in order to obtain the true stresses. Let S_1 be the flexural unit-stress and S_2 the compressive unit-stress due to the uniform load. Then the true maximum compressive unit-stress in a horizontal direction is $T_1 = S_1 - \lambda S_2$, while that in a vertical direction is $T_2 = S_2 - \lambda S_1$. It thus appears that each compression diminishes the effect of the other. Usually S_2 will be small compared with S_1 , so that computations are rarely necessary.

A concentrated load resting upon the upper surface of a simple beam may, however, produce a high unit-stress S_2 . The experiments made by J. B. Johnson in 1893, on the contact between the surface of a car wheel and a railroad rail, showed that the mean compressive unit-stress was about 80 000 pounds per square inch. A heavy pressure like this entirely alters the distribution of the stresses and the directions of the lines of maximum stress in its vicinity, for T_1 may become tension, if the elongation due it can occur. In the contact of wheels on rails, however, there is no permanent deformation due to the heavy vertical compressive stress, which indicates that lateral flow or elongation could not occur. Under such circumstances there is doubt as to the correctness of the applicability of the preceding theory to the determination of the true stresses. The case is perhaps analogous to that of stresses due to change in temperature, where heavy stresses may arise with but little change in length; thus, a fall of 200 degrees Fahrenheit in temperature will produce a unit-shortening of about 0.0014, but this is probably sufficient to break a wrought-iron bar, if it is prevented from shortening and is under an initial tension of about 30 000 pounds per square inch.

Prob. 142*a*. A steel I beam, 20 inches deep and weighing 80 pounds per linear foot, carries a uniform load of 24 000 pounds on a span of 30 feet. Compute the values of S_1 and S_2 at the dangerous section and find the true stresses.

Prob. 142*b*. How must a simple beam be loaded so that the elastic curve is an arc of a circle?

ART. 143. STRESSES DUE TO SHEAR

It is shown in Art. 6, and also in Art. 105, that forces of tension or compression acting upon a body produce not only internal tensile or compressive stresses, but also internal shearing stresses. Conversely, an external shear acting upon a body produces in it not only internal shearing stresses, but also internal tensile and compressive stresses.

For example, the rectangle $ABCD$ in the web of a plate girder, shown in Fig. 143a, may be considered. Let V be the shear at the sections AB and CD , which are taken very near together so that the weight in the rectangle itself can be disregarded. This vertical shear or couple must be accompanied by a horizontal shear V_1 , which in this case is caused by the resistance of the flange rivets. Let the thickness of the material be one unit; then if S and S_1 are the shearing unit-stresses, their values are $S = V/AB$ and $S_1 = V_1/AD$. Now taking either A or D as an axis of moments, the equation of moments is $V \times AD = V_1 \times AB$, and hence $V/AB = V_1/AD$, that is, the shearing unit-stresses S and S_1 are equal. This is without regard to the weight of the rectangle itself, which will cause a slight modification, because the V on the left will then be greater than the V on the right. But if AD is very small, the conclusion is strictly true that the horizontal shearing unit-stress is equal to the vertical shearing unit-stress.

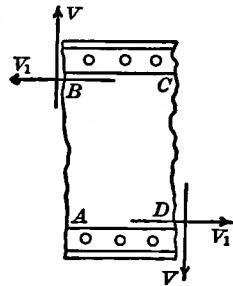

Fig. 143a

The vertical and horizontal shears in the above figure tend to deform the rectangle into a rhomboid, thus causing tension along the diagonal BD and compression along the diagonal AC . At every point in the rectangle, then, the vertical shearing unit-stress S and the equal horizontal unit-stress S_1 combine to cause the tension and the compression $2^{\frac{1}{2}}S$ acting with inclinations of 45 degrees to the shears. Dividing each of these by the area $2^{\frac{1}{2}}$ normal to its direction, it is seen that both the ten-

sile and the compressive unit-stress is S ; that is, a shearing unit-stress causes equal tensile and compressive unit-stresses in directions making angles of 45 degrees with the shears.

This may also be proved from the discussion in Art. 105 or from Art. 141. Thus, in formula (141) let the axial tensile unit-stress S be made zero, then the maximum tensile and compressive unit-stresses S_1 and S_2 are each equal to S_s . If, however, $S_s = 0$, then the maximum shearing unit-stress is $\frac{1}{2}S$. Accordingly an axial tension or compression on a bar produces a shearing unit-stress equal to one-half the tensile or compressive unit-stress, but the action of a shear produces tensile and compressive unit-stresses equal to the shearing unit-stress itself. This may be regarded as a most fortunate arrangement in view of the fact that the shearing strength of materials is usually less than the tensile strength.

The above relates to apparent stresses only. The true stresses T_1 and T_2 , corresponding to S_1 and S_2 , are those that correspond to the actual deformations, and by (139) their values are $T_1 = S_1 - \lambda S_2$ and $T_2 = S_2 - \lambda S_1$, where S_1 and S_2 are to be taken as positive for tension and as negative for compression. For example, let Fig. 143b represent one face of a cube which is subject to the shearing unit-stress S of 5 000 pounds per square inch, each edge of the cube being unity. The distortion

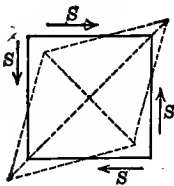

Fig. 143b

of the square is shown greatly exaggerated by the broken lines, and both the tension along the longer diagonal and the compression along the shorter diagonal are equal to 5 000 pounds per square inch. Now if the factor of lateral contraction λ is $\frac{1}{4}$, then the true stress along the longer diagonal is $T_1 = +6\,250$, while that along the shorter one is $T_2 = -6\,250$ pounds per square inch, so that the true stresses of tension and compression are 25 percent greater than the apparent ones.

It may be noted that while shear produces distortions, it does not cause changes in the volume of a body. Thus, for the above figure, let e be the elongation or shortening of the diagonals,

then the length of the longer diagonal is $2^{\frac{1}{2}} + e$ and that of the shorter diagonal is $2^{\frac{1}{2}} - e$; the area of the rhombus then is $\frac{1}{2}(2^{\frac{1}{2}} + e)(2^{\frac{1}{2}} - e) = 1$, which is the same as that of the square before it was subjected to shear.

Prob. 143. A steel beam, $2 \times 2 \times 6$ inches, is supported at its ends and has a concentrated load 40 000 pounds at its middle. Compute by Art. 108 the greatest shearing stress which occurs at the neutral axis, and then find the true tensile and compressive unit-stresses which exist there. Draw a diagram showing the directions of these stresses.

ART. 144. TRUE STRESSES IN SHAFTS

When a round shaft is acted upon by torsion alone, the stresses are those of shearing, and these act along every section normal to the axis, the maximum S_s occurring at the surface (Art. 90). Any square in one of these normal sections is hence acted upon by two equal and opposite shears, as shown in Fig. 143*b*, and these produce apparent stresses of tension and compression in directions bisecting those of the shears. The discussion of the last article applies in all respects to this case, and from it the true stresses of tension and compression are seen to be each equal to $(1 + \lambda)S_s$.

When a horizontal shaft carries a load, flexural stresses come into action and these must be combined with the shearing stresses in the manner explained in Art. 106. The formulas (141) give the apparent and formulas (141)' give the true unit-stresses due to the combination of torsion and flexure; in these S is to be first computed from the flexure formula (41), while S_s is to be computed from the torsion formula (90) or from the special formulas of Art. 92. From the last paragraph of Art. 143, it is to be concluded that there is no change in volume of the shaft under torsion alone; the same is closely the case when flexure is added to the torsion, because the decrease in volume due to the tension is practically the same as the increase due to the compression (Art. 13).

The compression on the upper surface of a shaft due to a load, or that on the lower surface due to the upward reaction

of a bearing, produces stresses which act normally to the flexural stresses of tension and compression, while they are also at right angles to the shearing stresses due to the transmitted torsion. A formula for discussing this and other more difficult cases is deduced in Art. 177, and an application of it to the above case will now be given. Let S_x be the horizontal flexural unit-stress at the surface of the shaft, S_y the vertical compressive unit-stress due to the load or bearing, and S_s the shearing unit-stress due to the transmitted torsion. Then in formula (177) the value of A is $S_x + S_y$, that of B is $S_x S_y - S_s^2$, and that of C is zero, and it reduces to the form

$$S^2 - (S_x + S_y)S + S_x S_y - S_s^2 = 0$$

in which the two values of S are the maximum tensile and compressive unit-stresses; solving the quadratic equation there results,

$$S = \frac{1}{2}(S_x + S_y) \pm (S_s^2 + \frac{1}{4}(S_x + S_y)^2 - S_x S_y)^{\frac{1}{2}} \quad (144)$$

where the value of S found by using the plus sign before the radical will be tension or compression according as the value of $\frac{1}{2}(S_x + S_y)$ is tension or compression. When either S_x or S_y is zero, these values are the same as those given by (141).

As a numerical example, let the flexural compressive unit-stress S_x under a load or in a bearing of a horizontal steel shaft be 3 000, the vertical compressive unit-stress S_y due to the load or bearing be 1 200, and the shearing unit-stress S_s due to the torsion be 6 000, all in pounds per square inch. Formula (144) then gives $S_1 = 8 200$ pounds per square inch compression, and $S_2 = 4 000$ pounds per square inch tension for the maximum normal stresses; also $S' = \frac{1}{2}(S_1 - S_2) = 6 100$ pounds per square inch is the maximum shearing stress. Lastly, by (139) and (140), the corresponding true stresses are for compression $T_1 = 9 500$, for tension $T_2 = 6 700$, and for shear $T' = 8 100$ pounds per square inch. In common practice it will be considered that the greatest compression is 3 000 and the greatest shear is 6 000 pounds per square inch, but the result of this investigation shows that the true compression is more than three times as great and the true shear about 40 percent greater.

Prob. 144. Show that the two roots of (144) are always real whatever may be the values of S_x , S_y , and S_z . What are these roots when S_z is 0?

ART. 145. PURE STRESSES

The term 'pure stress' is employed for cases where only one kind of stress exists. When a plane is acted upon only by forces normal to it, the stress on the plane is either tensile or compressive and this is sometimes called 'pure normal stress'. When a plane is acted upon only by forces parallel to it, the stress on the plane is that of shearing, and this is sometimes called 'pure shearing stress'. Upon most planes in the interior of a stressed body, there act both normal and shearing stresses. The preceding articles show how to find the maximum unit-stresses S_1 and S_2 which act normally against certain planes upon which there are no shearing stresses.

Another use of the term 'pure stress' is with respect to any and all planes that can be imagined to be drawn in the interior of a body. When the forces acting upon the body have such values that there can be no shearing stresses within it, the case is called one of 'pure internal normal stress'. Referring to Fig. 139 and to the reasoning in the last paragraph of Art. 140, it is seen that there can be no shearing stresses on any planes within the body, when $S_1 = S_2 = S_3$; this is the case where the unit-stresses acting on the six faces of a parallelepiped are all equal. The same result follows when a body is acted upon by equal compressive forces in all directions, as occurs under hydrostatic pressure. Under no other circumstances can the interior of a stressed body be free from shearing stress, and hence this is the only case of pure internal normal stress.

There is no case of a body having only internal shearing stress, for the discussion of Art. 143 shows that internal shear must always be accompanied by normal stresses which act in directions bisecting those of the two conjugate shears. There may, however, be certain planes within a body upon which only shearing stresses act. In order to find such planes, let Figs. 140*a* and 140*b* be again considered, and let the forces shown in the latter be resolved

normal to the diagonal δz . Let S be the normal unit-stress of tension or compression on δz ; then the total stress on that diagonal is $S\delta z$ and this is equal to $S_1\delta y \cdot \sin\theta + S_2\delta x \cdot \cos\theta$. Replacing $\delta x/\delta z$ and $\delta y/\delta z$ by their values $\cos\theta$ and $\sin\theta$, there is found $S = S_1 \sin^2\theta + S_2 \cos^2\theta$. Now when $S = 0$, there is no normal stress on the plane that makes the angle θ with the direction of S_1 ; this occurs when $\tan\theta = (-S_2/S_1)^{\frac{1}{2}}$ and on the plane thus determined only shearing stresses are acting. It is seen that no value of θ is possible unless S_1 and S_2 have contrary signs, that is, one must be tension and the other compression. When $S_2 = -\frac{1}{4}S_1$, then $\tan\theta = \pm 0.5$ and $\theta = \pm 26\frac{1}{2}^\circ$; when $S_2 = -S_1$, then $\tan\theta = \pm 1$ and $\theta = \pm 45^\circ$; when $S_2 = -3S_1$, then $\tan\theta = \pm 1.73$ and $\theta = \pm 60^\circ$, and so on. Hence for each negative value of S_2/S_1 there are two planes equally inclined to the direction of S_1 upon which only shearing stresses act. The following figures show the three cases computed above.

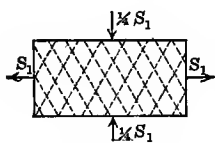

Fig. 145a

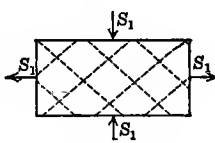

Fig. 145b

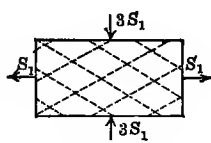

Fig. 145c

The shearing unit-stresses on these planes of true shear are not as great as those on the planes bisecting the directions of S_1 and S_2 , for on the latter the maximum shears exist. For Fig. 145b, however, where the normal tension and compression are numerically equal, the planes of pure shear coincide with those of maximum shear; this is the case most frequently mentioned as one of pure shear (Fig. 145b), but the above investigation shows that there may be many other cases.

The term 'pure flexure' is used for a part of a beam where there are no vertical shears. For instance, take a simple beam and subject it to two concentrated loads, each equal to P and placed at equal distances from the supports. Then there is no vertical shear between the loads, and hence the flexural stresses above the neutral surface are pure compression, while those

below it are pure tension. In testing a beam it is sometimes advantageous to subject it to two equal concentrated loads placed at equal distances from the middle; thus the bending moment between the loads is constant, and the changes of length of the fibers are uniform at equal distances from the neutral surface. The experiments of Talbot on steel-concrete beams, described in Art. 116, were made in this way. It must be noted, however, that there prevail in all directions, except horizontally and vertically, shearing unit-stresses accompanying the pure tension and compression; if S is the flexural unit-stress at any point between the loads, then $\frac{1}{2}S$ is the maximum shearing unit-stress which makes angles of $\pm 45^\circ$ with the direction of S .

Prob. 145*a*. In the formula $S_n = S_1 \sin^2\theta + S_2 \cos^2\theta$, let S_1 be larger than S_2 . Show that the values of S_n cannot be greater than S_1 nor less than S_2 . This is the equation of a curve in polar coordinates, S_n being the radius vector for the variable angle θ ; what kind of a curve is it?

Prob. 145*b*. A parallelepiped is acted upon by normal unit-stresses of 6 400 and 2 800 pounds per square inch in directions at right angles to each other, the first being tension and the second compression. Compute the pure shearing unit-stress and the maximum shearing unit-stress, and find their directions.

ART. 146. INTERNAL FRICTION

In all the preceding discussions, the applied forces and the internal stresses have been supposed to be in equilibrium, this being the case where the applied forces have attained the full magnitudes so that no further deformation of the body occurs. Other considerations enter during the period while the deformations are occurring under applied forces which increase from zero up to their final values. During this period there are motions of the molecules, and this motion is resisted by internal friction, just as the motion of a book upon a table is opposed by the friction between the surfaces of contact. The planes of maximum stress, found in the preceding articles, are hence not the cor-

rect planes of greatest stress during the period while the deformation of a body is occurring.

The subject of internal friction was first recognized in the experiments made by Tresca, about 1860, on the flow of metals under high compressive stress, but it was not until after 1890 that it received careful attention. In 1893 the remarkable discovery was made by Hartmann that lines of stress became visible on the surface of polished metallic specimens when the elastic limit of the material was reached or surpassed, and that these lines remained after the loads were removed. Fig. 146*a* represents such lines for specimens of rectangular section; and it is seen that in compression they make an angle with the axis less than 45 degrees, while in tension this angle is greater than 45 degrees. It was observed that the sum of these two angles was always 90 degrees for the same metal and that the directions of the lines were independent of the size and length of the specimen and of the unit-stress. The number of lines, however, increased as the unit-stress increased from the elastic limit to the ultimate strength. For the case of tension, Hartmann found that the angle ϕ which the lines make with the axis of the bar was 65 degrees for nickel steel, 63 degrees for tempered steel, and 58 degrees for annealed steel; for compression the angle θ between the lines and the axis was the complement of ϕ .

When round specimens of metal with polished surfaces were subjected to stresses above the elastic limit of the material, it was found that the lines were not straight but spiral, as shown in Fig. 146*b*, these spirals making the same angle with the axis as the straight lines on the rectangular specimens. Under the microscope it was noted that, in general, these lines were depressions below the intermediate surfaces and that the larger lines seen by the naked eye were really several small lines very near together. Hartmann also experimented on spheres and beams, finding that curved lines appeared on their polished surfaces when the elastic limit of the material was reached or surpassed, their directions always remaining the same in the same specimen. The lines for a beam shown in his book *Déformations*

dans les Métaux (Paris, 1896) have very little resemblance to any of the theoretic lines of maximum stress which are shown in Fig. 109.

These interesting lines probably indicate the directions of the planes or surfaces on which the sliding or shearing of the material is beginning to occur. This supposition is strengthened by the phenomena of the rupture of brittle materials under compression, where it is found that the failure ultimately takes place by shearing along planes inclined to the axis of the specimen, as Fig. 169*b* shows for cement and timber. These planes make angles with the axis varying from 10 to 40 degrees, the angle for stone usually being about 20 and that of cement and concrete about 30 degrees. Also it is observed that metallic bars under tension sometimes rupture with an oblique or cup-like fracture, the inclination of which to the axis is 50 degrees or more. It may therefore be regarded as almost demonstrated that materials begin to fail, both in tension and compression, by shearing along oblique planes, and that the commencement of the failure is at the time the elastic limit of the material is reached.

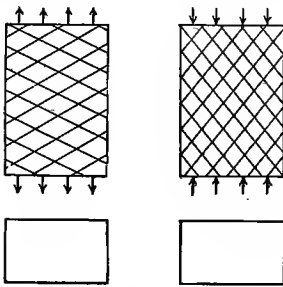
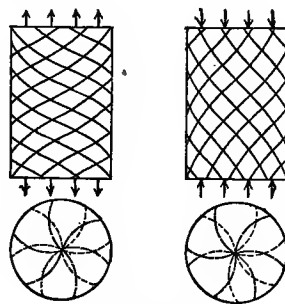
Fig. 146*a*Fig. 146*b*

The theory of internal stress, set forth in the preceding articles of this chapter, shows that the maximum shearing unit-stresses, both apparent and true, are those upon planes making angles of 45° with the axis of the bar. Since the actual planes of failure are greater than 45° for tension and less for compression, it must be concluded that some resisting force acts during the progress

of the deformation which has not heretofore been considered, and this resistance is probably that of friction. Much attention has been given to this question since 1895, and the work of Rejtö, published in 1897, endeavors to account for the brittleness, plasticity, ductility, and even the strength of materials, by the help of coefficients of internal friction.

Prob. 146. Consult Rejtö's *Innere Reibung der festen Körper*, and explain his formula for the tensile strength of materials.

ART. 147. THEORY OF INTERNAL FRICTION

When one surface begins to slide on another, the ratio of the force parallel to the sliding surface to the normal pressure is called the coefficient of friction; it is an abstract number and may be designated by ν . Let N be the normal pressure or stress between the two bodies and F the force which just begins to cause motion when it acts parallel to the surface of contact, then the approximate law of sliding friction is given by $F = \nu N$. This law may be applied, tentatively at least, to the case of a bar under axial stress, during the period while the stress is increasing up to its final value, and it may be supposed that sliding or shearing is then beginning to occur along surfaces indicated by the lines and planes described in the last article. There is hence a coefficient of internal friction μ , which is not necessarily the same as that of sliding friction but which may be used in the same manner by means of the law $F = \mu N$.

The simplest case is that of a bar subject to axial compression, as in Fig. 147*a*. Let the section area be unity and S be the compressive unit-load which causes the equal axial unit-stress S on all planes normal to the axis. Let any plane mn be drawn cutting this bar, and let θ be the angle which it makes with the axis. When there is no axial stress in the bar, there exists normal to this plane a molecular unit-force S_0 which binds together the two parts so that no motion can occur. When the axial compressive unit-stress is applied, this causes a compressive stress $S \sin \theta$ normal to the plane, and since the area of the plane is

$1/\sin\theta$, the compressive unit-stress is $S \sin^2\theta$. The total normal pressure per square unit on the plane then is $N = S_0 + S \sin^2\theta$. The force acting parallel to the plane is $S \cos\theta$, or $F = S \cos\theta \sin\theta$ for each square unit. Accordingly, if motion is just beginning,

$$S \cos\theta \sin\theta = \mu(S_0 + S \sin^2\theta) \quad \text{or} \quad S = \mu S_0 / (\sin\theta \cos\theta - \mu \sin^2\theta)$$

Now let θ be regarded as varying from 0 to 90° , then the unit-load S required to cause motion will vary from ∞ to S_0 , and it follows that the motion will actually begin along that plane which has such a value of θ that S shall be a minimum; or the value of S which causes motion to begin is less for the plane of motion than for any other plane. This requires that $\sin\theta \cos\theta - \mu \sin^2\theta$ shall be a maximum, and the value of θ which renders it such is found to be given by $\cot 2\theta = \mu$. Hence,

$$\mu = \cot 2\theta \quad \mu S_0 = \frac{1}{2} S \tan\theta = \frac{1}{2} S (-\mu + \sqrt{1 + \mu^2}) \quad (147)$$

gives the relations between the quantities μ , θ , and S_0 . The observed angle θ is always less than 45° ; for different qualities of steel, θ lies between 25° and 32° and hence the coefficient of internal friction lies between 0.84 and 0.49.

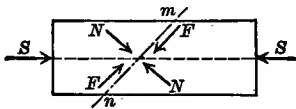

Fig. 147a

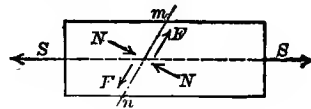

Fig. 147b

In considering the case of tension shown in Fig. 147b, let ϕ be the angle which a plane mn makes with the axis. Then the normal unit-pressure on the plane is $S_0 - S \sin^2\phi$, and the force per unit of area acting parallel to the plane is $S \sin\phi \cos\phi$. For the case of incipient motion, the law of friction then gives,

$$S \cos\phi \sin\phi = \mu(S_0 - S \sin^2\phi) \quad \text{or} \quad S = \mu S_0 / (\sin\phi \cos\phi + \mu \sin^2\phi)$$

and, by the same reasoning as before, it is concluded that the actual plane of motion is that which renders $\sin\phi \cos\phi + \mu \sin^2\phi$ a maximum, and this maximum obtains when $\cot 2\phi = -\mu$. Accordingly,

$$\mu = -\cot 2\phi \quad \mu S_0 = \frac{1}{2} S \tan \phi = \frac{1}{2} S (\mu + \sqrt{1 + \mu^2}) \quad (147)'$$

are the equations applicable to tension in which ϕ is observed to be always greater than 45 degrees.

Since the coefficient of internal friction μ must be regarded as a constant for the same material, it follows that the angles θ and ϕ are necessarily complementary, for by equating the two values of μ the relation between the angles is given by $\theta + \phi = 90^\circ$. The above theory may hence be said to explain why it is that the lines described in the last article make an angle with the axis which is less than 45 degrees for compression and greater than 45 degrees for tension, and why these angles are complementary.

It seems a reasonable assumption to regard μS_0 as the ultimate shearing strength S_s of the material, since μS_0 equals the force per unit of area which will cause shearing along the plane. When a brittle specimen is ruptured by direct compression, failure generally occurs by shearing along one or more planes which make an angle θ with the axis less than 45 degrees, and accordingly $S_s = \frac{1}{2} S_c \tan \theta$ may be written as a tentative formula for the relation between the ultimate shearing strengths S_s and the ultimate compressive strength S_c . The following are rough approximate values of θ as observed in compressive tests, together with the values of μ and S_s/S_c as computed from (147):

Anthracite Coal	$\theta = 15^\circ$	$\mu = 1.73$	$S_s = 0.13 S_c$
Sandstone	$\theta = 20^\circ$	$\mu = 1.19$	$S_s = 0.18 S_c$
Hard Brick	$\theta = 25^\circ$	$\mu = 0.84$	$S_s = 0.23 S_c$
Cement and Concrete	$\theta = 30^\circ$	$\mu = 0.58$	$S_s = 0.29 S_c$
Cast Iron	$\theta = 35^\circ$	$\mu = 0.36$	$S_s = 0.35 S_c$

These computations indicate that the coefficient of internal friction is the highest and that the ratio of the shearing to the tensile strength is the lowest for the most brittle material. Thus for cast iron the shearing strength is 35 percent of the compressive strength, according to this computation, while for anthracite coal it is only 13 percent.

When two bars of steel are stressed up to their elastic limits, one in compression and the other in tension, the elastic limit

is closely the same for both bars, and it hence seems that S in (147) should be the same as S in (147)', which requires θ and ϕ to be equal. This is a result altogether at variance with experiment, and it must hence be concluded either that S_0 in tension is different from S_0 in compression or that the above reasoning is defective in failing to include one or more elements that must ultimately be introduced in order to perfect the theory. Much work still remains to be done on this important subject, both in theory and by experiment, before definite ideas can be formed regarding the true internal stresses which prevail while a body is undergoing deformations. The theory of Arts. 139-145 relates only to static stresses, namely, to those which occur when the applied forces have attained their full magnitudes, so that both external and internal equilibrium prevails. This static theory appears to be correct in every detail for static stresses which do not surpass the elastic limit of the material, but the permanency of the lines of shearing seen upon polished metallic specimens, seems to throw a doubt upon its entire applicability to cases where the elastic limit is surpassed, even though complete equilibrium exists. As far as true internal static stresses are concerned, this theory is indeed not necessarily valid, for formulas (139) apply only within the elastic limit, but for the apparent static stresses it should be valid for all cases. In order that the full and complete truth may be ascertained, further studies on internal friction and on internal molecular forces are absolutely necessary.

In conclusion it may be noted that the idea of internal friction throws light upon the fatigue of materials under repeated stresses (Art. 137). For the case of compression where heat is evolved for stresses both below and above the elastic limit, it is not difficult to see that energy is expended in changing the positions of the molecules at each application of stress; for the case of tension the same occurs for stresses higher than about three-fifths of the elastic limit. The material is hence fatigued or changed in structure by the internal friction, and this change should be greater for large ranges of stress than for small ones. Undoubtedly the complete explanation of fatigue is closely allied

to that of internal friction and to changes in internal molecular forces. The indications are that any stress, however small, will produce fatigue when it is repeated a number of times in a material that has a crystalline structure. Steel is such a material and the various crystals that are seen in it under the microscope have cleavage planes which are weakened by the detrusion due to repeated stress.

Prob. 147*a*. Five constants have thus far been used in this volume as applicable to a material when stressed up to its elastic limit in tension. What are these constants?

Prob. 147*b*. Consult *The Iron and Steel Magazine* for July, 1905, and read an article on the failure of an iron plate through fatigue. Also consult other volumes of this periodical, and ascertain the names and characteristics of the various crystals which are seen in steel.

CHAPTER XVI

GUNS AND THICK CYLINDERS

ART. 148. FACTS AND PRINCIPLES

THE discussion of pipes under internal pressure, given in Art. 30, was made under the assumption that the thickness of the pipe is small compared to its diameter, so that the tensile stress of the metal of the pipe might be regarded as uniformly distributed. Pipes under high internal pressure have thicknesses sometimes nearly equal to the inside diameter, and in such the tensile stresses are not uniformly distributed. The steel pipe used to transmit water pressure to the large forging press of the Bethlehem Steel Company, in South Bethlehem, Pa., has an inside diameter of 16 inches, a thickness of 8 inches, and it is subject at times to a pressure of 5 600 pounds per square inch. The theory of the investigation and design of thick pipes will be developed in this chapter.

The guns used in modern warfare are subject to high internal pressures produced by the explosion of the powder. These pressures are measured by noting their effects in shortening small copper cylinders and comparing these deformations with those produced by known loads in a testing machine. In this manner it has been ascertained that powder pressures of 50 000 pounds per square inch are often produced during the firing of a gun, while the extreme pressure of 88 000 pounds per square inch has been observed in a special experiment. In order that the metal of the gun may not be stressed beyond its elastic limit under these heavy pressures, it is necessary that the thickness should be large. For inside diameters greater than 3 inches, the gun is generally formed of two or more concentric cylinders, the inner one being called the 'tube' and the others 'hoops'; these hoops are shrunk upon the tube (Art. 32) so that they produce compression in it and thus enable it to carry a heavier powder pressure

than a solid tube of the same total thickness. The first hoop around the gun tube is often called the 'jacket'.

Fig. 148 gives a longitudinal and a cross section of a gun having two hoops, the breech block that closes the powder chamber *A* being omitted. This breech block can be swung open to admit the projectile and the powder case, the position of the former being at *B*. Before the explosion the breech block is swung into place and locked. At the instant of the explosion the pressure of the gas is the greatest since it is then confined to the spaces *A* and *B*; this part of the gun is called the breech, and here it is that the greatest thickness is required; over the breech and extending some distance forward, the figure shows two hoops *E* and *F* surrounding the gun tube *D*. As the projectile moves toward the muzzle, the gas occupies a larger volume, so that its pressure decreases and becomes zero as the projectile leaves the gun. The tube *C* has spiral grooves cut in its inside surface, which cause the projectile to have a rotary motion. In designing a gun of this kind it is required that the section areas at the forward end of each hoop shall be sufficient to resist the maximum powder pressure which can there be exerted.

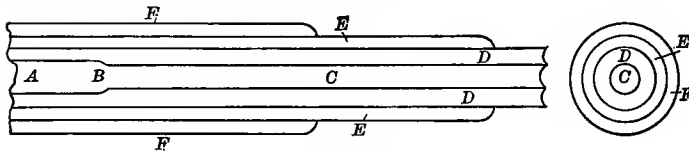

Fig. 148

Modern guns are made of hard steel, often of fluid compressed steel, which has an elastic limit of about 50 000 and an ultimate strength of about 90 000 pounds per square inch. The allowable working stresses are large, in some cases as large as the elastic limit. Most careful workmanship and rigid inspection are exercised in their manufacture, and constant improvements are made in their design. These modern guns have been entirely developed since 1870, prior to which time cast-iron cannon were mainly in use. They are usually designed for a powder pressure of 50 000 pounds per square inch.

Prob. 148. The diameter of a powder chamber is $8\frac{1}{2}$ inches and that of the projectile is 8 inches, while the pressure during the explosion is 48 000 pounds per square inch. Compute the total forward pressure on the projectile and the total backward pressure on the breech block. Where does the difference of these pressures take effect?

ART. 149. LAME'S FORMULA

Let a thick hollow cylinder, shown in Fig. 149*a*, be subject to a pressure R_1 on each square unit of the inside surface and to a pressure R_2 on each square unit of the outside surface. The inside pressure may be produced by the expansion of a gas and the outer pressure by the atmosphere or by other causes. It is required to determine the internal stresses produced by these pressures at any point in the cylindrical annulus not very near the end. The length of the cylinder is to be regarded as considerably longer than the outer diameter, in order that the disturbing influence of the ends may not affect the reasoning.

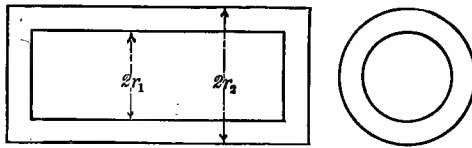

Fig. 149*a*

Let r_1 and r_2 be the inside and outside radii; then the inside pressure on the end of the closed cylinder is $\pi r_1^2 R_1$ and the outside pressure on that end is $\pi r_2^2 R_2$. The usual case is that where the inside is greater than the outside pressure, and then $\pi(r_1^2 R_1 - r_2^2 R_2)$ is the longitudinal tension in the annulus. For any part of the cylinder, not very near the end, this tension must be uniformly distributed over the cross-section of the annulus. The longitudinal tensile unit-stress S_0 in the annulus is hence a constant for all points, and its value is found by dividing the total tension by the section area a ; whence,

$$S_0 = (r_1^2 R_1 - r_2^2 R_2) / (r_2^2 - r_1^2)$$

This longitudinal unit-stress, together with the radial pressures,

causes a longitudinal elongation of the cylinder, which is also to be regarded as uniform for all parts of the annulus, not very near the end. Under these assumptions, the theory of true stress given in Art. 139 may be applied to the determination of the unit-stresses at any point in the cylindrical annulus.

Let x be the distance from the axis of the cylinder to any point in a cross-section of the cylindrical annulus. Any elementary particle is here held in equilibrium

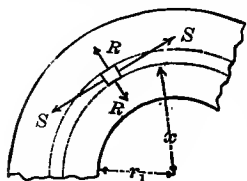

Fig. 149b

by the longitudinal unit-stress S_0 , a tangential unit-stress S , and a radial unit-stress R . The value of R is evidently intermediate between R_1 and R_2 ; in Fig. 149b both R and S are regarded as tensile. Now from Art. 139 the effective longitudinal unit-elongation of the cylinder due to these three stresses is,

$$\epsilon_0 = T/E = (S_0 - \lambda S - \lambda R)/E$$

in which λ is the factor of lateral contraction the mean value of which for wrought iron and steel is about $\frac{1}{3}$. But, as above noted, both ϵ_0 and S_0 are constant for all parts of the annulus, and it hence follows that,

$$S + R = \text{constant} \quad \text{or} \quad S + R = 2C_1$$

which is one equation between the unit-stresses S and R where C_1 is a quantity whose value is to be determined by establishing a second equation.

Let an elementary annulus of thickness δx be drawn; its inner radius is x and its outer radius is $x + \delta x$. The pressure for one unit of length in a direction perpendicular to any diameter is Rx for the inner surface and $(R + \delta R)(x + \delta x)$ for the outer surface of this elementary annulus. Thus, exactly as in the case of a thin pipe (Art. 30), the equation of equilibrium between acting pressure and resisting stress is,

$$(R + \delta R)(x + \delta x) - Rx = S\delta x \quad \text{or} \quad x\delta R + R\delta x = S\delta x$$

which is a second equation between the unit-stresses S and R .

The solution of these two equations is readily made by inserting $2C_1 - R$ for S in the second equations and integrating; then,

$$S = C_1 + \frac{C_2}{x^2} \qquad R = C_1 - \frac{C_2}{x^2} \qquad (149)$$

where C_2 is a constant of the integration the value of which is to be determined by regarding the limiting values of R , these being the inner and outer unit-pressures R_1 and R_2 . It is best to regard these unit-pressures as without sign, and then $R = -R_1$ when $x = r_1$, and $R = -R_2$ when $x = r_2$; inserting these conditions in the second formula, there result two equations from which,

$$C_1 = (r_1^2 R_1 - r_2^2 R_2) / (r_2^2 - r_1^2) \qquad C_2 = r_1^2 r_2^2 (R_1 - R_2) / (r_2^2 - r_1^2)$$

and, inserting these constants in (149), are now obtained,

$$S = \left(r_1^2 R_1 - r_2^2 R_2 + \frac{r_1^2 r_2^2}{x^2} (R_1 - R_2) \right) / (r_2^2 - r_1^2) \qquad (149)'$$

$$R = \left(r_1^2 R_1 - r_2^2 R_2 - \frac{r_1^2 r_2^2}{x^2} (R_1 - R_2) \right) / (r_2^2 - r_1^2)$$

which are Lamé's formulas for the tangential and radial unit-stresses in hollow cylinders under inside and outside pressures. In deriving these formulas, both S and R have been supposed to be tension; this will be the case if their values are positive, while a negative value will indicate compression.

The tangential unit-stress S is usually greater than the radial unit-stress R , and is the controlling factor in the design of guns and thick cylinders. It is seen to increase as x decreases, and hence it is the greatest at the inside surface of the cylinder; it may be either tension or compression, depending upon the relative values of the given radii and unit-pressures. The radial unit-stress R is always compression, its value ranging from R_1 at the inside surface to R_2 at the outside surface.

As a numerical example, let a cylinder be one foot in inside and two feet in outside diameter, the inside pressure being 600 and the outside 15 pounds per square inch. Here $r_1 = 6$, $r_2 = 12$, $R_1 = 600$, $R_2 = 15$, and the formulas become,

$$S = 180 + 28.080/x^2 \qquad R = 180 - 28.080/x^2$$

Here x varies between 6 and 12 inches, and S ranges from +960 to +375 pounds per square inch, while R ranges from -600 to -15 pounds per square inch, + denoting tension and - denot-

ing compression. The tangential unit-stress S is hence about $2\frac{1}{2}$ times greater at the inside surface of the hollow cylinder than at the outside surface.

Prob. 149. A solid cylinder is subject to a uniform radial pressure of 14 000 pounds per square inch on its surface. Prove that the radial unit-stress is uniform throughout the cylinder. Prove that the tangential unit-stress is uniform throughout the cylinder, and find its value.

ART. 150. THICK PIPES AND SOLID GUNS

Lamé's formulas have been widely used for the discussion of water pipes and solid guns. The inside unit-pressure R_1 is usually large compared to the pressure of the atmosphere on the outside surface so that the latter may be neglected. The unit-stresses S and R at any point within the cylindrical annulus then are,

$$S = r_1^2 R_1 \left(1 + \frac{r_2^2}{x^2} \right) / (r_2^2 - r_1^2) \qquad R = r_1^2 R_1 \left(1 - \frac{r_2^2}{x^2} \right) / (r_2^2 - r_1^2)$$

A discussion of this equation shows that the tangential unit-stress S is greatest when $x = r_1$ and least when $x = r_2$, and that the radial unit-stress R varies similarly. Thus, for the inside surface,

$$S_1 = R_1(r_2^2 + r_1^2)/(r_2^2 - r_1^2) \qquad \text{and} \qquad R = -R_1 \qquad (150)$$

while for the outside surface of the cylinder,

$$S_2 = R_1 \cdot 2r_1^2/(r_2^2 - r_1^2) \qquad \text{and} \qquad R = 0$$

and accordingly the greatest unit-stresses, as given by (150), are those generally used in investigation and design. The manner in which S varies throughout the annulus is shown in Fig. 150 by the arrows.

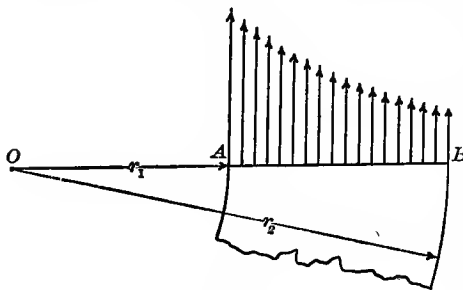

Fig. 150

It is seen that the different parts of the annulus are unequally stressed under the tangential tension, the law of variation of the unit-stresses being

that which is expressed by the first equation in formula (149).

As a special case, let the radius of the outside surface be double that of the inside surface, or $r_2 = 2r_1$. Then for the inside surface where $x = r_1$ the tangential unit-stress is $S_1 = \frac{5}{3}R_1$; for the outside surface, where $x = r_2$, it is $S_2 = \frac{2}{3}R_2$; for a point half way between these surfaces it is $\frac{2}{7}\frac{5}{3}R_1$, and all of these are tension. For the same case the radial unit-stress for the inside surface is $-R_1$, for the outside surface it is 0, and for a point half way between them it is $-\frac{7}{9}R_1$, all being compression as indicated by the minus sign.

The first formula of (150) was formerly much used for the investigation of guns and thick pipes, and it is still valuable for general discussions. As an example, let a solid steel gun have an inside diameter of 7.5 inches at the powder chamber and the thickness of the tube be 1.75 inches. Let it be required to find the greatest tensile unit-stress produced when the inside pressure from the explosion is 10 000 pounds per square inch. Here $r_1 = 3.75$ inches, $r_2 = 5.50$ inches, $R_1 = 10\ 000$ pounds per square inch. Then from the formula S_1 is found to be 27 300 pounds per square inch, which is but little more than one-half the elastic limit of gun-steel, and hence the degree of security is ample.

As an example of design, let the inside diameter be 3.25 inches, the pressure caused by the explosion 15 000 pounds per square inch, and the allowable unit-stress in tension be 30 000 pounds per square inch; and let it be required to find the outside diameter. Here $r_1 = 1.625$ inches, $R_1 = 15\ 000$, and $S_1 = 30\ 000$ pounds per square inch. Then solving for r_2 , there results,

$$r_2 = r_1[(S_1 + R_1)/(S_1 - R_1)]^{\frac{1}{2}} \quad (150)'$$

from which the outside radius r_2 is found to be 2.815 inches; thus the thickness of the tube is 1.19 inches, and its outside diameter is 5.63 inches.

When formula (150) is applied to a thin pipe, r_2 is to be replaced by $r_1 + t$, where t is the thickness, and t^2 may be neglected when it is to be added to r_1^2 . The formula then reduces to $tS_1 = R_1(r_1 + t)$, which is slightly more accurate than that of (30), and it gives slightly larger values of S_1 in investigation and slightly larger thicknesses in design. Neglecting t in comparison with

r , this becomes $tS_1 = r_1R$, which is the same as the common formula for thin pipes derived in Art. 30. Either of these formulas, however, would lead to grave error when applied to a pipe whose thickness is as great as one-half its diameter.

From formula (150)' it is seen that r_2 becomes infinite when R_1 equals S , that is, the inside unit-pressure must never be greater than the allowable tensile unit-stress of the material. Cast-iron cylinders for small forging presses have been used under pressures as high as 5 000 pounds per square inch, and it hence follows that the actual unit-stress S must have been much higher than this; the thickness of such cylinders is usually greater than the inside radius. The indications of experience are that factors of safety for thick pipes under pressure may be much lower than for thin ones.

Prob. 150. A solid gun tube is 6 inches in diameter and 3 inches thick. What is the inside pressure that will produce a maximum tangential tension of 30 000 pounds per square inch?

ART. 151. A COMPOUND CYLINDER

In a solid gun the maximum tension occurs at the inside surface during the explosion, rising suddenly from 0 up to its greatest value S_1 . If now the metal near the bore can be brought into compression, this initial stress must be overcome before the tension can take effect, and thus the capacity to resist the inside pressure is increased. One method of producing this compression is by means of a hoop, or jacket, shrunk upon a tube so as to produce an outside unit-pressure R_2 over the surface of the tube. This arrangement may be called a hollow compound cylinder.

In its normal state of rest, the inner cylinder or tube has no pressure on its inner surface and R_2 on each square unit of its outside surface. Making $R_1 = 0$ in (149)' and also $x = r_1$ and $x = r_2$ in succession, there are found

$$S_1 = -R_2 \cdot 2r_2^2 / (r_2^2 - r_1^2) \quad S_2 = -R_2 \cdot (r_2^2 + r_1^2) / (r_2^2 - r_1^2)$$

which are the tangential unit-stresses at the inside and outside surfaces of the tube due to the external pressure R_2 . Both of

these are compression, but the former is numerically greater than the latter, since $2r_2^2$ is greater than $r_2^2 + r_1^2$. If the hoop is to be shrunk on so as to produce a compressive unit-stress S_e at the inner surface of the tube, the unit-pressure R_2 upon the outer surface must be,

$$R_2 = -S_e(r_2^2 - r_1^2)/2r_2^2$$

and the shrinkage may be so regulated as to produce this pressure R_2 in the normal state of rest. Then the tangential stresses throughout the tube are all compression, while the radial pressures range from R_2 on the outer surface to 0 on the inner surface.

As an example, let $r_1 = 2$ inches, $r_2 = 3$ inches, and let it be required to find the outer pressure which will cause a tangential compressive unit-stress of 18 000 pounds per square inch at the inside surface of the tube. Here the last formula gives $R_2 = 5$ 000 pounds per square inch, and hence the hoop must be shrunk upon the tube so as to produce this radial pressure at the surface of contact of hoop and tube.

When the gun is fired, the explosion of the powder causes an internal tangential tension S given by (149)', the greatest value of which is at the inside surface of the tube. Making $x = r_1$, this tensile unit-stress is found to be,

$$S_1 = [(r_1^2 + r_2^2)R_1 - 2r_2^2R_2]/(r_2^2 - r_1^2)$$

which is Lamé's formula for the investigation of the tube of a compound gun. This tension first overcomes the initial compression S_e due to shrinkage, so that the maximum tensile unit-stress at the inner surface during firing is $S_1 - S_e$. In Fig. 155 the line Aa represents the compression S_e at the inner surface of the tube before the firing, aa_1 the total tension S_1 produced during the explosion, and Aa_1 the actual tension $S_1 - S_e$ during firing. For example, if the radial pressure R_2 is made such that the tangential compression S_e is 30 000 pounds per square inch, and if the inside tensile stress-unit S_1 due to the powder explosion is 65 000 pounds per square inch, then the actual tension at the inside surface of the tube is 35 000 pounds per square inch.

For example, let a tube whose inside and outside diameters

are 4 inches and .6 inches be hooped so that a tangential compression of 18 000 pounds per square inch is caused at the bore, while the inside pressure caused by the explosion is 25 000 pounds per square inch. It is required to find the tangential stress at the bore during the explosion. Here $r_1=2$ and $r_2=3$ inches, $R_1=25\ 000$, and $R_2=5\ 000$, as seen above. Then $S_1=47\ 000$ pounds per square inch is the tension due to the explosion, but before this can take effect the initial compression of 18 000 pounds must be overcome. Hence the resultant tension at the bore during the firing is $47\ 000-18\ 000=29\ 000$ pounds per square inch. If this tube has no hoop, the tension at the inside surface, found by the method of the last article, is 57 200 pounds per square inch. The very great advantage of the hoop in diminishing the internal stresses during the firing is hence apparent.

Prob. 151. A gun tube 3 inches in diameter and 1.5 inches thick is hooped so that the tangential compression on the inside surface is 30 000 pounds per square inch. What powder pressure R_1 will produce a resultant tangential tension on the inside surface of 30 000 pounds per square inch?

ART. 152. CLAVARINO'S FORMULAS

The preceding method of investigating gun tubes is defective in that the two unit-stresses S and R are the apparent and not the true internal unit-stresses. It was shown in Art. 139 that the true stresses are those corresponding to the actual deformations, and that they are determined from the apparent stresses by help of the factor of lateral contraction λ . For gun-steel the value of λ is usually taken as $\frac{1}{3}$. Lamé's formulas were deduced in 1833, but it was not until about 1880 that they were modified by Clavarino so as to give the true internal stresses.

At any point in the annulus of a hollow cylinder (Fig. 149*b*) the apparent tangential, radial, and longitudinal unit-stresses are S , R , and S_0 . Let T be the true tangential unit-stress, then from (139) its value is $T=S-\lambda R-\lambda S_0$; inserting in this the values of S , R , and S_0 found in Art. 149, and taking the factor

of lateral contraction as $\frac{1}{3}$, it reduces to,

$$T = \left(r_1^2 R_1 - r_2^2 R_2 + \frac{4r_1^2 r_2^2}{x^2} (R_1 - R_2) \right) / 3(r_2^2 - r_1^2) \quad (152)$$

which is Clavarino's formula for the tangential unit-stress. This is the principal formula for the investigation of steel guns and thick pipes.

This formula shows, as before, that the tangential stress is greatest at the inside surface of the cylinder. Making $x = r_1$, the true internal maximum unit-stress is found to be,

$$T_1 = [(r_1^2 + 4r_2^2)R_1 - 5r_2^2 R_2] / 3(r_2^2 - r_1^2) \quad (152)'$$

which is the practical formula for the discussion of the most common cases. T_1 may be either tension or compression, depending upon the relative values of the pressures and radii.

Clavarino's formulas have been generally used since 1885 in the investigation and design of guns, instead of those of Lamé. In order to compare them, the particular case where the outer diameter is double the inner diameter may be considered. Here $r_2 = 2r_1$ and formulas (149)' and (152)' reduce to,

$$S_1 = \frac{1}{3}(5R_1 - 8R_2) \quad T_1 = \frac{1}{3}(17R_1 - 20R_2)$$

Now if $R_2 = 0$, the first formula gives a smaller unit-stress than the second; if $R_2 = R_1$, the first gives a unit-stress three times as large as the second; if $R_1 = 0$, the first gives a value somewhat larger than the second. Thus, since the second formula gives undoubtedly a better representation of the true stress than the first, it follows that Lamé's method errs on the side of danger for a solid gun and on the side of safety for a hooped tube. The value $\frac{1}{3}$ here used for the factor of lateral contraction is that employed in the United States by both the Army and the Navy in gun formulas, and also generally in Europe; in France, however, the value $\epsilon = \frac{1}{4}$ is adopted.

For a thick pipe or solid gun, the outside pressure R_2 is zero, and formula (152)' can then be written in the forms,

$$T_1 = \frac{1}{3}R_1 \frac{r_1^2 + 4r_2^2}{r_2^2 - r_1^2} \quad r_2 = r_1 \left(\frac{3T_1 + R_1}{3T_1 - 4R_1} \right)^{\frac{1}{2}} \quad (152)''$$

the first of which may be used for the investigation and the second

for the design of hollow cylinders. According to the second formula, the inside unit-pressure R_1 can never be as large as three-fourths of the allowable tensile unit-stress T_1 , and this may be taken higher than for a thin pipe. For example, let it be required to find the thickness of a steel pipe 8 inches in inside diameter, under a head of water of 1200 feet, this including the effect of water ram (Treatise on Hydraulics, Art. 148), the allowable tensile unit-stress to be 15000 pounds per square inch. Here $T_1 = 15000$, and $R_1 = 0.434 \times 1200 = 520$ pounds per square inch, and then the formula gives $r_2 = 4.18$ inches, whence the required thickness is 0.18 inches. From the old formula (150)', the thickness is found to be 0.22 inches.

Prob. 152. Solve Problem 150 by the formulas of this article and compare the results found by the two methods.

ART. 153. BIRNIE'S FORMULAS

The preceding articles present an outline of the methods of investigating stresses in guns by the formulas of Lamé and Clavarino. The formulas of Lamé refer to apparent stresses only; those of Clavarino, although referring to true stresses, are not strictly correct for hooped guns at rest because they are deduced for a hollow cylinder with closed ends. Now a gun at rest has no inside pressure and no closed end and hence there can be no external longitudinal stress upon it; accordingly the unit-stress S_0 should be zero for a gun at rest. The true tangential unit-stress T then is $S - \frac{1}{3}R$; using the values of S and R deduced in Art. 149, there results for any point in the annulus, at a distance x from the axis,

$$T = \left(2r_1^2 R_1 - 2r_2^2 R_2 + \frac{4r_1^2 r_2^2}{x^2} (R_1 - R_2) \right) / 3(r_2^2 - r_1^2) \quad (153)$$

which is Birnie's principal formula for the discussion of hooped guns at rest. Making $x = r_1$, this becomes,

$$T_1 = [(2r_1^2 + 4r_2^2)R_1 - 6r_2^2 R_2] / 3(r_2^2 - r_1^2) \quad (153)'$$

which is the tangential unit-stress at the inside surface of a hoop

with the radii r_1 and r_2 and is under the pressures R_1 and R_2 . For the gun tube itself, R_1 is 0 during the state of rest.

Birnie's formulas are used in the ordnance bureau of the United States Army for the discussion of gun tubes and hoops, both at rest and during the firing. To compare the formulas of Clavarino with those of Birnie, the particular case of a hoop or pipe where $r_2 = 1.2r_1$ may be considered. Then (152)' and (153)' reduce to,

$$T_1 = 5.12R_1 - 5.56R_2 \quad \text{and} \quad T_1 = 5.88R_1 - 6.35R_2$$

Now if $R_2 = 0$, as for a solid gun during firing, the second formula gives a tangential unit-stress 15 percent larger than the first; if $R_1 = 0$, as for a hooped gun at rest, the second gives a unit stress 18 percent larger than the first. Thus for this case Clavarino's formulas appear to err toward the side of danger.

Birnie's formulas apply only to hoops and tubes upon which the longitudinal stress is zero, and this is not the case during the explosion. For a solid gun, or for a tube attached to the breech block, a more correct formula may be found by considering the actual value of S_0 due to the inside pressure. Here the longitudinal pressure is $\pi r_1^2 R_1$, and this produces longitudinal tension upon the area $\pi(r_2^2 - r_1^2)$, so that $S_0 = r_1^2 R_1 / (r_2^2 - r_1^2)$ is the apparent longitudinal unit-stress. The true tangential stress T at any point in the annulus then is $S - \frac{1}{3}R - \frac{1}{3}S_0$, and accordingly,

$$T = \left(r_1^2 R_1 - 2r_2^2 R_2 + \frac{4r_1^2 r_2^2}{x^2} (R_1 - R_2) \right) / 3(r_2^2 - r_1^2)$$

This gives values of T lower than those found from the formulas of Clavarino and Birnie. For $x = r_1$ it becomes,

$$T_1 = [(r_1^2 + 4r_2^2)R_1 - 6r_2^2 R_2] / 3(r_2^2 - r_1^2)$$

which is the true tangential unit-stress at the inside surface of a hooped gun during the explosion, R_2 being the pressure upon its outside surface due to the shrinkage of the hoop. For a simple gun tube or water pipe where $R_2 = 0$, this formula agrees with that of Clavarino; for a hooped tube at rest, it gives a value of T_1 which is 20 percent greater than that of Clavarino.

Prob. 153. Solve Problem 150 by the formulas of this article and compare the results with those of Problem 152.

ART. 154. HOOP SHRINKAGE

Let e be the elongation or contraction of any radius x , then $2\pi e$ is the elongation or contraction of any circumference $2\pi x$. Now $2\pi e/2\pi x$ is the change in the circumference per unit of length due to the unit-stress T ; hence $e/x = T/E$, and $e = (T/E)x$ is the change in length of the radius of the circle due to the tangential unit-stress T . When $x = r_1$, the deformation e_1 is that of the radius of the bore due to the unit-stress T_1 ; if $x = r_2$, the deformation e_2 is that of the outside radius where the unit-stress is T_2 .

Suppose a compound cylinder to be formed by shrinking a hoop upon a tube. The inside radius of the tube is r_1 and its outside radius r_2 ; the inside radius of the hoop is r_2 and its outside radius r_3 . In consequence of the shrinkage the radial unit-pressure R_2 is produced between the two surfaces; this causes the tube to be under tangential compression and the hoop to be under tangential tension. It is required to find these stresses when the original inside radius of the hoop is less than that of the outside radius of the tube by the amount e .

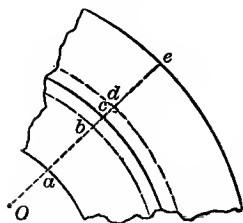

Fig. 154

Let e_2 be the decrease in the outside radius of the tube and e_2' the increase in the inside radius of the hoop; then $e = e_2 + e_2'$. In Fig. 154, which is much exaggerated, cd represents e_2 and bc represents e_2' . Also, let T_2 be the tangential compression at the outside surface of the tube due to the shortening e_2 , and let T_2' be the tangential tension at the inside surface of the hoop due to the elongation e_2' . Then

$$e = (T_2/E)r_2 + (T_2'/E)r_2 \quad \text{or} \quad T_2 + T_2' = Ee/r_2$$

which gives one equation between T_2 and T_2' .

Formula (153)' is applied to the tube by making $R_1 = 0$ and

$x=r_2$; thus the tangential compression is,

$$T_2 = R_2(4r_1^2 + 2r_2^2)/3(r_2^2 - r_1^2) = \alpha R_2$$

Formula (153) is applied to the hoop by replacing R_1 by R_2 , R_2 by 0, r_1 by r_2 , and r_2 by r_3 ; then for $x=r_2$, there results,

$$T_2' = R_2(2r_2^2 + 4r_3^2)/3(r_3^2 - r_2^2) = \beta R_2$$

which is the tangential tension. Dividing the first of these expressions by the second, there is found,

$$T_2/T_2' = \alpha/\beta \quad \text{or} \quad \beta T_2 = \alpha T_2'$$

which is a second equation between T_2 and T_2' .

The solution of these two equations furnishes the values of T_2 and T_2' in terms of known quantities; then,

$$T_2 = \frac{Ee}{r_2} \cdot \frac{\alpha}{\alpha + \beta} \quad T_2' = \frac{Ee}{r_2} \cdot \frac{\beta}{\alpha + \beta} \quad (154)$$

in which α and β depend only on the radii, or,

$$\alpha = \frac{2}{3}(2r_1^2 + r_2^2)/(r_2^2 - r_1^2) \quad \beta = \frac{2}{3}(r_2^2 + 2r_3^2)/(r_3^2 - r_2^2)$$

and thus the tangential compression at the outside surface of the tube and the tangential tension at the inside surface of the hoop may be computed. The tangential compression at the bore is, however, greater than T_2 , and it may be found from (153) by substituting the value of R_2 , now known, and making $x=r_1$; thus,

$$T_1 = T_2 \cdot 3r_2^2/(2r_1^2 + r_2^2)$$

is the greatest compressive unit-stress in the tube due to the radial pressure of the hoop.

As a numerical example, let a compound cylinder be formed of a steel tube whose inside radius is 3 inches and outside radius 5 inches, with a steel hoop whose thickness is 2 inches. It is required to find the stresses produced when the original difference between the outside radius of the tube and the inside radius of the hoop is 0.004 inches. First, the sum of the two tangential stresses at the surface of contact is $(Ee)/r_2 = 24,000$ pounds per square inch, if E is taken as 30,000,000 pounds per square inch. Secondly, from the given radii, the value of α is found to be $43/24$, and that of β to be $41/12$. Then formulas (154) give $T_2 = 8,260$ pounds per square inch at the outside surface of the

tube and $T_2' = 15\ 740$ pounds per square inch for the inside surface of the hoop. Thus it is seen that the hoop tension is nearly double the compression on the outside surface of the tube. At the bore of the tube, however, the tangential compression is found to be $T_1 = 14\ 400$ pounds per square inch.

The decrease in the outside radius of the tube is next computed and found to be $e_2 = 0.00138$ inches, while the increase in the inside radius of the hoop is $e_2' = 0.00262$ inches. Hence if the radius of the common surface of contact is to be exactly $\frac{5}{8}$ inches after the shrinkage, the tube should be turned to an outside radius of 5.0014 inches, and the hoop to an inside radius of 4.9974 inches. The radius of the bore, however, will then be less than 3 inches by the quantity $(T_1 r_1 / E) = 0.00144$ inches; hence if its final diameter is to be exactly 6.0000 inches, it should be turned to a diameter of 6.0029 inches.

The formula of Birnie has been used in solving the above numerical example; if that of Clavarino is used, the following values will be found: $T_2 = 7\ 030$, $T_2' = 16\ 970$, $T_1 = 14\ 400$ pounds per square inch; $e_2 = 0.00117$, $e_2' = 0.00283$, and $e_1 = 0.00144$ inches. The shrinkages thus agree within 0.0002 , which is as close as measurements can be relied upon.

The above investigation closely applies to the case of a hoop or crank web shrunk upon a solid shaft or solid crank pin (Art. 97) by making $r_1 = 0$ and letting r_2 be the mean radius of the web. For example, let $r_1 = 0$, $r_2 = 16$ inches, $r_3 = 24$ inches, and let e/r_2 be $\frac{1}{1500}$ in accordance with the old rule (Art. 32). Then $\alpha = \frac{2}{3}$, $\beta = \frac{2}{3} \times 4.4$, and the tangential compression at the outside surface of the shaft or pin is $T_2 = 3\ 740$ pounds per square inch, while the tangential tension at the surface of the hoop or web is $T_2' = 16\ 500$ pounds per square inch; the radial compression in the crank or pin is $T_1 = 11\ 300$ pounds per square inch. It thus appears that the ratio $e/r_2 = \frac{1}{1500}$ gives shrinkage stresses which are higher than advisable when the other stresses which act upon the web and pin are considered (Art. 98).

Prob. 154. A solid steel shaft, 6 inches in radius, is to be hooped so that the greatest tensile stress in the hoop and the greatest com-

pressive stress in the shaft shall be 15 000 pounds per square inch. Find the thickness of the hoop and the radius to which its inside surface should be turned.

ART. 155. DESIGN OF HOOPED GUNS

A hooped gun should be so constructed that neither the stresses due to hoop shrinkage nor those developed during the firing shall exceed the elastic limit of the material. The simple case of a tube with one hoop can here only be considered. If the radii are given, as also the inner pressure R_1 due to the explosion, it may be desired to find the shrinkages so that this requirement will be fulfilled. As R_1 is very large, it is desirable that the given dimensions should be such as to require the least amount of material.

The condition of minimum amount of material will be in general fulfilled when the stresses during the explosion are as great as allowable and as nearly equal as possible. The diagram in Fig. 155 represents the distribution of the internal stresses under this supposition. O is the center of the gun, OA the inside radius r_1 , while AB is the thickness of the tube and BC that of the hoop. The shaded areas show the stresses due to hoop shrinkage, Aa and Bb being the tangential compressions T_1 and T_2 of the last article, while Bb' is the tangential tension T_2' , and Cc is the tangential tension at the outer surface of the hoop. When the explosion occurs the two cylinders are thrown into tangential tension, Aa_1 and Bb_1 being those at the inner surfaces of the tube and hoop. The above principle indicates that both Aa_1 and Bb_1 should be equal to the maximum allowable unit-stress T_e , which for guns is often taken nearly as high as the elastic limit of the material.

In designing a hooped gun, the radius of the bore and the thickness of the tube may be assumed, and it may be required to find the thickness and shrinkage of the hoop so that the stresses Aa , Aa_1 , and Bb_1 in Fig. 155 are each equal to the elastic limit of the material. Or, given the radius of the bore and the out-

side radius of the hoop, it may be required to find the intermediate radius under the same conditions. These problems can be solved, as well as more complex ones relating to guns with several hoops. Guns with seven hoops have been built, but the usual number is three or four.

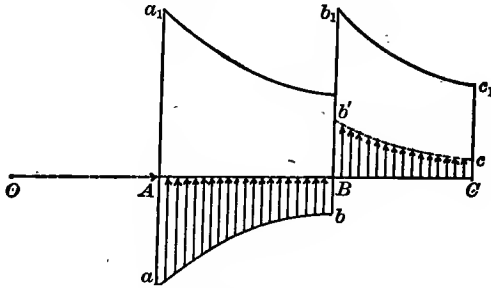

Fig. 155

The formulas of Arts. 153 and 154 may be applied to the design of a gun by assuming the allowable tangential unit-stresses, as also the thicknesses of the tube and hoops. For a given unit-pressure R_1 due to the explosion, the shrinkages are then to be computed. This method is one frequently used, and it will here be illustrated for a gun with one hoop. Let $r_1 = 3.04$, $r_2 = 5.80$, and $r_3 = 9.75$ be the given radii, and let 50 000 pounds per square inch be the allowable unit-stress for both tension and compression. It is required to find the radii to which the surfaces shall be turned so that their values shall be those above given when the gun is at rest. These radii will be readily found when the tangential unit-stresses T_1 and T_2 for the tube and T'_2 and T_3 for the hoop have been computed, since these determine the changes in length of the radii. The first step is to compute the numbers α and β , which are found to be 1.424 and 2.425 respectively. Since T_1 is to be 50 000 pounds per square inch compression for the inside surface of the tube, T_2 for the outer surface will be $T_1(2r_1^2 + r_2^2)/3r_2^2 = 25\,800$ pounds per square inch compression, and accordingly for the common surface of tube and hoop $R_2 = T_2/\alpha = 18\,100$ pounds per square inch. For the inside surface of the hoop, $T'_2 = \beta R_2 = 43\,900$ pounds per square inch tension. For the outside surface of the

hoop where $R_3 = 0$, formula (153) may be used by increasing each of the subscripts by unity and making $x = r_3$, thus giving $T_3 = 2R_2 r_2^2 / (r_3^2 - r_2^2) = 19\ 800$ pounds per square inch tension. Then the change in the inside radius of the gun tube is $(T_1/E)r_1 = 0.0051$ inches, and hence the bore must be turned to a radius of $3.0400 + 0.0051 = 3.0451$ inches in order that it may be exactly 3.04 inches after the hoop is shrunk on; the change in the outside radius is $(T_2/E)r_2 = 0.0050$ inches, so that the outside surface of the tube must be turned to a radius of $5.800 + 0.0050 = 5.8050$ inches. The change in the inside radius of the hoop is $(T'_2/E)r_2 = 0.0085$ inches, so that its inner surface must be turned to a radius of $5.8000 - 0.0085 = 5.7915$ inches; the change in the outside radius of the hoop is $(T_3/E)r_3 = 0.0064$ inches, so that its outside surface must be turned to a radius of $9.7500 - 0.0064 = 9.7436$ inches.

This gun must now be investigated to find what powder pressure will cause the stresses T_1 and T'_2 to be 50 000 pounds per square inch tension during the explosion. If T'_2 has this value, the part of it due to the powder explosion is $50\ 000 - 43\ 900 = 6\ 100$ pounds per square inch; hence the radial compression between the tube and the hoop which is due to the explosion must be $R_2 = 6\ 100/\beta = 2\ 500$ pounds per square inch. The value of T_1 due to the explosion is 100 000 pounds per square inch tension, since the initial compression of 50 000 pounds per square inch must first be overcome. Inserting then in (153)' the values $T_1 = 100\ 000$, $R_2 = 2\ 500$, $r_1^2 = 9.242$, $r_2^2 = 33.640$, and solving for R_1 gives $R_1 = 51\ 100$ pounds per square inch, which is the highest allowable powder pressure. Under this pressure the unit-stresses represented by Aa , Aa_1 , and Bb_1 in Fig. 155 are each 50 000 pounds per square inch, while all other tangential and radial stresses have smaller values.

In conclusion it may be noted that this chapter has been prepared in order to present the general principles of the design of guns, rather than to give the detailed methods which are followed when three or more hoops are used. The work of Meigs and Ingersoll (Baltimore, 1885) and that of Story (Fort

Monroe, 1894), each being entitled *The Elastic Strength of Guns*, may be consulted for detailed discussions. The former gives the methods and formulas for navy guns, while the latter gives those for army guns; these differ mainly in that the Navy employs the formulas of Clavarino, while the Army uses those of Birnie.

Prob. 155*a*. Prove that a gun tube with one hoop is most advantageously designed when the common radius of tube and hoop is a mean proportional between the other two radii.

Prob. 155*b*. Discuss a gun with two hoops where $r_1 = 3.50$, $r_2 = 9.15$, $r_3 = 11.25$, $r_4 = 12.25$ inches and which is to be under a powder pressure of 50 000 pounds per square inch. Find a set of shrinkages so that the compressive stress at the bore when the gun is at rest shall be 45 000 pounds per square inch; and so that the tensile stresses at the bore and at the inside of each hoop during the explosion shall be 40 000 pounds per square inch.

CHAPTER XVII

ROLLERS, PLATES, SPHERES

ART. 156. CYLINDRICAL ROLLERS

Let cylindrical rollers of diameter d and length l be placed between two flat plates and transfer a load from the upper to the lower plate. Fig. 156a shows end and side views of the two plates with one roller which carries the load W . It was found in the experiments of Bach that the plates were but little deformed in comparison with the roller, and hence the entire defor-

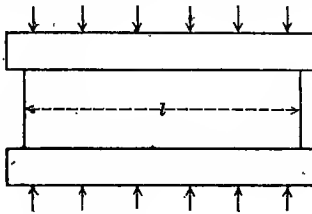
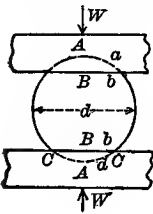

Fig. 156a

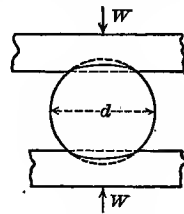

Fig. 156b

mation will here be regarded as confined to the latter. The vertical diameter AA is shortened to BB and any vertical chord aa is shortened to bb . The change of length in the vertical radius is AB and that in the vertical half-chord is ab . The unit-shortening of the vertical radius is $AB/\frac{1}{2}AA$ and that of the vertical half-chord is $ab/\frac{1}{2}aa$ and the compressive unit-stresses are proportional to these unit-shortenings (Art. 10). Let the greater shortening AB be called e and the shortening ab be called y ; and let the compressive unit-stresses at B and b be called S and S_y . Then, if the elastic limit of the material is not exceeded, $S/S_y = e/y$ or $S_y = S \cdot y/e$. The unit-stress S is evidently the maximum and it is required to determine its value in terms of W , d , and l .

The value of S may be expressed by noting that $e/\frac{1}{2}d$ is the unit-shortening of the vertical radius, and that this is equal to

S/E , where E is the modulus of elasticity (Art. 9); hence $S/E = e/\frac{1}{2}d$. The sum of the vertical stresses in each cylindrical segment must equal the total load W , since it holds that load in equilibrium. Let x be the distance Bb ; then the unit-stress S_y acts over the area $l\delta x$, and hence the sum of all the vertical stresses $S_y \cdot l\delta x$ equals W . Accordingly,

$$S/E = e/\frac{1}{2}d \quad \text{and} \quad \int S_y \cdot l\delta x = W$$

are two equations for determining the values of S and e .

To solve these equations, S_y is to be replaced by its value $S \cdot y/e$ and the second equation then becomes $Sl \int y\delta x = We$. Now $\int y\delta x$ is the area of the circular segment $CACBC$; but, since the deformation is very slight, the arc CAC may be regarded as parabolic or the area of the segment as $\frac{2}{3}CC \times AB$. Now $AB = e$ and $\frac{1}{2}CC = BC = (ed - e^2)^{\frac{1}{2}} = (ed)^{\frac{1}{2}}$ nearly. The solution of the two equations then leads to the formula,

$$S = \left(\frac{9W^2E}{8l^2d^2} \right)^{\frac{1}{3}} \quad \text{or} \quad ld = \frac{3W}{2S} \left(\frac{E}{2S} \right)^{\frac{1}{3}} \quad (156)$$

the first of which may be used for computing the unit-stress S when the load and the dimensions of the roller are given, while the second may be used for determining the size of a roller to carry a given load under an assigned unit-stress.

Let w be the load per unit of length of the roller, or $w = W/l$, then the formula (156) may be written,

$$W = \frac{2}{3}ldS(2S/E)^{\frac{1}{3}} \quad \text{or} \quad w = \frac{2}{3}dS(2S/E)^{\frac{1}{3}} \quad (156)'$$

which shows that the load on a cylindrical roller should vary directly as its diameter. Taking $S = 15\,000$ and $E = 30\,000\,000$ pounds per square inch for steel, the last formula reduces to $w = 315d$. This agrees well with the rule for bridge rollers given in Cooper's Specifications of 1901, which is $w = 300d$. The erroneous rule, $w = 1\,200\sqrt{d}$, which requires the load to vary as the square root of the diameter, is still to be found in some bridge specifications.

As a numerical example, let it be required to find the factor of safety of six wooden rollers used in moving a large block of stone which weighs 12 000 pounds, the diameter of each roller being 6 inches and its length 8 feet 4 inches. Here $W = \frac{1}{6} \times 12\ 000 = 2\ 000$ pounds, $E = 1\ 500\ 000$ pounds per square inch, $l = 100$ inches, and $d = 6$ inches; then formula (156) gives $S = 266$ pounds per square inch, and hence the factor of safety is $8\ 000/266 = 30$, which indicates a high degree of security. Again, let it be required to find the diameter of a cast-iron roller which is 6 feet long in order to carry 30 000 pounds with a factor of safety of 18. Here $W = 30\ 000$ pounds, $S = 90\ 000/18 = 5\ 000$ pounds per square inch, $E = 15\ 000\ 000$ pounds per square inch, and $l = 72$ inches; then in the formula everything is known except d and the solution gives $d = 4.6$ inches.

The assumption that the plates are not deformed at the surface of contact with the roller is one that is not universally accepted. Later experiments by Juselius appear to indicate, for rollers and plates of the same material, that the deformation of the two plates in any vertical is about equal to that of the same vertical in the roller. By using this conclusion, as indicated in Fig. 156*b*, the above reasoning and formulas will be modified. The shortening of the vertical radius will now be one-half of its former value, and thus the first formulas of (156) and (156)' become,

$$S = (9W^2E/16l^2d^2)^{\frac{1}{2}} \quad W = \frac{4}{3}ldS(S/E)^{\frac{1}{2}}$$

Accordingly the compressive unit-stress due to a given load is 21 percent less than before, while the load that may be carried with a given unit-stress is 41 percent greater than before. Applying this second formula to the cast-iron roller of the last paragraph, its diameter is found to be $d = 3.4$ inches. It is seen, therefore, that the assumption used at the beginning of this article errs on the side of safety when the plates are actually deformed.

Prob. 156. A load of 192 000 pounds is carried on cylindrical steel rollers 16 inches long and 3 inches diameter. Compute the number of rollers needed when the allowable unit-stress is 12 000 pounds per square inch, using the formula which appears to be most safe.

ART. 157. SPHERICAL ROLLERS

Let a sphere of diameter d be placed between two plates and be subject to compression by a load W . The left-hand diagram of Fig. 156*a* may represent a vertical section of the sphere and plates, the former being regarded as alone deformed. The vertical diameter AA is shortened to BB and any vertical line aa is shortened to bb . Let S and S_y be the compressive unit-stresses in the vertical lines AA and aa ; let the greatest shortening AB be called e , and the shortening ab be called y . Then, for stresses within the elastic limit, $S/S_y = e/y$. The unit-stress S is the greatest and it is required to find its value in terms of W and d .

As $e/\frac{1}{2}d$ is the unit-change in length of the vertical radius, the value of S may be expressed by $S/E = e/\frac{1}{2}d$ (Art. 10) and this is one equation between S and e . To find another equation, the sum of the vertical stresses in the spherical segment must equal the load W . Let x be the distance Bb ; then the unit-stress S_y acts over the area $2\pi x \cdot \delta x$, and hence the sum of all the vertical stresses $S_y \cdot 2\pi x \delta x$ equals W . Accordingly,

$$S/E = e/\frac{1}{2}d \quad 2\pi \int S_y \cdot x \delta x = W$$

are two equations for determining the values of S and e .

To solve these equations, S_y is to be replaced by its value $S \cdot y/e$ and the second equation then becomes $S \int 2\pi y x \delta x = We$. Now $\int 2\pi y x \delta x$ is the volume of the spherical segment whose section is $CACBC$ in the figure; but, since the deformation is very slight, the arc CAC may be regarded as parabolic, and then the volume is one-half that of a cylinder having the radius BC and the altitude AB . Now $AB = e$, and $BC = (ed - e^2)^{\frac{1}{2}} = (ed)^{\frac{1}{2}}$, very nearly, since e is small compared with d . Accordingly the value of the integral is $\frac{1}{2}\pi e^2 d$, and then $\frac{1}{2}\pi S e d = W$. Inserting in this the value of e from the first equation, it reduces to,

$$S^2 = WE/\frac{1}{4}\pi d^2 \quad \text{or} \quad W = \frac{1}{4}\pi d^2 S^2/E \quad (157)$$

From the first formula S may be computed when W is given, and from the second W may be computed when S is given. The diameter required for a sphere to carry a given load with an allow-

able unit-stress is found from $d^2 = 4WE/\pi S^2$; thus diameters of spherical rollers should vary as the square roots of their loads.

In strictness there is always some deformation of the plates as well as of the spheres, and the old assumption that the total deformation is equally divided is probably nearer the truth than that it is all confined to the sphere. Under this assumption AB is to be taken as $\frac{1}{2}e$ and then the formulas become,

$$S^2 = WE/\frac{1}{2}\pi d^2, \quad W = \frac{1}{2}\pi d^2 S^2/E, \quad d^2 = 2WE/\pi S^2 \quad (157)'$$

Comparing these with the previous formulas it is seen that (157) give values of S which are 41 percent higher than (157)', values of W which are only one-half as large, and values of d which are 41 percent larger. The common formulas (157) hence err on the side of safety, and the truth probably lies between them and (157)'. When the plates are harder than the rollers, (157) is more nearly correct; when they are of equal hardness, perhaps (157)' gives the more accurate results.

These formulas, like those of the last articles, are valid only when the load produces a unit-stress S which is less than the elastic limit of the material. For stresses beyond the elastic limit, the formulas $W = C_1 ld$ for cylinders and $W = C_2 d^2$ may be considered as approximate, in which C_1 and C_2 are to be determined by experiment for each material. The experiments of Crandall and Marston on steel cylindrical rollers, which ranged in diameter from 1 inch to 16 inches, show that their crushing loads are closely given by the formula $W = 88old$, where W is in pounds and l and d in inches.

Prob. 157. How many steel spheres are required to carry a load of 6 000 pounds, with a working stress of 15 000 pounds per square inch, when they are 4 inches in diameter? How many are required when they are 12 inches in diameter?

ART. 158. CONTACT OF CONCENTRATED LOADS

When a concentrated load is placed upon a horizontal beam or plate, it produces compressive stresses over a certain area. In bridges and buildings concentrated loads are often applied to

the upper surface of a beam by means of another beam at right angles to it; in this case the surface of contact is plane and the concentrated load W may be regarded as uniformly distributed over the area. This subject has already been mentioned in Art. 142, and it is there indicated that, for simple beams, the flexural compressive stress and the direct compressive stress due to the concentrated load combine to produce a true compressive stress which is smaller than either of them. When the concentrated load rests upon the lower flange of a simple I beam, as sometimes occurs in practice, the combination of the direct compression with the flexural tension produces a true compression and a true tension which are larger than the apparent ones. It is hence always preferable to support the concentrated load on the compressive side of a beam.

The two preceding articles contain examples of the contact of cylinders and spheres with plane surfaces, and from the reasoning there given a relation may be deduced between the area of contact and the load W . For the cylinder the area of contact is the width $2(ed)^{\frac{1}{2}}$ multiplied by the length l ; inserting the value of e , this area is $a = 2ld(S/2E)^{\frac{1}{2}}$, and replacing S by its value in terms of W , it becomes $a = (ld)^{\frac{1}{2}}(3W/E)^{\frac{1}{2}}$. The area of contact hence varies as the cube root of the load for the same cylindrical roller; thus if a load W_1 gives an area of contact a_1 , a load $8W_1$ is required in order to make the area $2a_1$. This conclusion is valid only when the elastic limit of the material is not exceeded. The formula here deduced for a is for the case where the plate is not deformed; when the deformation is equally divided between the plate and the roller, $3W$ is to be replaced by $6W$, and the law connecting a and W remains unaltered.

For the case of a sphere resting on a plane, Art. 157 shows that the area of contact is πed ; placing in this the value of e in terms of S , and then that of S in terms of W , there is found $a = d(\pi W/E)^{\frac{1}{2}}$, which shows that the area of contact varies as the diameter of the sphere and with the square root of the load. To double the area of contact, it is hence necessary to quadruple the load upon a sphere; this law holds whether the sphere

alone be deformed or whether the deformation is divided between the sphere and plate. The above law does not agree with the conclusions derived from the experiments made by J. B. Johnson on the contact between car-wheels and railroad rails (Art. 142). This disagreement is probably mostly due to the fact that the upper surface of the rail is not a plane, and in part to the fact that the unit-stresses were very high.

Prob. 158. Compute the total area of contact for the cylindrical rollers of Problem 156. If the same load is carried on spherical steel rollers 3 inches in diameter, compute the total area of contact.

ART. 159. CIRCULAR PLATES WITH UNIFORM LOAD

Let a circular plate of radius r and uniform thickness d be subject on one side to a pressure R on each square unit of area, and be supported or fixed around the circumference. The head of a cylinder under the pressure of water or steam is a circular plate in such a condition. Under the action of the load, the plate bends, the side in contact with the load being subject to compression while the other side is under tension; the maximum stress caused by the flexure will evidently occur at the middle, and this is required to be determined.

As the simplest case let the plate be merely supported around the circumference. The total load on the plate being $\pi r^2 R$, the total reaction of the support is also $\pi r^2 R$, or the reaction per linear unit is $\frac{1}{2} r R$. Now let a strip having the small width b be imagined to be cut out of the plate, so that its central line coincides with a diameter. The reaction at each end of this strip is $b \cdot \frac{1}{2} r R$ and the load on the strip is $b \cdot 2rR$. The sum of the two reactions being only one-half the load, an upward shearing force equal to brR must act along the sides of the strip to maintain the equilibrium. At the center of the circle there can be no shearing stress, and the most probable assumption regarding its distribution on the sides of the strip is to take

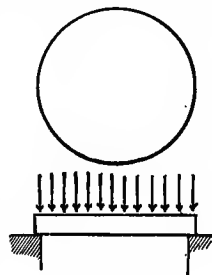

Fig. 159.

it as constant from the center to the circumference so that it acts like an upward uniform load.

The strip of breadth b , depth d , and length $2r$ is thus a simple beam acted upon by two vertical reactions, each equal to $\frac{1}{2}brR$, a downward uniform load $2brR$, and two vertical shears on the sides, each equal to $\frac{1}{2}brR$. The bending moment at the middle of this imaginary beam hence is,

$$M = \frac{1}{2}brR \cdot r + \frac{1}{2}brR \cdot \frac{1}{2}r - brR \cdot \frac{1}{2}r = \frac{1}{4}br^2R$$

and the maximum unit-stress on the upper or lower fiber at the middle of the strip is, from the flexure formula (41),

$$S = Mc/I = 6M/bd^2 = \frac{3}{2}R \cdot r^2/d^2$$

This value of S is not the real horizontal unit-stress at the center of the circle, but only the apparent stress due to considering the elementary strip. At the center the horizontal unit-stresses are acting in all directions. If a second strip is passed in Fig. 159 at right angles to the first, a unit-stress S equal in value but normal in direction to the first will be found. The true horizontal unit-stress T will be determined from the principle of Art. 139, taking into account the factor of lateral contraction λ ; on the upper side of the plate $T = S - \lambda S - \lambda R$, and on the lower side of the plate $T = S - \lambda S$. The latter value is the one to be used, since it is larger than the former. Accordingly,

$$T = \frac{3}{2}(1 - \lambda)R \cdot (r/d)^2 \quad \text{and} \quad (d/r)^2 = \frac{3}{2}(1 - \lambda)R/T$$

are the general formulas for the discussion of circular plates supported around the circumference and subject to a uniform load $\pi r^2 R$.

For cast iron the mean value of the factor of lateral contraction λ is $\frac{1}{4}$, while for wrought iron and steel it is $\frac{1}{3}$. Hence,

$$T = \frac{9}{8}(r/d)^2 R \quad \text{and} \quad T = (r/d)^2 R \quad (159)$$

are the practical formulas for use, the first applying to cast iron and the second to wrought iron and steel circular plates when supported at the circumference, T being the allowable unit-stress in tension. The unit-pressure R that a circular plate can carry varies directly as the square of its thickness and inversely as the square of its diameter.

The more common case of a circular plate fixed around its circumference cannot be solved without a discussion of the elastic curve into which a diameter deflects. The investigation is too lengthy to be given here, but it can be said that the true effective unit-stress is about two-thirds of that for the supported plate. Hence

$$T = \frac{3}{4}(r/d)^2 R \quad \text{and} \quad T = \frac{2}{3}(r/d)R \quad (159)'$$

are formulas for fixed plates, the first being for cast iron and the second for wrought iron and steel.

From the above formulas the proper thickness d for circular plates under uniform pressure may be readily computed. For example, let a fixed cast-iron cylinder head of 36 inches diameter be required to carry a uniform pressure R of 250 pounds per square inch, with an allowable tensile stress T of 3 600 pounds per square inch; then $d = r(3R/4T)^{\frac{1}{2}} = 4.1$ inches. The thickness of a steel cylinder head for the same diameter and pressure, for a tensile stress of 12 000 pounds per square inch, will be $d = r(2R/3T)^{\frac{1}{2}} = 2.1$ inches.

Prob. 159*a*. When the total load W for a circular plate is given, show that the thickness of the plate should be the same whatever be the diameter.

Prob. 159*b*. If a plate 36 inches in diameter and 2 inches thick can safely carry a pressure of 250 pounds per square inch, what is the safe pressure for a plate 24 inches in diameter and 1 inch thick?

ART. 160. CIRCULAR PLATES WITH CONCENTRATED LOAD

When a circular plate is under flexure from a concentrated load at the middle, it is more highly stressed than when the same load is uniformly distributed, as is evident from the theory of beams. The simplest case is where the plate is merely supported along its circumference and where the load P is uniformly distributed over a circle of radius r_0 , the radius of the plate being r and its thickness d . Let x be any radius less than r_0 ; the load on the circle of radius x is uniformly distributed, the load per square unit being $P/\pi r_0^2$, which may be called R . The load on the circle of radius x is $\pi x^2 R$, which acts along the section of

circumference $2\pi x$ and depth d , so that the shear per linear unit along this circumference is $-\pi x^2 R/2\pi x$ or $-\frac{1}{2}Rx$, and the shear for any distance b along this circumference is $V = -\frac{1}{2}bRx$. Since the shear V and bending moment M for any section are connected by the relation $\delta M/\delta x = V$, it follows that

$$M = -\frac{1}{4}bRx^2 + C \quad \text{or} \quad M = \frac{1}{2}bR(r_0^2 - x^2) + M_1$$

where the constant of integration is determined by the condition that M becomes M_1 , the moment for the circumference $2\pi r_0$, when x is equal to r_0 .

To find the value of M_1 , let z be any radius greater than r_0 and less than r . The total shear along the circumference $2\pi z$ is $-P$, the shear per linear unit is $-P/2\pi z$, and the shear for a distance b is $V = -Pb/2\pi z$. The bending moment M' is then found by the same relation as before to be

$$M' = -\frac{Pb}{2\pi} \log z + C \quad \text{or} \quad M' = \frac{Pb}{2\pi} \log \frac{r}{z}$$

where the constant of integration is determined by the condition that $M' = 0$ when $z = r$. Making $z = r_0$, the value of M_1 now is $(Pb/2\pi) \log r/r_0$. Inserting this in the above expression for M , replacing R by its value $P/\pi r_0$, and making $x = 0$, there results

$$M = \frac{Pb}{2\pi} \left(\frac{1}{2} + \log \frac{r}{r_0} \right)$$

as the apparent bending moment for the middle of a strip of breadth b , depth d , and length $2r$. The apparent flexural unit-stress on the upper or lower side of the middle of this strip is now found to be

$$S = \frac{6M}{bd^2} = \frac{3P}{\pi d^2} \left(\frac{1}{2} + \log \frac{r}{r_0} \right).$$

If a second strip be passed at right angles to the first, the same unit-stress S will be found acting normally to the other. The true horizontal unit-stress T on the lower side of the plate then is $T = S - \lambda S$, where λ is the factor of lateral contraction. Hence

$$T = (1 - \lambda) \left(\frac{3}{2} + 3 \log \frac{r}{r_0} \right) \frac{P}{\pi d^2} \quad (160)$$

is the general formula for the discussion of supported circular plates under concentrated loads at the middle, λ being $\frac{1}{4}$ for cast iron and $\frac{1}{3}$ for wrought iron and steel.

When the load is uniformly distributed over the entire plate, r_0 equals r , P is $\pi r^2 R$, and the formula becomes $T = \frac{3}{2}(1 - \lambda)r^2/d^2$, which is the same as deduced by another method in the last article. When $r_0 = 0$ the load is concentrated at a mathematical point and T becomes infinite. The formula can also be written

$$T = (1 - \lambda) \left(\frac{3}{2} + 3 \log \frac{r}{r_0} \right) R \frac{r_0^2}{d^2} \quad (160)'$$

in which R is the unit-pressure on the area πr_0^2 ; in cases of design the allowable unit-pressure R should not be allowed to exceed the elastic limit of the material.

As an example, let a load of 5 000 pounds be at the middle of a steel plate, distributed over a circle 1 inch in diameter, the plate being 1 inch thick and 48 inches in diameter. Here $\lambda = \frac{1}{3}$, $r_0 = \frac{1}{2}$ inch, $r = 24$ inches, and $R = 6\,360$ pounds per square inch; using a table of Napierian logarithms, $\log 48$ is found to be 3.871 and then formula (160)' gives $T = 13\,900$ pounds per square inch, which is not too high a value for a steady load.

When a plate is fixed around its circumference it is probable that the constants in the above formulas for T should be 1 instead of $\frac{3}{2}$ and 2 instead of 3. Fixing the circumference increases the strength of the plate, for the same reason that the strength of a beam is increased by fixing its ends, and a fixed plate can carry a load about fifty percent greater than that carried by a supported one. When a plate is stiffened by ribs, as is frequently the case in cast iron, about one-half of the material of the ribs may be regarded as adding to the thickness of the plate.

Prob. 160a. Which is the stronger, a circular plate carrying a load P uniformly distributed, or one carrying a load $\frac{1}{2}P$ distributed over an area at the middle which is one-fourth of the area of the plate?

Prob. 160b. Show that the formula for the discussion of a circular steel plate, fixed around its circumference and loaded at the middle, is $T = 1.48 P/d^2$ when $r/r_0 = 20$, and $T = 1.78 P/d^2$ when $r/r_0 = 40$.

ART. 161. ELLIPTICAL PLATES

Elliptical plates are commonly used for the covers of man-holes in boilers and stand-pipes. Let R be the uniform unit-pressure on the plate, a the semi-major axis, and b the semi-minor axis of the ellipse. It is required to find the maximum unit-stress T on the tensile side of the plate.

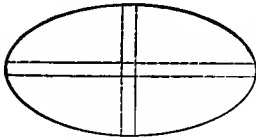

Fig. 161

Taking the case where the plate is simply supported around the circumference, let two elementary strips be drawn as in Fig. 161, one along the major axis and the other along the minor axis. Let W_1 and W_2 be the loads on these strips, and f_1 and f_2 their deflections. At the center of the ellipse the deflections of the strips are, from Art. 55,

$$f_1 = W_1 a^3 / \beta EI \quad f_2 = W_2 b^3 / \beta EI$$

and because these are equal, $W_1 a^3$ must be equal to $W_2 b^3$. Since the reactions at the ends are proportional to the loads, it follows that the reactions at the ends of the axes are inversely as the cubes of the lengths of the axes. Hence the total weight πabR is not uniformly distributed on the support around the circumference, but the greatest reaction per linear unit will be found at the ends of the minor axis and the least at the ends of the major axis. It should hence be expected that the horizontal flexural stresses at the center are the greatest in directions parallel to the minor axis, and that in case of rupture a crack would begin at the center and run along the major axis; this is verified by tests.

The theoretic solution of this very difficult problem cannot well be given here. From the discussion of Grashof and the experiments of Bach the following approximate formula may be written for wrought-iron and steel elliptical plates supported around the circumference:

$$T = 2Ra^2b^2 / (a^2 + b^2)d^2 \quad (161)$$

in which a and b are the semi-axes, d the thickness of the plate, R the unit-pressure upon it, and T the allowable tensile unit-

stress. When a and b are equal, the ellipse becomes a circle of radius r , and $T = R(r/d)^2$ as found in Art. 159.

For a cast-iron plate supported along its circumference, the numerical coefficient in the above formula will be $\frac{9}{4}$ instead of 2. For plates fixed around the circumference, the coefficient will be about $\frac{4}{3}$ for wrought iron and steel, and about $1\frac{1}{2}$ for cast iron. These numbers are derived by taking the factor of lateral contraction as $\frac{1}{3}$ for wrought iron and steel, and as $\frac{1}{4}$ for cast iron. In Germany the value $\lambda = \frac{3}{10}$ is generally used for both cast iron and steel, and this will slightly modify the above numerical coefficients.

A common proportion for manhole covers is to make $a/b = 1.5$, that is, the length is 50 percent greater than the width. Let the length be 24 inches and the width 16 inches, and let it be required to find the proper thickness when the cast-iron manhole cover is used in a stand-pipe under a head of water of 50 feet. Here $a = 12$ and $b = 8$ inches, $R = 22$ pounds per square inch, while the allowable T for cast iron may be taken as 3 000 pounds per square inch. Then, since the plate is supported around the circumference, the numerical coefficient in the formula will be $\frac{9}{4}$, and from it is found $d = ab(\frac{9}{4}R/(a^2 + b^2)T)^{\frac{1}{2}} = 0.86$ inches, so that a thickness of $\frac{7}{8}$ inches will be sufficient safely to withstand the pressure.

Prob. 161*a*. Show that the allowable unit-pressure R for a cast-iron elliptical manhole cover having the proportions $a/b = 1.5$, is given by $R = 2.92(d/b_1)^2T$, in which b_1 is the width of the plate.

Prob. 161*b*. Compute the safe unit-pressure for a cast-iron manhole cover of 20 inches length, 13 inches width, and $1\frac{1}{4}$ inches thickness. What head of water will produce this pressure?

ART. 162. RECTANGULAR PLATES

A rectangular plate of length $2l$ and width $2m$, subject to a uniform pressure R per square unit, distributes that pressure over the support in a similar manner to the elliptical plate. The reaction per linear unit is less on the ends than on the sides,

and is greater at the middle of the ends and sides than near the corners. Rupture tends to occur near the center and parallel to the longer side. The approximate formula derived from the discussion of Bach for iron and steel plates is,

$$T = \alpha R l^2 m^2 / (l^2 + m^2) d^2 \quad (162)$$

in which T is the maximum tensile unit-stress at the middle of the lower side of the plate, and d is the thickness of the plate. The values of the number α , as determined by the experiments of Bach, ranged from $\frac{3}{4}$ to $\frac{5}{8}$, according as the condition of the edges approached that of a mere support or a state of fixedness.

For a square plate l and m are equal, and the above expression may then be reduced to the forms,

$$T = \frac{3}{8} R (l/d)^2 \quad \text{and} \quad T = \frac{5}{8} R (l/d)^2$$

the first being for free and the second for fixed edges. The numerical constants in these formulas are derived from the discussion of experiments and hence stand upon a different basis from those deduced for circular plates; probably the formulas will apply better to cases of rupture than to cases where T is within the elastic limit of the material.

This problem has been discussed theoretically by Grashof with the conclusion that the formula for a square plate fixed at the middle of each edge is $T = (\tau - \lambda^2) R (l/d)^2$, where λ is the factor of lateral contraction. A plate might be fixed in this manner by a bolt at the middle of each edge, but such an arrangement is unusual, the common method being to bolt it to the support at many points. When $\lambda = \frac{1}{3}$, this formula reduces to $T = \frac{5}{8} R (l/d)^2$, which is intermediate between those given for free and for fixed edges in the last paragraph.

While the numerical coefficients for square plates, as deduced by different authors, vary somewhat, it is well established that the unit-stress T at the middle of the plate varies directly as its area and the unit-pressure R , and inversely as the square of its thickness. The strength of a square plate, as measured by the pressure R that it can carry, varies directly as the square of the

thickness and inversely as the area; this law is the same as that previously found for circular plates.

Prob. 162. Prove that the maximum unit-stress for a square plate, caused by a given uniform load W , is independent of the size of the plate.

ART. 163. HOLLOW SPHERES

Hollow spheres are used in certain forms of boilers under inside steam-pressure. The ends of steam and water cylinders are sometimes made hemispherical instead of plane, in order to avoid flexure; the base of a steel water tank is often made a hemisphere for the same reason. If the thickness of the sphere is small compared to its radius, the investigation is simple. Let r be the radius and t the thickness. Let R be the inside pressure per square unit, and S the tensile unit-stress on the annulus. Then on any great circle the total pressure is $\pi r^2 R$, and this is resisted by the tension $2\pi r t S$ in the section of the annulus. By equating these, there is found,

$$2tS = rR \quad \text{or} \quad S = \frac{1}{2}R \cdot r/t$$

which is the formula generally used for thin spheres under inner pressure. But in strictness S is the apparent stress, while another equal in intensity acts at right angles to it. Thus from Art. 139 the true stress on the outside surface is $T = S - \lambda S$, while that on the inside surface is $T = S - \lambda S + \lambda R$. Using $\frac{1}{3}$ for the value of λ , and inserting the above value of S , there result,

$$T_1 = \frac{1}{3}R \cdot r/t \quad \text{and} \quad T_2 = \frac{1}{3}R + \frac{1}{3}R \cdot r/t$$

for the true tensile unit-stresses on the outside and inside surfaces respectively. Both of these are less than S , and hence the usual formula for thin spheres (Art. 31) errs on the side of safety.

The investigation of a thick hollow sphere under inside and outside pressure will be similar to that of the thick cylinder in Art. 149. Let r_1 be the inside and r_2 the outside radius, R_1 and R_2 being the corresponding pressures per square unit of surface. Fig. 149*b* may represent a partial section of the sphere, x being the radius of any elementary annulus where the radial unit-stress

is R and the tangential unit-stress is S . From the symmetry of the sphere it is seen that another stress S acts at right angles to the one shown in the figure. Thus an elementary particle at any position in the annulus is held in equilibrium by three principal stresses R , S , and S . The sum of these is regarded as constant throughout the annulus (Art. 183), and accordingly $2S + R = 3C_1$ is one equation between S and R , where C_1 is a constant which is to be determined.

Now the inside pressure on a great circle whose radius is x is $\pi x^2 R$, and the outside pressure on a great circle whose radius is $x + \delta x$ is $\pi(x + \delta x)^2(R + \delta R)$, both of these being perpendicular to the plane of the circle. The difference of these is equal to the resisting stress in the elementary annulus, which is $2\pi x \delta x \cdot S$. Stating this equation and omitting quantities of the second order, a second relation between S and R is found. Accordingly,

$$2S + R = 3C_1 \quad x\delta R + 2R\delta x = 2S\delta x$$

are the two conditions for determining S and R . Substituting in the second equation the value of S from the first and integrating, the value of R in terms of x is found, and then that of S is known; thus,

$$S = C_1 + C_2/x^3 \quad \text{and} \quad R = C_1 - 2C_2/x^3 \quad (163)$$

in which C_2 is a constant of the integration. These formulas for hollow spheres is seen to be analogous to those for thick cylinders, the radii being cubed instead of squared. The formula for S is the most important one and S has its greatest value at the inside surface of the hollow sphere.

Values of the constants C_1 and C_2 may be found from the formula for R . Regarding the unit-pressures R_1 and R_2 as without sign, R becomes $-R_1$ when $x = r_1$ and R becomes $-R_2$ when $x = r_2$; then,

$$C_1 = (r_1^3 R_1 - r_2^3 R_2) / (r_2^3 - r_1^3) \quad C_2 = \frac{1}{2} r_1^3 r_2^3 (R_1 - R_2) / (r_2^3 - r_1^3)$$

and these when placed in (163) give the formulas deduced by Lamé for thick hollow spheres. The most common case is that where there is no outside pressure R_2 ; here the tensile unit-

stresses on the inside and outside surfaces are,

$$S_1 = R_1 \left(\frac{1}{2} r_2^3 + r_1^3 \right) / (r_2^3 - r_1^3) \quad S_2 = R_1 \cdot \frac{3}{2} r_1^3 / (r_2^3 - r_1^3) \quad (163)'$$

and the first of these gives the greater unit-stress. For example, if $r_2 = 2r_1$, then $S_1 = \frac{5}{7} R_1$, and when r_2 is nearly as large as r_1 , then S_1 is nearly $\frac{1}{2} R \cdot r/t$, as previously found for a thin hollow sphere in Art. 31.

The above gives the apparent unit-stresses. To find the true unit-stress T_1 at the inside surface of a steel hollow sphere, the factor of lateral contraction is to be taken as $\frac{1}{3}$, and then by Art. 139,

$$T_1 = S_1 - \frac{1}{3} S_1 + \frac{1}{3} R_1 = \frac{1}{3} R_1 (2r_2^3 + r_1^3) / (r_2^3 - r_1^3) \quad (163)''$$

which will generally be found to be less than S_1 . It is therefore on the safe side to use the formula for S_1 in cases of design.

As an example, let a steel cylinder 4 inches in inside and 8 inches in outside radius have a hemispherical end with the same radii, and be subject to an inside water pressure of 4 000 pounds per square inch. Then the apparent tensile stress on the inside surface of the hemisphere is found from (163)' to be 2 860 pounds per square inch, while (163)'' gives the true tensile stress as 3 240 pounds per square inch; hence the true stress is about 13 percent larger than the apparent. For the cylinder itself, the apparent and true tensile stresses at the inside surface may be computed from (150) and (152)'' and these values are $S_1 = 6 700$ and $T_1 = 7 600$ pounds per square inch, so that the true stress is 13 percent greater than the apparent for the cylinder.

If the end of this cylinder is a flat plate of the same thickness as the cylinder, or 4 inches, and fixed around the circumference, the true stress on the outer side is found from (159)' to be $T = \frac{6}{18} \times 4 000 = 16 000$ pounds per square inch; this is five times as great as that for the hemisphere, and more than double the greatest stress in the cylinder. The advantage of hemispherical ends in reducing the stresses is thus seen to be very great. It may be remarked, in conclusion, that the theory of internal stress in cylinders and spheres is not perfect, for it fails to give the same

results for the common surface of junction of a cylinder and hemisphere. This indicates that the assumption made regarding the constancy of $2S + R$ does not probably hold good for a hemisphere attached to a cylinder.

Prob. 163*a*. A hollow sphere is to be subject to a steam-pressure of 600 pounds per square inch, its inner radius being 8 inches. Compute its thickness, so that the greatest tensile stress may be 1 000 pounds per square inch.

Prob. 163*b*. Investigate the discrepancy between the formulas for hollow cylinders and hollow spheres for the following numerical case. A hollow cylinder with hollow hemispherical ends, the inside diameters being 8 inches and the outside diameters 12 inches, is subject to an inside water pressure of 2 400 pounds per square inch. Compute, by Art. 152, and by this article, the true maximum unit-stress T for the common plane of junction of cylinder and hemisphere.

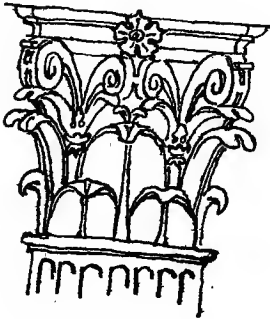

CHAPTER XVIII

MISCELLANEOUS DISCUSSIONS

ART. 164. CENTRIFUGAL TENSION

WHEN the center of gravity of a body of weight P revolves around an axis with the uniform velocity v_1 and r is the distance of the center of gravity from the axis, there is generated a stress in the cord or bar that connects the body with the axis. This centrifugal force Q is shown in works on theoretical mechanics to be $Q = Pv^2/gr$, where g is the acceleration of a body falling vertically under the action of gravity near the surface of the earth. The case shown in Fig. 164a is that of a bar of uniform section area and length l , the weight P being attached to one end while it revolves around an axis A at the other end. It is required to find the centrifugal stress in the bar at A when the speed of n revolutions per second is maintained.

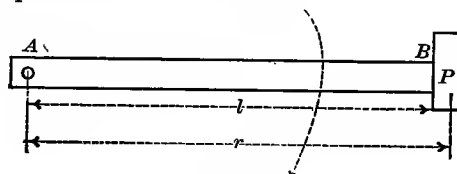

Fig. 164a

Let r be any distance from the axis; the velocity at this distance is $2\pi rn$, or if ω is the angular velocity, the velocity v at the distance r is $r\omega$, and the relation between n and ω is given by $\omega = 2\pi n$. Now let W be the weight of the bar, $\frac{1}{2}l$ the distance of its center of gravity from the axis, and v_1 the velocity of that center of gravity; then,

$$Q = P \frac{v^2}{gr} + W \frac{v_1^2}{\frac{1}{2}gl} = (Pr + \frac{1}{2}Wl)\omega^2/g$$

gives the centrifugal force at the axis; this produces a tension in the bar and a sidewise compression and flexure on the axis.

As an example, let a bar of wrought iron 2×2 inches and 6 feet long have a weight of 400 pounds with its center of gravity

6½ feet from the axis of revolution. It is required to find the number of revolutions per second in order to produce rupture. Solving the last equation for ω , and placing $Q=50\,000$ pounds per square inch, $P=400$ pounds, $W=80$ pounds, $g=32.16$ feet per second per second, $l=6$ feet, and $r=6\frac{1}{4}$ feet, there is found $\omega=48.4$ radians per second, and hence the speed required to cause rupture is $n=48.4/2\pi=7.8$ revolutions per second.

When $P=0$ in the above formula, the case is that of a bar of uniform section area and of weight W , and the tensile stress at the axis is $Q=\frac{1}{2}Wl\omega^2/g$. The tensile stress in such a bar is 0 at the free end and it increases toward the axis, where it has the value Q . Let a be the area of the cross-section, w the weight of a unit of volume, and x any distance from the axis. Then the weight of the length $l-x$ is $wa(l-x)$ and the distance of its center of gravity from the axis is $\frac{1}{2}(l+x)$, so that the centrifugal force of this part of the bar is,

$$Q'=wa(l-x) \cdot \frac{1}{2}(l+x)\omega^2/g=wa\omega^2(l^2-x^2)/2g$$

and this is the tensile stress at the distance x from the axis. When $x=l$, then $Q'=0$; when $x=0$, then $Q'=wal^2\omega^2/2g$, which is equal to the above value of Q . The tensile unit-stress in the bar at any distance x from the axis is $R=Q'/a$. This may be written $R=\frac{1}{2}(w\omega^2/g)(l^2-x^2)$ and it will be seen to be closely analogous with the expression for radial unit-stress in a revolving fly-wheel or millstone.

Another case is that of the thin circular hoop of mean radius r and thickness t , shown in the first diagram of Fig. 164*b*. Let

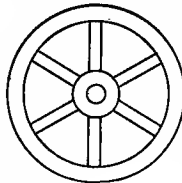
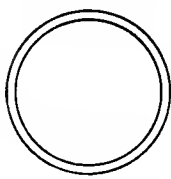

Fig. 164*b*

W be its weight, which is equal to $2\pi rwb$, if w is the weight of the material per cubic unit, and b is the width of the hoop perpendicular to the plane of the drawing. The centrifugal force acting on the axis is here zero

because the center of gravity of the hoop coincides with the axis. There is hence no pressure on the axis, but the centrifugal force acts radially upon the hoop and produces tension in it in the

same manner as inside water pressure in a thin pipe. The centrifugal force due to an angular velocity ω is $2\pi wbr^2t\omega^2/g$ for the entire weight, and hence the radial unit-pressure R is found by dividing this by the area $2\pi br$, or $R = wt\omega^2/g$. Now, referring to Art. 30, it is seen that $rR = tS$ is the relation between the inside unit-pressure R and the tangential tensile unit-stress S in the hoop. Therefore the value of S is,

$$S = (w\omega^2/g)r^2 \qquad \omega = 2\pi n$$

in which n is the number of revolutions per second. For example, let it be required to find the tensile stress in a cast-iron hoop, 4 inches wide, 2 inches thick, and 62 inches in outside diameter when making 300 revolutions per minute. Here $w = 450/1728$ pounds per cubic inch, $r = 30$ inches, $n = 5$ revolutions per second, and $g = 32.16 \times 12$ inches per second per second; then S is found to be 600 pounds per square inch, which is a low value for cast iron in tension.

The above formula is frequently applied to the rim of a fly-wheel, taking r as the mean radius, but it will now be shown that it gives the correct tangential unit-stress when r is the radius of the outside circumference. Let r_1 and r_2 be the radii of the inside and outside circumferences of the rim, and let x be any intermediate radius. The above reasoning shows that the outward radial unit-stress due to the matter in an annulus of thickness δx is $(w\omega^2/g)x\delta x$ and this may be called δR , it being the increment of the radial tensile unit-stress R . Referring to the reasoning in Art. 149, it is seen that the two equations,

$$S + R = 2C \qquad x \cdot \delta R + R \cdot \delta x = S \cdot \delta x$$

are applicable to this case. Inserting the above expression for δR and solving for S and R , there are found,

$$S = C + \frac{1}{2}(w\omega^2/g)x^2 \qquad R = C - \frac{1}{2}(w\omega^2/g)x^2$$

Now when $x = r_2$, then $R = 0$, since there is no radial stress on the outside circumference; hence $C = \frac{1}{2}(w\omega^2/g)r_2^2$, and hence,

$$S = \frac{1}{2}(w\omega^2/g)(r_2^2 + x^2) \qquad R = \frac{1}{2}(w\omega^2/g)(r_2^2 - x^2)$$

are the tangential and radial unit-stresses at any distance x from the axis, both of these being tension. Hence S is the greatest

at the farthest distance from the axis, and,

$$S_1 = \frac{1}{2}(w\omega^2/g)(r_2^2 + r_1^2) \quad S_2 = (w\omega^2/g)r_2^2$$

are the tangential unit-stresses at the inside and outside circumferences of the rim. It is seen that S_2 is independent of r_1 and and that it is the greatest tangential unit-stress.

For a solid grindstone or millstone, r_1 is 0 and the greatest unit-stress S_2 is the same as for a thin hoop of outside radius r_2 , while S_1 at the center is $\frac{1}{2}S_2$. These, like all of the foregoing values, are apparent stresses. The true stresses corresponding to the actual deformations (Art. 139) differ from the apparent ones at all points except tangentially on the outside circumference. Let λ be the factor of lateral contraction; then for any distance x from the axis, $T = S - \lambda R$ for the tangential unit-stress and $T' = R - \lambda S$ for the radial unit-stress. For the outside circumference of the rim, where $x = r_2$,

$$T_2 = (w\omega^2/g)r_2^2 \quad T_2' = -(w\omega^2/g)\lambda r_2^2$$

and for the inside circumference of the rim, where $x = r_1$,

$$T_1 = \frac{1}{2}(w\omega^2/g)(r_2^2 - \lambda r_2^2 + r_1^2 + \lambda r_1^2)$$

$$T_1' = \frac{1}{2}(w\omega^2/g)(r_2^2 - \lambda r_2^2 - r_1^2 - \lambda r_1^2)$$

The values of T_2 and T_2' are independent of r_1 , that of T_1 decreases as r_1 decreases, while that of T_1' increases as r_1 decreases. The greatest tangential stress is at the outside circumference, and here it is that rupture begins by one or more radial cracks.

Prob. 164a. A cast-iron bar is 3×2 inches in section, and 9 feet long. Through the middle and normal to the flat side is a hole $\frac{3}{4}$ inches in diameter. If the bar is revolved around an axis through this hole, how many revolutions per second will produce rupture?

Prob. 164b. A solid steel circular saw is 4 feet in diameter and makes 2700 revolutions per minute. Compute the true tangential unit-stresses at the circumference and at the center. How many revolutions per minute will cause a tangential stress of 35 000 pounds per square inch?

Prob. 164c. For influence of the spokes of a fly-wheel see Transactions American Society Mechanical Engineers, Vol. 20, p. 209.

ART. 165. CENTRIFUGAL FLEXURE

The rod that connects the cross-head of a steam engine with the crank pin is subject to a centrifugal flexural stress owing to the fact that one end revolves in a circle. The horizontal rod, or parallel bar, joining two driving wheels of a locomotive is another instance of centrifugal flexure; this is simpler than the connecting rod, because all points are revolving with the same velocity, and hence it will be discussed first.

Let u be the velocity of a locomotive and v the velocity of revolution of the end of the parallel rod around the axle of the driving wheel to which it is attached. Let r_1 be the radius of the wheel, and r the radius of the circle of revolution of the end of the parallel rod. Then since the velocity of revolution of the circumference of the wheel is the same as the linear velocity of the locomotive, it follows that $v = u \cdot r/r_1$. Now not only the end of the parallel rod, but every point in it, is revolving with the

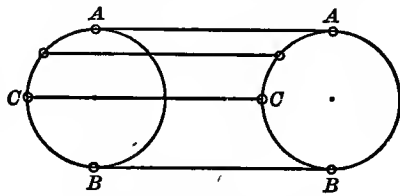

Fig. 165a

velocity v in a circle of radius r . Thus a centrifugal force is generated which produces flexural stresses. When the rod is at its lowest position BB , this centrifugal force acts as a downward uniform load producing flexure; at the highest position AA it acts as an upward uniform load producing flexure; at the position CC , on the same level as the axles, it produces a compressive stress in the direction of the length of the rod.

Let w be the weight of the parallel rod per linear unit; then, from rational mechanics, the centrifugal force is,

$$w' = wv^2/gr \quad \text{or} \quad w' = wu^2r/gr_1^2$$

which may be called the centrifugal load per unit of length. The rod being a beam supported at its ends, having a length l , a breadth b , and a depth d , the maximum unit-stress due to this uniform load is, from the flexure formula (41),

$$S = Mc/I = 3w'l^2/4bd^2$$

which is the flexural stress due to centrifugal force when the bar is at its highest or at its lowest position. If the bar is not rectangular, as is generally the case, the values of c and I for its cross-section are to be obtained by the methods which are explained in Arts. 42 and 43.

In this formula g is the acceleration of gravity, or 32.16 feet per second per second. In using it in formulas, however, all quantities should be expressed in terms of the same linear unit, the inch being preferable. For example, let a locomotive be running at 60 miles per hour, the radius of the drivers being 3 feet and that of the parallel rod 1 foot, this being of steel, 4 inches deep, 2 inches thick, and 8 feet long. Here $u = 88$ feet per second $= 12 \times 88$ inches per second, $g = 32.16 \times 12$ inches per second per second, $r_1 = 3 \times 12$ inches, $r = 1 \times 12$ inches, $l = 8 \times 12$ inches, $b = 2$ inches, $d = 4$ inches, and $w = 2.27$ pounds per linear inch. The centrifugal load per inch then is $w' = 61$ pounds, and the maximum flexural stress is $S = 13\ 200$ pounds per square inch, which is probably not sufficiently low when it is considered that the parallel rod is subject to rapid alternating stresses and perhaps to shocks.

The connecting rod moves in a circle of radius r at the crank pin, while the other end moves only in a straight line. Thus at the end A there is no centrifugal load, while at B the centrifugal load is the same as given by the above expression for

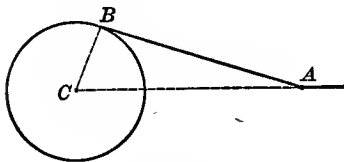

Fig. 165b

w' . When the rod is in the position shown in Fig. 165b, it is a beam acted upon by a centrifugal load which varies uniformly from 0 at A to w' at B . The total load is hence $\frac{1}{2}w'l$, the reaction at A is $\frac{1}{8}w'l$, and that at

B is $\frac{3}{8}w'l$. The bending moment for any section distant x from the end A then is,

$$M = \frac{1}{8}w'l \cdot x - \frac{1}{2}w' \left(\frac{x^2}{l} \right) \cdot \frac{1}{3}x = \frac{1}{6}w' (l^2x - x^3) / l$$

and the maximum value of M occurs at the section for which $x^2/l^2 = \frac{1}{3}$, which gives maximum $M = 0.0638w'l^2$. Then from

the flexure formula (41), the flexural unit-stress is,

$$S = Mc/I \qquad S = 0.383w'l^2/bd^2$$

the second being for a rectangular section in which w' has the same value as for the parallel rod.

By comparing the formulas for rectangular parallel and connecting parallel rods it is seen that the unit-stress S for the former is about twice as great, if the length and section area are the same in the two cases. The parallel rod needs the greatest cross-section at the middle, while the connecting-rod needs the greatest cross-section at about 0.6*l* from the cross-head.

Prob. 165. The connecting rod of an engine is 2 feet long and it is attached to a crank pin at a distance of 6 inches from the axis of a fly-wheel. If the wheel makes 750 revolutions per minute, find a square cross-section for the connecting rod so that the centrifugal unit-stress S may be 4200 pounds per square inch.

ART. 166. UNSYMMETRIC LOADS ON BEAMS

It was explained in Art. 43 that two axes may be drawn in the plane of any section area of a beam, these passing through the center of gravity of the section and being at right angles to each other, so that the moment of inertia of the section is greater for one axis and less for the second axis than for any other axis through the center of gravity. These are called 'principal axes', and the moments of inertia with respect to them are those required in all common cases; Table 6 gives these moments of inertia for I sections and Table 8 those for T sections. The great majority of beam sections are symmetric with respect to both of the principal axes, while a few like the T and bulb sections are symmetric with respect to one principal axis only. The L section of Fig. 42*c* and the Z section of Fig. 42*d* are unsymmetric with respect to both principal axes; these are not commonly used as beams, but when so used, the flexure formula (41) cannot be applied to their correct discussion without the determination of the moments of inertia for the principal axes.

A load on a beam is said to be 'unsymmetric' when its vertical

plane does not coincide with one of the principal axes of the section area. The simplest case is that shown in Fig. 166*a*, where the broken lines show the principal axes of a rectangular section, and the load P is applied at a certain distance from the vertical axis. If the load is on a beam with supported ends, it is plain that the reactions of the end will not be uniformly distributed over the supports and hence the right-hand part of the section will be but slightly stressed. If the beam is fastened to the supports, the reaction may be downward or negative on the right-hand part and upward on the left-hand part, so that torsional stresses will be developed. This case is one that should be avoided, for it is clear that parts of the beam are much more highly stressed than when the load is placed so that its resultant coincides with the vertical principal axis.

Fig. 166*a*Fig. 166*b*Fig. 166*c*Fig. 166*d*

Fig. 166*b* shows a case of unsymmetric loading which occurs in a purlin beam connecting two roof trusses. The upper chords or main rafters of the truss being inclined to the horizontal at the angle ϕ , the upper and lower surfaces of the horizontal purlin have the same inclination, and the load on its upper surface makes the angle ϕ with the principal axis 2-2. Let I_1 and I_2 be the moments of inertia of the section area with respect to the principal axes 1-1 and 2-2. Let M be the bending moment at the dangerous section due to the vertical loads, then the component $M \cos \phi$ acts in the plane 2-2 and produces the unit-stress $S_1 = c_1 M \cos \phi / I_1$, where c_1 is the distance from 1-1 to the upper or lower surface of the beam. When ϕ is not a large angle, the unit-stress S_1 is frequently computed by this method and regarded as the actual flexural stress. For example, let the angle ϕ be 30 degrees, the simple beam be 4 inches wide, 6 inches deep, 13 feet in span, and be subject to a total uniform load of 600 pounds. Here $M = 11\,700$ pound-inches, $I_1 = 72$ inches⁴, $c_1 = 3$

inches, and then $S_1 = 490$ pounds per square inch; this is much smaller than the actual unit-stress.

Another method of dealing with the last case is to consider the neutral axis mn as horizontal, to find the values of c and I with respect to it, and then to compute the unit-stress from the flexure formula $S = Mc/I$. Here c is the distance from the remotest fiber at the upper or lower corner to the neutral axis and it is easy to show that $c = c_1 \cos\phi + c_2 \sin\phi$, where c_1 and c_2 are the coordinates of the corner with respect to the principal axes 1-1 and 2-2. It may also be shown that $I = I_1 \cos^2\phi + I_2 \sin^2\phi$ gives the moment of inertia of the section area with respect to the axis mn . For the above numerical example, $c_1 = 3$ and $c_2 = 2$ inches, $I_1 = 72$ and $I_2 = 32$ inches⁴; then $c = 3.60$ inches, $I = 62$ inches⁴, and finally $S = 680$ pounds per square inch. It is, however, not correct to assume that the neutral axis is horizontal and the computed value of S is too small.

A more precise method is to resolve the vertical load on the purlin into components parallel to the principal axes, those normal to 1-1 producing the moment $M \cos\phi$ and those normal to 2-2 producing the moment $M \sin\phi$. Then the flexural unit-stress due to the first moment is $S_1 = c_1 M \cos\phi / I_1$, and that due to the second moment is $S_2 = c_2 M \sin\phi / I_2$. The actual unit-stress on the remotest fiber then is,

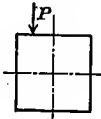
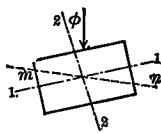
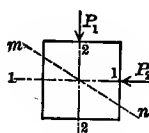
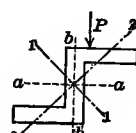
$$S = S_1 + S_2 = M \left(\frac{c_1 \cos\phi}{I_1} + \frac{c_2 \sin\phi}{I_2} \right) \quad (166)$$

For the above numerical example, this formula gives $S = 780$ pounds per square inch, which is a more reliable value than those found by the other methods. It does not, however, give sufficient weight to the influence of the component $M \sin\phi$, since the forces that cause this moment act in the plane of the upper surface of the beam. For a case like Fig. 166c, where the forces P_1 and P_2 act in the lines of the principal axes, this method is strictly correct, M being the moment due to the resultant P which makes the angle ϕ with 2-2; by discussing this case it can be shown that the neutral axis mn is not normal to the plane of M except when I_1 and I_2 are equal.

Formula (166) applies to the discussion of the Z bar shown in Fig. 166*d*, as soon as the values of c_1 , c_2 , I_1 , I_2 , and ϕ are known. Table 11 gives data for a few Z bars with equal legs, this being a part of the table in the Cambria pocket book. The moments of inertia I_a and I_b are those with respect to the axes $a-a$ and $b-b$, while the principal axes are 1-1 and 2-2. The value of I_2 is found by $I_2 = ar_2^2$, where a is the section area and r_2 the least radius of gyration. The value of I_1 is found by subtracting I_2 from the sum $I_a + I_b$. The tangent of the angle ϕ is given in the sixth column of the table, and from this the values of $\cos\phi$ and $\sin\phi$ are readily found. For example, take a Z bar 8 inches deep with legs 3 inches long, and let a load P be applied as shown in Fig. 166*d* which produces a bending moment M equal to 120 000 pound-inches. Making a drawing of the section from the data in the table, the measured values of c_1 and c_2 normal to the axes 1-1 and 2-2 are found to be 4.61 and 1.60 inches. From the given value $\tan\phi = 0.27$, there are found $\cos\phi = 0.965$ and $\sin\phi = 0.260$. Following the above rules, the principal moments of inertia are $I_2 = 2.56$ and $I_1 = 50.24$ inches⁴. The formula (166) then gives $S = 30\ 100$ pounds per square inch for the stress on the upper or lower corner of the end of the leg. By using the rough method in which aa is taken as the neutral axis, there is found $S = 120\ 000 \times 4/44.64 = 10\ 800$ pounds per square inch, which is about one-third of the former value. Consideration of Fig. 166*a* indicates, however, that the actual unit-stress in the corner of the Z bar is probably higher than 30 100 pounds per square inch.

Prob. 166*a*. Show that the angle ϕ which gives the greatest flexural unit-stress for the cases of Fig. 166*b* is that for which $\tan\phi = c_2 I_1 / c_1 I_2$.

Prob. 166*b*. Show that the angle θ between the neutral axis mn and the principal axis 1-1 in Fig. 166*b* is given by $\tan\theta = -(I_1/I_2)\tan\phi$. For the above example of the purlin beam, show that θ is $51\frac{3}{4}$ degrees, and that hence the neutral axis is inclined $21\frac{3}{4}$ to the horizontal.

Prob. 166*c*. Compute the unit-stress S for a Z bar 6 inches deep with legs $3\frac{1}{2}$ inches long, when used as beam under a bending moment of 90 000 pound-inches.

ART. 167. EULER'S MODIFIED FORMULA

Euler's formula for columns expresses the condition of indifferent equilibrium, or that state which borders between stable and unstable equilibrium. In all cases of indifferent equilibrium slight causes produce marked effects, and hence it seems important to inquire whether Euler's formula, as given in Art. 78, represents the exact relation between P/a and l/r . It will be apparent on reflection that, while the formula contains but one length l , there are really three different lengths that should be taken into consideration. Let l represent the length of the straight column in its unstrained state, l_1 the length of the straight column after compression by the unit-stress P/a , and l_2 the chord of the deflected curve after lateral bending.

Referring now to formula (45), it is seen that this does not include the effect of the longitudinal compression P/a . To introduce this, let S be the total unit-stress produced by both flexure and compression; then in the demonstration the first four formulas will be thus modified:

$$e = (S - P/a) \frac{dl}{E}, \quad \frac{R}{dl_1} = \frac{c}{e}, \quad \frac{S - P/a}{c} = \frac{E \delta l_1}{R \delta l} = \frac{M}{I}$$

and then the reasoning leads to the following modified equation of the elastic curve of the deflected column,

$$EI \frac{\delta^2 y}{\delta x^2} = M \frac{\delta l}{\delta l_1} = M \frac{l}{l_1}$$

Passing now to Euler's deduction in Art. 78, the bending moment M is replaced by $-Py$, and the equation of the elastic curve for a round-ended column is found to be,

$$y = f \sin x (Pl/EI l_1) \dagger$$

Here $y=0$ when $x=l_2$; hence by the same reasoning as before there is deduced the formula,

$$P = \pi^2 EI \cdot l_1 / l_2^2 \quad \text{or} \quad P/a = \pi^2 E r^2 l_1 / l_2^2$$

which is the condition for the state of indifferent equilibrium.

To complete the investigation, l_1 and l_2 are to be expressed in terms of l . Now $l - l_1$ is the deformation due to the longi-

tudinal compression P/a , and from the definition of the modulus of elasticity in Art. 9 its value is $l_1 = l(1 - P/aE)$. To find l_2 it is plain that $l_1 - l_2$ is the fall at the end of the column due to the lateral flexure and that $P(l_1 - l_2)$ is the work done in this fall. This external work must equal the internal work of the flexural stresses. From Art. 123,

$$dK = \frac{M^2 dx}{2EI} = \frac{P^2 y^2 dx}{2EI} = \frac{P^2 f^2}{2EI} \sin^2 \frac{\pi x}{l_2} \cdot dx$$

and integrating this between the limits $x=0$ and $x=l_2$, the internal work K is found to be $P^2 f^2 l_2 / 4EI$. Therefore, equating the external to the internal work, the value of $l_1 - l_2$ is found to be $Pf^2 l_2 / 4EI$. Accordingly,

$$l_1 = l(1 - P/aE) \quad l_2 = l(1 - P/aE) / (1 + Pf^2 / 4ar^2)$$

are the required values in terms of the original length.

The quantities P/aE and $Pf^2 / 4ar^2$ are small in comparison with unity, and hence their squares and their product may be neglected; also the reciprocal of $1 - P/aE$ may be taken as $1 + P/aE$. Introducing the values of l_1 and l_2 into the above expression for P it reduces to,

$$\frac{P}{a} = \pi^2 E \frac{r^2}{l^2} \left(1 + \frac{P}{aE} + \frac{P}{aE} \frac{f^2}{2r^2} \right),$$

and since $\pi^2 E r^2 / l^2$ is a close approximation to the value of P/a it may replace the latter in the parenthesis, giving finally,

$$\frac{P}{a} = \pi^2 E \frac{r^2}{l^2} \left(1 + \pi^2 \frac{r^2}{l^2} + \pi^2 \frac{f^2}{2l^2} \right) \quad (167)$$

which is Euler's modified formula for round-ended columns. By writing $2\frac{1}{4}\pi^2$ instead of π^2 it applies to a column with one end round and the other fixed, and by writing $4\pi^2$ instead of π^2 it applies to a column with both ends fixed.

Another modification of Euler's formula which has been frequently given is derived by considering only l and l_1 , so that the equation of the elastic curve becomes,

$$EI \frac{\partial^2 y}{\partial x^2} = M \frac{l}{l_1} \quad \text{or} \quad (E - P/a) \frac{\partial^2 y}{\partial x^2} = M$$

Accordingly Euler's formulas as deduced in Art. 78 are to be modified by replacing E by P/a , and then solving for P/a . For a column with both ends round this leads to the form,

$$\frac{P}{a} = \frac{\pi^2 E (r/l)^2}{1 + \pi^2 (r/l)^2}$$

which shows that the unit-load required to hold the column in indifferent equilibrium is less than $\pi^2 E (r/l)^2$. By taking l_2 into account, as is done above, the unit-load is found to be greater than $\pi^2 E (r/l)^2$, and (167) also indicates that P slightly increases with the deflection f , so that after a slight deflection has been attained the value of f is not wholly indeterminate, as the common theory teaches.

Prob. 167. Show that the fall of the load P , due to direct compression of the column, equals the fall due to the lateral flexure when f is equal to $2r$.

ART. 168. TESTING MACHINES

The first experiments on the strength of materials were made on the rupture of beams of timber. A picture in Galileo's *Discorsi* (Leiden, 1638), shows a cantilever beam projecting from a wall and loaded at the free end with a heavy weight, and it was probably from experiments of this kind that Galileo was led to the conclusion that the strength of rectangular beams varies as the squares of their depths. During the eighteenth century experiments were made by Mariotte, Parent, and others on timber in flexure and tension, only questions of ultimate strength being investigated, while the elastic limit was unrecognized. Hooke's law of the proportionality between stress and deformation had, indeed, been announced in 1678, but it was not until 1798 that Girard made the first comprehensive series of experiments on the elastic properties of beams. Early in the nineteenth century appeared the 'Lectures on Natural Philosophy' by Young in which is found a clear presentation of many of the laws of flexure both under static forces and under shock. It also introduces for the first time the modulus of elasticity, E , but fails to note that it can only be deduced or applied when the elastic limit of

the material is not surpassed. A little later Barlow, Tregdold, and Hodgkinson experimented on timber and cast iron, both in the form of beams and of columns; their methods and results, although now seeming rude and defective, are deserving of praise as the first of real practical value.

In 1849 was published the 'Report of the Commissioners on the Application of Iron to Railway Structures', which may be regarded as the landmark of the beginning of modern methods of testing. It contains the records of valuable tests by Willis, James, Hodgkinson, and Galton on the strength of cast and wrought iron as well as upon the resistance to impact, investigations of the increase in stress caused by a rolling load on a beam, experiments on the fatigue of metals, and the evidence given by leading British engineers as to their opinions on proper factors of safety under different conditions. The immediate result of this report was the decision by the English board of trade that the factor of safety for cast iron should be twice as great for rolling loads as for steady ones, while throughout both Europe and the United States it excited a marked interest and impetus in the subject of testing materials.

The first testing machines in the United States were those built by Wade and Rodman between 1850 and 1860 for testing gun-metal for the government. About this time the rapid introduction of iron bridges led to experiments by Plympton and by Roebling. Prior to 1865 apparatus was built by each experimenter for his special work, but in this year Fairbanks put upon the market the first testing machines for commercial work. A little later the machines of Olsen and of Riehlé for tensile, compressive, and flexural tests were introduced and have since been widely used. The machine devised by Emery, soon after 1875, is a very precise apparatus which is used in large laboratories. Large machines for testing eye-bars have been built by bridge companies since 1880, and numerous testing laboratories now contain machines for every kind of work.

The capacity of a testing machine is the tension or pressure which it can exert. A small machine for testing cement by

tension has usually a capacity of 1 000 or of 2 000 pounds. Machines of 50 000, 100 000, and 150 000 pounds for testing metals are common. The Emery machine at the government arsenal at Watertown, Mass., has a capacity of 1 000 000 pounds, and it can test a bar 30 feet long or a small hair with equal precision. The eye-bar machine at Athens, Pa., has a capacity of 1 244 000 pounds, and that at Phoenixville, Pa., a capacity of 2 160 000 pounds. It forms no part of the purpose of this book to give descriptions and illustrations of these machines; Martens' Handbook for Testing Materials (Berlin, 1898; New York, 1899) may be referred to as giving thorough and comprehensive discussions of both testing machines and of methods of testing.

Tensile tests are the most common and some commercial machines are arranged with an autographic recording apparatus whereby a card is secured which shows the relation between the load and the elongation throughout the test. There are also a number of autographic recording devices in the market, which may be attached to any machine. When such a graphic record is taken, the yield point, ultimate strength, and ultimate elongation may be read from it. Nearly all tensile machines may be also used for compressive tests, and also for flexural tests on short beams. The smaller machines are operated by hand, while power is required to run the larger ones. Screw machines in which the load is brought upon the specimen by the help of large screws are generally preferred in the United States, while hydraulic machines in which a hydraulic press is used to transmit the load to the specimen are preferred in Europe. The machine of Emery is hydraulic; other American makes are screw machines.

Commercial tests of materials are rarely made under shearing and torsional stresses. Thurston in 1870 devised a torsion machine for small specimens, and the torsion machines of Olsen and of Riehlé, which are found in the laboratories of most engineering colleges, prove very serviceable for illustrating the phenomena of twisting. Impact machines have been built for special investigations, but the only one on the market is that of Keep which is designed for tests of bars of cast iron. Fatigue or

endurance tests, which subject the specimens to alternating stresses for long periods of time, have not been made except in laboratories.

The testing of materials has assumed such great importance since 1890 that all engineering colleges have provided laboratories for the purposes of instruction and research. The work done by some of these has proved of much value to the engineering profession; the work of Hatt on impact tests of metals and that of Talbot on reinforced-concrete beams may be cited as examples. Manufacturers of iron and steel, and large railroad companies, have installed laboratories for the testing of their products and purchases, several of these having a machine of 300 000 pounds capacity as well as smaller ones. The many series of tests conducted by Howard at the Watertown arsenal may be mentioned as part of the valuable work done by the government of the United States. The largest testing laboratories, however, are found in Europe, that at Berlin, under the directorship of Martens, standing at the head; this has a floor area of 10 360 square meters or about $2\frac{1}{2}$ acres.

Prob. 168. Consult Das königliche Materialprüfungsamt der technischen Hochschule, Berlin, 1904, and ascertain the various kinds of work done in that great laboratory.

ART. 169. TESTING OF MATERIALS

The specimens for tensile tests are either flat or round. A flat specimen is rarely used except for plates, and its standard size is 18 inches in length, 2 inches wide along the ends and $1\frac{1}{2}$ inches wide for a central length of about 9 inches, while the thickness is the same as that of the plate from which it is cut. Wire and rods are frequently tested just as they come from the mill, the length between the jaws of the machine being usually more than ten times the diameter. Standard round specimens are cut from axles, shafts, beams, and other manufactured products. Prior to 1895 the standard size of the round specimen was 1 inch in diameter along a central length of 9 inches, while the ends were larger and provided with screw threads. Both

flat and round specimens are frequently called 8-inch specimens because two marks are placed upon them 8 inches apart for the purpose of measuring the elongation. Since 1895 there has been gradually coming into use in the United States a smaller size for round specimens which is shown in Fig. 169*a*; this is called the 2-inch specimen, because the central part is a little more than 2 inches long and the marks are placed upon it 2 inches apart; the diameter of this specimen is 0.5 inch or sometimes 0.505 inches. This smaller specimen has the advantage that less material is required to be wasted in taking it from an axle or shaft, but it has the disadvantage that percentages of elongation computed from it are greater than those determined from the 8-inch specimen (Art. 25). In Art. 12 will be found a description of the tests of these 2-inch specimens.

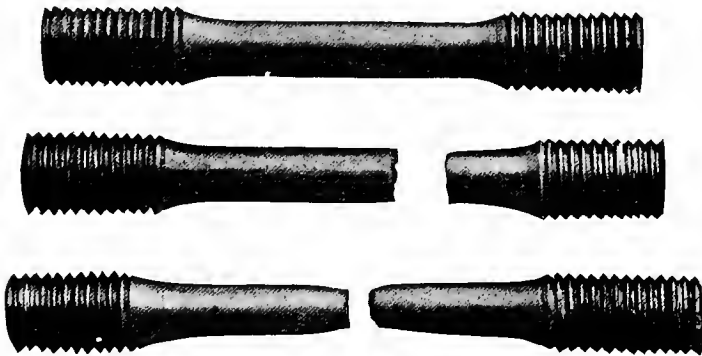

Fig. 169*a*

Flat specimens are usually gripped by the jaws of the machine, while the standard round specimens screw into nuts to which the tension is applied. The load transmitted through the specimen is weighed by a scale at the end of a compound lever. In commercial tests the ultimate elongation is alone measured; this is done by two marks on the specimen and measuring the distance between them before and after rupture. In scientific tests an extensimeter is attached to the specimen, so that the elongation can be read at each increment of weight. The elonga-

tion is usually expressed as a percentage of the original length between the two marks on the specimen, and for the reason above stated it is always desirable that the original length and the diameter of specimen should be mentioned in the report. For ductile materials, like wrought iron and mild steel, it is customary to slowly reduce the load after the ultimate strength is reached; the material is then flowing rapidly, so that the elongation continues to increase, and hence a greater percentage of elongation is obtained.

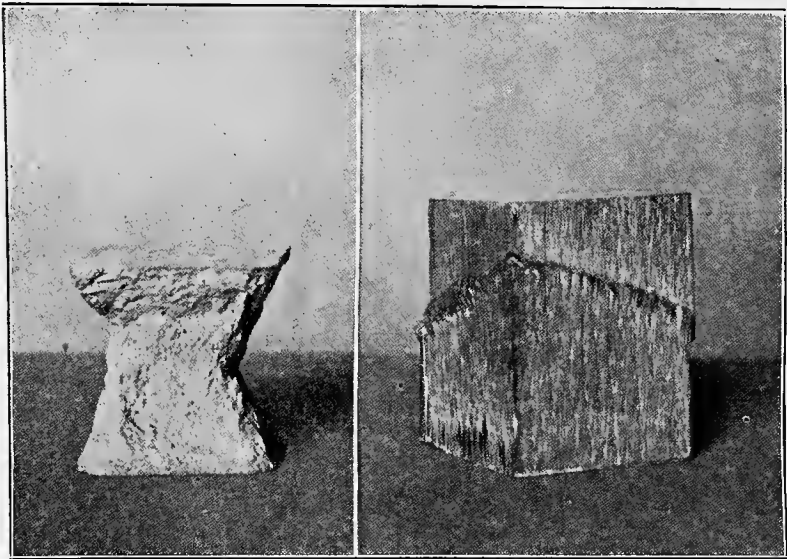

Fig. 169b

Compressive tests are mainly confined to brick, stone, and concrete, and are but little used for metals on account of the expense of preparing the specimens with truly parallel sides. Since these specimens are short, it is difficult to obtain precise measures of the change of length; the ultimate shortening is rarely observed, because it is difficult to note the moment when it occurs. Failure in the case of brittle materials occurs by a diagonal shearing as explained in Arts. 18 and 147. Fig. 169b shows a cube of neat cement and a timber block which have

failed in this manner; the section area of each of these specimens is 2×2 inches.

In flexural tests the load is usually applied at the middle of a beam supported at its ends and gradually increased until rupture occurs, the deflection being measured also as a test of stiffness. The apparatus for determining the deflection should be attached to the supports so that the compression of these may not affect the observed values. In the simplest case weights are hung upon a ring or stirrup placed upon the middle of a simple beam, and are added in regular increments of 100 pounds, more or less, depending upon the size of the beam. When the elastic limit is not exceeded the modulus of elasticity E may be computed from the observed deflection by the formula deduced in Art. 55. From the breaking load P , the flexural strength or modulus of rupture S_r may be computed from the flexure formula (41); this lies between the ultimate tensile and compressive strengths of the material, and although not a physical constant (Art. 52) it is useful for comparing different qualities of the same material.

Torsion tests are not used for commercial purposes, but in scientific laboratories much has been learned by the use of torsion machines. Fig. 169c shows three specimens which have been subjected to torsion, the first being a square steel bar which broke at the upper end, the second a round bar of cast iron, and the third a rectangular steel bar which was ruled with white lines in order that the distortions might be studied; discussions of these experiments are given in Arts. 94 and 99.

Impact tests are regarded as of much value in judging of the quality of ductile metals. The cold-bend test, briefly described in Art. 24, is one that has been known from the earliest times and which is constantly used in all mills where wrought iron or steel is produced. The bending of the specimen is generally done by blows of a hammer, although steady pressure is sometimes employed. Notwithstanding that no numerical results are obtained from the cold-bend test, except the final angle of bending, the general information that it gives is of the highest

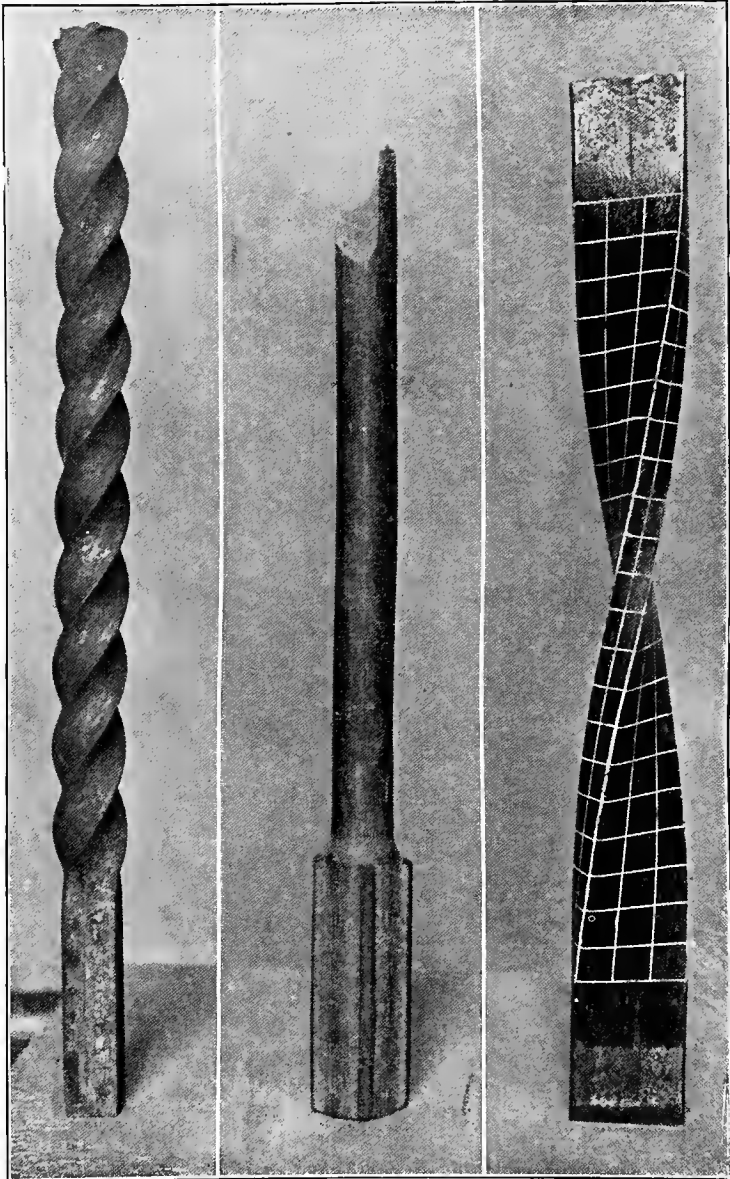

Fig. 169c

importance, so that it has been said that, if all tests of metals except one were to be abandoned, the cold-bend test should be the one to be retained. In the rolling-mill it is used to judge of the purity and quality of the muck bar; in the steel mill it serves to classify and grade the material almost as well as chemical analysis can do, and in the purchase of shape iron it affords a quick and satisfactory method of estimating toughness, ductility, strength, and capacity to resist external work.

It is very important, in order that the results of tests made in different laboratories may be compared and correct conclusions be drawn therefrom, that the methods of testing shall be uniform. In 1882 a number of German professors met at Munich to discuss this question, and other conferences were held in 1884, 1886, 1888, and 1893, at which engineers from other European countries were present. In 1895 the International Association for Testing Materials was formally organized at Zurich, its object being "the development and unification of standard methods of testing for the determination of the properties of materials, and also the perfection of apparatus for that purpose." The second Congress of the Association met at Stockholm in 1897, the third at Budapest in 1902, and the fourth at Brussels in 1905, these being attended by representatives of about twenty different countries. Affiliated with the International Association are several national societies which are engaged in the same work. The American Section of the International Association, organized in 1898, became in 1901 the American Society for Testing Materials. The number of members of the International Association at the beginning of 1905 was 2215, representing 24 different countries; of these, 580 members were in the United States, 367 in Germany, 357 in Russia, 193 in Austria, 154 in France. The official organ of the International Association is the journal *Baumaterialienkunde*, published semi-monthly at Stuttgart, Germany. The American Society for Testing Materials published the fifth volume of its Proceedings in 1905.

Prob. 169. Refer to Hatt and Marburg's Bibliography of Impact Tests and Impact Testing Machines, published in Vol. II of the Pro-

ceedings of the American Society for Testing Materials; consult several references and describe one or more machines for making impact tests.

ART. 170. RULES FOR TESTING

When materials or manufactured products are to be purchased, the requirements that they must fulfill are generally expressed in 'specifications'. If it is specified that certain tests are to be made, or certain test specimens be used, it is necessary that this should be done most carefully, and no deviation from the given requirements can be allowed. Full specifications regarding machines and methods of testing are, however, rarely made by a purchaser, so that considerable latitude is allowed, but in all cases it should be the aim of the engineer in charge of the tests to so conduct the work that it shall be well and truly done. Certain general rules regarding testing machines and their use will hence be given here, and the observance of these as far as practicable will conduce to uniformity of methods and to reliability of the results, these rules applying mainly to machines for common tensile tests.

1. A machine should be so constructed that the load borne by the specimen alone is registered upon the weighing scale, so that its readings may not include any force expended in friction on the pivots or moving parts of the machine.

2. A machine should be from time to time rated or calibrated, to ascertain if the readings of the weighing scale are correct, or that the errors of its readings may be known.

3. The construction of the machine should be such that, when properly operated, the specimens may not be subject to shock.

4. The holders or jaws which gripe the ends of a tensile specimen should be so arranged that the resultant load coincides with the axis of the specimen, in order that the stress may be uniformly distributed over the section area.

5. The use of serrated wedges for holding the ends of specimens is not advisable unless those ends are larger in section area than the main part of the specimen.

6. The load upon specimens of ductile materials should be applied at a slower rate within the elastic limit than after that limit is passed.

7. When the elastic limit is specified, this is not to be determined by the drop of the scale beam, but by measuring the increments of elongation corresponding to increments of the load; the drop of the beam indicates the yield point.

8. Percentages of elongation should be accompanied by a statement of the size of the test pieces from which they were determined.

Many other rules have been proposed, but it is believed that the above are nearly all which will be universally accepted as essential ones in tensile tests. For compressive tests the following may be noted as desirable requirements:

9. The surfaces to which the pressure is applied should be truly parallel, in order that the stress may be uniformly distributed over the section area; this distribution will be more perfect if one of the supports is arranged so as to be movable in all directions.

10. The cube is probably the best form of compression specimen, because it has been so widely used that the results of tests are better comparable with previous records than if prisms are used.

For flexural tests it is not so easy to state definite rules, but it will be generally admitted that the supports should be rounded, so as not to indent the beam or prevent the ends from taking the inclination of the theoretic elastic curve. When deflections are measured, the apparatus should be attached to the ends of the beam, if any yielding of the supports can occur. In all static tests of tension, compression, or flexure, it should be the aim to secure measurements which can be relied upon as correct with a probable error not exceeding one-half of one percent.

Impact tests of rails, axles, and car-wheels are usually made by a simple apparatus which consists of a ram falling between guides. It is here important that the guides should not retard the fall of the ram, that the shape of the ram should be such as to prevent lateral oscillation, that the surface struck should

be level, that the weight of the supports of the specimen should be at least ten times that of the ram, and that these supports should rest upon masonry.

In conclusion it may be noted that all the theoretic discussions of this volume are of assistance in conducting tests of materials. When a tensile test is to be made, it must not be forgotten that reliable results cannot be obtained unless the specimen is placed in the machine in such a manner that there is no tendency to flexure; when a compressive test is to be made, the influence of an eccentric load should be kept in mind; when a flexural test is to be made, the theory of flexure should be understood. Clear and definite ideas regarding elastic limit and yield point will avoid misunderstanding. Theory and practice should always go hand in hand, each supplementing and explaining the other.

Prob. 170. Consult a paper by Goss in Vol. III of Proceedings of American Society for Testing Materials, and describe the drop testing machine of the Master Car Builders' Association.

ART. 171. SPECIFICATIONS FOR STRUCTURAL STEEL

When materials are to be purchased, a set of rules is usually prepared giving requirements regarding quality and tests, and these rules are called 'specifications'. There is much variation in such specifications owing to the different opinions of buyers and the use which is to be made of the material. The following specifications for structural steel will give the student an idea of the extent and scope of the requirements which are generally demanded for steel to be used in buildings, bridges, and ships. The order of arrangement is similar to that of the specifications adopted by the American Society for Testing Materials and the American Railway Engineering and Maintenance of Way Association, but the requirements differ in a few particulars.

1. Structural steel shall be made by the open-hearth process.
2. Each of the three classes of structural steel shall conform to the following limits in chemical composition: Sulphur shall not exceed 0.06 percent; Phosphorus shall not exceed 0.07 per-

cent when the steel is made by the acid process and not exceed 0.04 percent when it is made by the basic process.

3. There shall be three classes of structural steel for bridges and ships, namely, rivet steel, soft steel, and medium steel, which shall conform to the following physical requirements: Rivet steel shall range in tensile strength from 50 000 to 55 000 pounds per square inch, have a yield point not less than 33 000 pounds per square inch, and the elongation in 8 inches shall not be less than 26 percent. Soft steel shall range in tensile strength from 55 000 to 60 000 pounds per square inch, have a yield point not less than 35 000 pounds per square inch, and the elongation in 8 inches shall not be less than 25 percent. Medium steel shall range in tensile strength from 60 000 to 65 000 pounds per square inch, have a yield point not less than 37 000 pounds per square inch, and the elongation in 8 inches shall not be less than 23 percent.

4. For each increase of $\frac{1}{8}$ inch in a flat specimen above a thickness of $\frac{3}{4}$ inches, a deduction of 1 shall be made from the above specified elongation. For each decrease of $\frac{1}{16}$ inch below a thickness of $\frac{5}{16}$ inches, a deduction of $2\frac{1}{2}$ shall be made from the above specified elongation. For bridge pins the required elongation shall be 5 less than that above specified, as determined on a test specimen the center of which shall be one inch from the surface of the pin.

5. Eye-bars shall be of medium steel. Full-sized tests shall show $12\frac{1}{2}$ percent elongation in 15 feet of the body of the eye-bar, and the tensile strength shall not be less than 55 000 pounds per square inch. Eye-bars shall be required to break in the body, but should an eye-bar break in the head, and show $12\frac{1}{2}$ percent elongation in 15 feet and the tensile strength specified, it shall not be cause for rejection, provided that not more than one-third of the total number of eye-bars tested break in the head.

6. The three classes of structural steel shall conform to the following bending tests; and for this purpose the test specimen shall be $1\frac{1}{2}$ inches wide, if possible, and for all material $\frac{3}{4}$ inches or less in thickness the test specimen shall be of the same thick-

ness as that of the finished material from which it is cut, but for material more than $\frac{3}{4}$ inches thick the bending test specimen may be $\frac{1}{2}$ inch thick:

Rivet steel shall bend cold 180 degrees flat on itself without fracture on the outside of the bent portion. Rivet rounds shall be tested of full size as rolled.

Soft steel shall bend cold 180 degrees flat on itself without fracture on the outside of the bent portion.

Medium steel shall bend cold 180 degrees around a diameter equal to the thickness of the specimen tested, without fracture on the outside of the bent portion.

7. The standard test specimen of 8 inches gauged length shall be used to determine the physical properties specified in paragraphs Nos. 3 and 4. The standard size of the test specimen for sheared plates shall be $1\frac{1}{2}$ inches in width for a length not less than 9 inches, and of a thickness equal to that of the plate. For other material the test specimen may be the same as for sheared plates or it may be planed or turned parallel throughout its entire length, and in all cases where possible two opposite sides of the test specimen shall be the rolled surfaces. Rivet rounds and small rolled bars shall be tested of full size as rolled.

8. One tensile test specimen shall be taken from the finished material of each melt or blow, but in case this develops flaws, or breaks outside of the middle third of its gauged length, it may be discarded and another test specimen substituted therefor.

9. One test specimen for bending shall be taken from the finished material of each melt as it comes from the rolls, and for material $\frac{3}{4}$ inches and less in thickness this specimen shall have the natural rolled surface on two opposite sides. The bending-test specimen shall be $1\frac{1}{2}$ inches wide, if possible, and for material more than $\frac{3}{4}$ inches thick the bending-test specimen may be $\frac{1}{2}$ inch thick. The sheared edges of bending-test specimens may be milled or planed.

10. Material which is to be used without annealing or further treatment shall be tested for tensile strength in the condition in

which it comes from the rolls. Where it is impracticable to secure a test specimen from material which has been annealed or otherwise treated, a full-sized section of tensile-test specimen length shall be similarly treated before cutting the tensile-test specimen therefrom.

11. For the purpose of this specification, the yield point shall be determined by careful observation of the drop of the beam or halt in the gauge of the testing machine.

12. In order to determine if the material conforms to the chemical limitations prescribed in paragraph No. 2 herein, analysis shall be made of drillings taken from a small test ingot.

13. The variation in cross-section or weight of more than $2\frac{1}{2}$ percent from that specified will be sufficient cause for rejection, except in the case of sheared plates, which will be covered by the following permissible variations:

Plates $12\frac{1}{2}$ pounds per square foot or heavier, up to 100 inches wide, when ordered to weight, shall not average more than $2\frac{1}{2}$ percent variation above or below the theoretical weight. When 100 inches wide and over, 5 percent above or 5 percent below the theoretical weight.

Plates under $12\frac{1}{2}$ pounds per square foot, when ordered to weight, shall not average a greater variation than the following: When less than 75 inches wide, $2\frac{1}{2}$ percent above or below the theoretical weight. When 75 inches wide up to 100 inches wide, 5 percent above or 3 percent below the theoretical weight. When 100 inches wide and over, 10 percent above or 3 percent below the theoretical weight.

When plates are ordered to gauge, a variation of more than $\frac{1}{16}$ inch below that specified for any dimension will be sufficient cause for rejection. An excess in weight above the nominal weight may, however, be allowed, as agreed upon between the inspector and the manufacturer.

14. Finished material must be free from injurious seams, flaws, defective edges, or cracks, and have a workmanlike finish.

15. Every finished piece of steel shall be stamped with the

melt number, and steel for pins shall have a melt number stamped on the ends. Rivets and lacing steel, and small pieces for pin plates and stiffeners, may be shipped in bundles, securely wired together, with the melt number on a metal tag attached.

16. The inspector representing the purchaser, shall have all reasonable facilities afforded to him by the manufacturer to satisfy him that the finished material is furnished in accordance with these specifications. All tests and inspections shall be made at the place of manufacture, prior to shipment.

Prob. 171. Consult Proceedings of the American Society for Testing Materials, Vol. IV, 1904, and ascertain the tests recommended by Webster for detecting brittle steel. Young men should also read the excellent advice given in Vol. V of the same Proceedings by President Dudley in his address on the duties and responsibilities of the testing and inspecting engineer.

CHAPTER XIX

MATHEMATICAL THEORY OF ELASTICITY

ART. 172. INTRODUCTION

The mathematical theory of elasticity is that science which treats of the behavior of bodies under stress when the law of proportionality of deformation to stress is observed. All the theoretic formulas of the preceding pages have been derived by the help of this law, but these constitute only a part of the mathematical theory of elasticity. The formulas derived for the deformation of bodies under tension or compression suppose the bodies to be homogeneous or isotropic, so that the modulus of elasticity E is the same for all directions; some materials, however, have different properties of stiffness in different directions so that there may be several values of E to be considered, this being especially the case with crystals. The theory of elasticity takes account of such non-homogeneous structure and deduces formulas for the deformations due to forces applied in different directions. In this chapter only the elements of this theory can be given, and in general the bodies under stress will be regarded as homogeneous. The complete theory deals not only with elastic solids, but with fluids, gases, and the ether of space, while the discussion of stresses and deformations, both in homogeneous and crystalline bodies, leads to the investigation of wave propagations, the time and velocity of elastic oscillations, and numerous other phenomena of physics.

Statics proper is concerned only with rigid bodies, while the theory of elasticity deals with bodies deformed under the action of exterior forces and which recover their original shape on the removal of these forces. All the principles and methods of statics apply in the discussion of elastic bodies, but in addition new principles based upon Hooke's law arise. The amount of deformation being small within the elastic limit for common

materials, it is allowable to neglect the squares and higher powers of a unit-elongation in comparison with the elongation itself, as set forth in Art. 13. By the help of this principle, the elastic change in volume of a body may be found (Art. 173), the modulus of elasticity for tension or compression is found to have a certain relation to the modulus of elasticity for shearing (Art. 181), and a new modulus of elasticity based on change in volume is introduced (Art. 182).

The general case of a body acted upon by forces in several directions occupies the main part of this chapter, this case requiring the use of three rectangular coordinates. This chapter, then, is an extension of the methods of Chapters XI and XV, and includes those methods as special cases. It has been prepared from the point of view of the engineer rather than that of the pure mathematician, and should be regarded only as an introduction to the mathematical theory of elasticity.

The student should consult the article on Elasticity by Kelvin in the *Encyclopædia Britannica*, as also the *History of Todhunter and Pierson*. The works of Clebsch (*Elasticität fester Körper*, 1862), Winkler (*Elasticität und Festigkeit*, 1867), Grashof (*Theorie der Elasticität und Festigkeit*, 1878), and Flamant (*Résistance des Matériaux*, 1886) may be mentioned as treating the subject both from the theoretical and the engineering point of view.

Prob. 172. Consult Todhunter and Pierson's *History of the Theory of Elasticity and of the Strength of Materials*, and ascertain something about the important investigations of Saint Venant.

ART. 173. ELASTIC CHANGES IN VOLUME

The changes in section area and in volume which occur when a bar is under axial stress have been discussed in Art. 13, and the same method will now be applied to the case of a body acted upon by forces in different directions. When the elastic limit of the material is not surpassed, the deformation due to any applied force is proportional to that force for deformations in any and all directions, and the principles of Art. 139 enable these to be determined.

The simplest case is that shown in Fig. 173, where a parallelo-
 piped is acted upon by the tensile unit-forces S_1, S_2, S_3 in three
 rectangular directions. The body is regarded as homogeneous,
 so that the factor of lateral contraction λ and the modulus of
 elasticity E are the same in all directions. Let ϵ_1 be the unit-
 elongation due to S_1 or $\epsilon_1 = S_1/E$, also $\epsilon_2 = S_2/E$ and $\epsilon_3 = S_3/E$.
 Then the actual unit-elongations which take place in the three
 rectangular directions are given by,

$$\epsilon' = \epsilon_1 - \lambda\epsilon_2 - \lambda\epsilon_3 \qquad \epsilon'' = \epsilon_2 - \lambda\epsilon_3 - \lambda\epsilon_1 \qquad \epsilon''' = \epsilon_3 - \lambda\epsilon_1 - \lambda\epsilon_2$$

Now for any cube of edge unity, the volume after the application
 of the unit-forces S_1, S_2, S_3 is $(1 + \epsilon')(1 + \epsilon'')(1 + \epsilon''')$, and since
 $\epsilon', \epsilon'', \epsilon'''$ are small compared with unity, this product is
 $1 + \epsilon' + \epsilon'' + \epsilon'''$ (Art. 13). Accordingly, the elastic change in
 the unit of volume is,

$$\epsilon' + \epsilon'' + \epsilon''' = (1 - 2\lambda)(\epsilon_1 + \epsilon_2 + \epsilon_3) = (1 - 2\lambda)(S_1 + S_2 + S_3)/E \quad (173)$$

Here it is seen that there is no change in volume when $\lambda = \frac{1}{2}$.
 For all the materials of construction it is found that the factor
 of lateral contraction is less than $\frac{1}{2}$, so that they increase in volume
 under tension and decrease under compression.

In the above discussion the unit-forces S_1, S_2, S_3 are regarded
 as tensile, but the formula for change of volume applies equally
 well when one or all of them are compressive; for example, if
 S_1 is tension and S_2 and S_3 are compression, the values of S_2
 and S_3 are to be taken as negative. The above formula refers
 to unit of volume and the actual change in a paralleloiped of

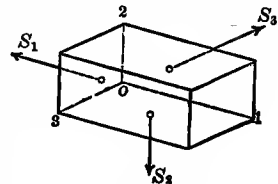

Fig. 173

given dimensions is found by multiplying
 the unit-change by the number of units
 of volume in the body. For example, let
 a brick $2 \times 4 \times 8$ inches be subjected to a
 compression of 12 800 pounds upon the
 two flat sides, to a compression of 48 000
 pounds upon the two narrow sides, and
 to a tension of 1 600 pounds upon the two ends. Here $S_1 =$
 $-12800/32 = -400$, $S_2 = -4800/16 = -300$, and $S_3 = +1600/8$
 $= +200$ pounds per square inch; then $S_1 + S_2 + S_3 = -500$
 pounds per square inch. Taking $\lambda = 0.2$, and $E = 2\,000\,000$

pounds per square inch, the change per unit of volume is found to be -0.0002 , so that the decrease in the volume of the parallelepiped is $0.0002 \times 64 = 0.0128$ cubic inches.

Elastic changes in section area due to the action of several forces are readily expressed in a similar manner. For instance, in the unit cube let a plane be drawn normal to S_1 cutting out a square; its area after the application of the three forces is $(1 + \epsilon'')(1 + \epsilon''')$, which is equal to $1 + \epsilon'' + \epsilon'''$. Hence the change per unit of section area is found from (173) by making ϵ' and S_1 equal to zero. Thus, for the above numerical example, the change per unit of section area normal to S_1 is -0.00004 , so that the decrease in this section area is $0.00004 \times 8 = 0.00032$ square inches.

When a body is under uniform compression in all directions, as is the case when it is subjected to fluid pressure, the unit-stresses S_1, S_2, S_3 are equal, as also the unit-deformations $\epsilon_1, \epsilon_2, \epsilon_3$. For this case the change per unit of length is the same in all directions and equal to $(1 - 2\lambda)\epsilon$, the change per unit of area in any section is $2(1 - 2\lambda)\epsilon$, and the change per unit of volume is $3(1 - 2\lambda)\epsilon$, where ϵ is the unit-change S/E which would be caused by an axial unit-stress S which is equal to the uniform compressive unit-stress. The change in section area is hence double, and the change in volume is three times that in a linear dimension.

Prob. 173. Make experiments upon india rubber with the intention of finding the value of the factor of lateral contraction for that material.

ART. 174. NORMAL AND TANGENTIAL STRESSES

The general case of internal stress is that of an elementary parallelepiped held in equilibrium by apparent stresses applied to its faces in directions not normal. Here each oblique stress may be decomposed into three components parallel respectively to three coordinate axes, OX, OY, OZ . Upon each of the faces perpendicular to OX the normal component of the oblique unit-stress is designated by S_x and the two tangential components

by S_{xy} and S_{xz} . A similar notation applies to each of the other faces. An S having but one subscript denotes a tensile or compressive unit-stress, and its direction is parallel to the axis corresponding to that subscript. An S having two subscripts denotes a shearing unit-stress, the first subscript designating the axis to which the face is perpendicular and the second designating the axis to which the stress is parallel; thus S_{zx} is on the face perpendicular to OZ and its direction is parallel to OX . In Fig. 174 the nine components for three sides of the parallelepiped are shown. Neglecting the weight of the parallelepiped the components upon the three opposite sides must be of equal intensity in order that equilibrium may obtain.

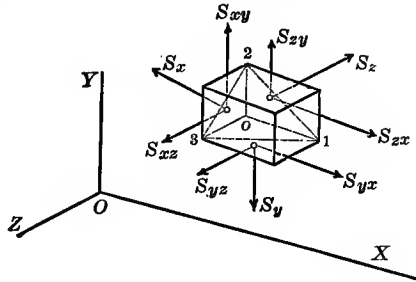

Fig. 174

An elementary parallelepiped in the interior of a body is thus held in equilibrium under the action of six normal and twelve tangential stresses acting upon its faces. The normal stresses upon any two opposite faces must be equal in intensity and opposite in direction. The tangential stresses upon any two opposite faces must also be equal in intensity and opposite in direction.

A certain relation must also exist between the six shearing stresses shown in Fig. 174 in order that equilibrium may obtain. Let the parallelepiped be a cube with each edge equal to unity; then if no tendency to rotation exists with respect to an axis through the center of the cube and parallel to OX it is necessary that S_{yz} should equal S_{zy} . A similar condition obtains for each of the other rectangular axes, and hence,

$$S_{xy} = S_{yx} \quad S_{yz} = S_{zy} \quad S_{zx} = S_{xz} \quad (174)$$

that is, those shearing unit-stresses are equal which are upon any two adjacent faces and normal to their common edge.

The apparent unit-stresses designated by S are computed by

the methods of the preceding chapters; it is rare, however, that more than three or four of them exist, even under the action of complex forces. The general problem is then to find a parallelepiped such that the resultant stresses upon it are wholly normal. These resultant normal stresses will be S_1, S_2, S_3 , from which by (139) the true normal stresses T_1, T_2, T_3 can be found. It will later be shown that these stresses S_1, S_2, S_3 are the maximum apparent stresses of tension or compression resulting from the given normal and tangential stresses.

Prob. 174. Let a, b, c be the angles which a line makes with the axes OX, OY, OZ , respectively. Show that the sum of the squares of the cosines of these angles is equal to unity.

ART. 175. RESULTANT STRESSES

The resultant unit-stress upon any face of the parallelepiped in Fig. 174 is the resultant of the three rectangular unit-stresses acting upon that face. Thus for the face normal to the axis OZ the resultant unit-stress is given by,

$$R_3^2 = S_x^2 + S_{zx}^2 + S_{zy}^2$$

and the total resultant stress upon that face of the parallelepiped is the product of its area and R_3 .

The resultant unit-stress R upon any elementary plane having any position can be determined when the normal and tangential stresses in the directions parallel to the coordinate axes are known. Let a plane be passed through the corners 1, 2, 3, of the parallelepiped in Fig. 174, and let a, b, c be the angles that its normal makes with the axes OX, OY, OZ , respectively. Let α, β, γ , be the angles which the resultant unit-stress R makes with the same axes. Let A be the area of the triangle 1 2 3; then the total resultant stress upon that area is AR , and its components parallel to the three axes are $AR \cos \alpha, AR \cos \beta, AR \cos \gamma$. The triangle whose area is A , together with the three triangles $o 2 3, o 1 3, o 1 2$, form a pyramid which is in equilibrium under the action of R and the stresses upon the three triangles. The areas of these triangles are $A \cos a, A \cos b, A \cos c$, and the stresses upon them

are the products of the areas by the several unit-stresses. Now the components of these four stresses with respect to each rectangular axis must vanish as a necessary condition of equilibrium. Hence, canceling out A , which occurs in all terms, there results,

$$\begin{aligned} R \cos\alpha &= S_x \cos a + S_{xy} \cos b + S_{xz} \cos c \\ R \cos\beta &= S_{xy} \cos a + S_y \cos b + S_{zy} \cos c \\ R \cos\gamma &= S_{xz} \cos a + S_{yz} \cos b + S_z \cos c \end{aligned} \quad (175)$$

in which the second members are all known quantities.

From these equations the values of $R \cos\alpha$, $R \cos\beta$, $R \cos\gamma$ can be computed; then the sum of the squares of these is R^2 since $\cos^2\alpha + \cos^2\beta + \cos^2\gamma = 1$. The value of $\cos\alpha$ is found by dividing that of $R \cos\alpha$ by R , and similarly for $\cos\beta$ and $\cos\gamma$. Now the angle θ between the directions of R and the normal to the plane is given by,

$$\cos\theta = \cos a \cos\alpha + \cos b \cos\beta + \cos c \cos\gamma$$

and then the tensile or compressive unit-stress normal to the given plane is $R \cos\theta$, while the resultant shearing unit-stress is $R \sin\theta$. This shearing stress may be resolved into two components in any two directions on the plane.

As a simple numerical example, let a bolt be subject to a tension of 12 000 pounds per square inch and also to a cross-shear of 8 000 pounds per square inch. It is required to find the apparent unit-stresses on a plane making an angle of 60 degrees with the axis of the bolt. Take OX parallel to the tensile force and OY parallel to the cross-shear. Then $S_x = +12\,000$, $S_{xy} = 8\,000$, $S_{yx} = 8\,000$, and the other stresses are zero; also $a = 30^\circ$, $b = 60^\circ$, and $c = 90^\circ$. Then from (175),

$$R \cos\alpha = +14\,390 \quad R \cos\beta = +6\,930 \quad R \cos\gamma = 0$$

and the resultant stress on the given plane is,

$$R = (14\,390^2 + 6\,930^2)^{\frac{1}{2}} = 15\,970 \text{ pounds per square inch}$$

The direction made by R with the axis is now found:

$$\begin{aligned} \cos\alpha &= 14390/15970 = 0.901 & \alpha &= 64\frac{1}{4}^\circ \\ \cos\beta &= 6930/15970 = 0.434 & \beta &= 25\frac{3}{4}^\circ \end{aligned}$$

and the angle included between the resultant R and the normal

to the given plane is computed by,

$$\cos\theta = 0.866 \times 0.901 + 0.5 \times 0.434 = 0.997$$

Lastly, the normal tensile stress on the plane is found to be $R \cos\theta = 15\,920$ pounds per square inch, while the shearing stress on the plane is $R \sin\theta = 1\,200$ pounds per square inch.

Prob. 175. Find for the above example the position of a plane upon which there is no shearing stress.

ART. 176. THE ELLIPSOID OF STRESS

Let the resultant unit-stress R upon any plane passing through a given point in the interior of a stressed body make an angle θ with the normal to that plane. It will now be shown that, for different planes through the given point, the intensity of R may be represented by the radius vector of an ellipsoid.

Let R_1, R_2, R_3 be the resultant unit-stresses upon the three faces of the parallelepiped in Fig. 174, and let $\theta_1, \theta_2, \theta_3$ be the angles which they make with the coordinate axis OX ; then,

$$\cos\theta_1 = S_x/R_1 \quad \cos\theta_2 = S_{yx}/R_2 \quad \cos\theta_3 = S_{zx}/R_3$$

determine the directions of R_1, R_2, R_3 . Now let these directions be taken as those of a new system of oblique coordinate axes, let R be the resultant unit-stress in any direction, and let R_x, R_y, R_z be its components parallel to these new axes. Then $R \cos\alpha$ is the component of R parallel to OX , and,

$$R \cos\alpha = R_x \cos\theta_1 + R_y \cos\theta_2 + R_z \cos\theta_3$$

or, inserting for the cosines their values, it becomes,

$$R \cos\alpha = S_x(R_x/R_1) + S_{yx}(R_y/R_2) + S_{zx}(R_z/R_3)$$

Comparing this with the first equation in (175), it is seen that,

$$\cos a = R_x/R_1 \quad \cos b = R_y/R_2 \quad \cos c = R_z/R_3$$

But the sum of the squares of these cosines is unity; hence,

$$(R_x/R_1)^2 + (R_y/R_2)^2 + (R_z/R_3)^2 = 1$$

in which the numerators are variable coordinates and the denominators are given quantities. This is the equation of the surface of an ellipsoid with respect to three coordinate axes having the directions of R_1, R_2, R_3 .

The surface of an ellipsoid is hence a figure whose radius vector represents the resultant unit-stress upon a plane the normal to which makes an angle θ with the direction of that radius vector. If the forces are entirely confined to one plane, the ellipsoid reduces to an ellipse.

If there are three planes at right angles to each other which are subject only to normal stresses, as in Fig. 176, the normal unit-stresses S_x, S_y, S_z correspond to R_1, R_2, R_3 in the above equation of the ellipsoid. In this case S_x, S_y, S_z are the three axes of the ellipsoid. If now shearing stresses are applied to the faces, the ellipsoid will be deformed, and the three axes will take other positions corresponding to three planes upon which no shearing stresses act. The stresses corresponding to the axes of the ellipsoid are called principal stresses.

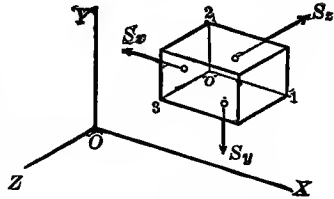

Fig. 176

Prob. 176. If $S_y = S_z$ in Fig. 175, show that the ellipsoid becomes either a prolate spheroid or an oblate spheroid.

ART. 177. THE THREE PRINCIPAL STRESSES

In general, the resultant unit-stress R upon a given plane makes an angle θ with the normal to that-plane, and hence can be resolved into a normal stress of tension or compression and into two tangential shearing stresses (Art. 174). It is evident, however, that planes may exist upon which only normal stresses act, so that θ is zero and R is pure tension or compression. In order to find these planes and the stresses upon them, the angles α, β, γ in the equations (175) are to be made equal to a, b, c , respectively. Also replacing R by S , these equations become,

$$\begin{aligned} (S - S_x) \cos a &= S_{yx} \cos b + S_{zx} \cos c \\ (S - S_y) \cos b &= S_{xy} \cos a + S_{zy} \cos c \\ (S - S_z) \cos c &= S_{xz} \cos a + S_{yz} \cos b \end{aligned}$$

in which $S, \cos a, \cos b, \cos c$ are four unknown quantities. The

three angles, however, are connected by the relation,

$$\cos^2 a + \cos^2 b + \cos^2 c = 1$$

and hence four equations exist between four unknowns.

Remembering the relation between the shearing stresses expressed in (174), the solution of the equations leads to a cubic equation for S , which is of the form,

$$S^3 - AS^2 + BS - C = 0 \quad (177)$$

in which the values of the three coefficients are,

$$A = S_x + S_y + S_z,$$

$$B = S_x S_y + S_y S_z + S_x S_z - S_{xy}^2 - S_{yz}^2 - S_{zx}^2$$

$$C = S_x S_y S_z + 2S_x S_y S_{yz} S_{zx} - S_x S_{yz}^2 - S_y S_{zx}^2 - S_z S_{xy}^2$$

and the three roots of this cubic equation are the three normal stresses of tension or compression, which are called the three principal unit-stresses and represented by S_1, S_2, S_3 .

The directions of these principal unit-stresses S_1, S_2, S_3 , with respect to the rectangular axes OX, OY, OZ , are given by the values of $\cos a, \cos b, \cos c$, which are found to be,

$$\cos a = (m_1/m)^{\frac{1}{2}} \quad \cos b = (m_2/m)^{\frac{1}{2}} \quad \cos c = (m_3/m)^{\frac{1}{2}}$$

in which m_1, m_2, m_3, m , represent the following functions of the given and principal unit-stresses:

$$m_1 = (S_y - S)(S_z - S) - S_{yz}^2$$

$$m_2 = (S_z - S)(S_x - S) - S_{zx}^2$$

$$m_3 = (S_x - S)(S_y - S) - S_{xy}^2$$

$$m = m_1 + m_2 + m_3$$

and it will now be shown that each principal stress is perpendicular to the plane of the other two.

Let S_1, S_2, S_3 be the three roots of the cubic equation (177). Let a_1, b_1, c_1 be the angles which S_1 makes with the three coordinate axes OX, OY, OZ , and let a_2, b_2, c_2 be the angles which S_2 makes with the same axes. The angle between the directions of S_1 and S_2 is then given by,

$$\cos \phi = \cos a_1 \cos a_2 + \cos b_1 \cos b_2 + \cos c_1 \cos c_2$$

Now in the first set of formulas of this article let S be made S_1 and a, b, c be changed to a_1, b_1, c_1 ; let the first equation be multiplied by $\cos a_2$, the second by $\cos b_2$, and the third by $\cos c_2$; and let the three equations be added; then,

$$S_1(\cos a_1 \cos a_2 + \cos b_1 \cos b_2 + \cos c_1 \cos c_2)$$

is one term in this sum. Again, let S be made S_2 , an a, b, c , be changed to a_2, b_2, c_2 ; let the equations be multiplied by $\cos a_1, \cos b_1, \cos c_1$, respectively, and added; then,

$$S_2(\cos a_1 \cos a_2 + \cos b_1 \cos b_2 + \cos c_1 \cos c_2)$$

is one term in the sum, while all the other terms are the same as before. Hence if S_1 and S_2 are unequal, the factor in the parenthesis, which is $\cos \phi$, must vanish; ϕ is therefore a right angle or S_1 and S_2 are perpendicular. In the same manner it may be shown that S_3 is perpendicular to both S_1 and S_2 .

The three principal stresses are hence perpendicular to each other, and as the only diameters of the ellipsoid which have this property are its axes, it follows that the directions of the principal stresses S_1, S_2, S_3 are those of the axes of the ellipsoid of stress. These principal stresses thus give the apparent maximum normal stresses of tension or compression; from (139) the corresponding true unit-stresses T_1, T_2, T_3 are then found.

An interesting property of the three rectangular stresses S_x, S_y, S_z , is that their sum is constant, whatever may be the position of the coordinate axes. For, the sum of the three principal stresses S_1, S_2, S_3 is equal to the coefficient A in the cubic equation of (177), and hence,

$$S_x + S_y + S_z = S_1 + S_2 + S_3$$

that is, the sum of the normal unit-stresses in any three rectangular directions is constant.

Prob. 177. When two principal stresses are equal, show that the value of each is $(AB - 9C)/(2A^2 - 6B)$, where A, B, C are the coefficients in (177).

ART. 178. MAXIMUM SHEARING STRESSES

As there are certain planes upon which the tensile and compressive unit-stresses are a maximum, so there are certain other planes upon which the shearing unit-stresses have their maximum values. In order to determine these it is well to take the axes of the ellipsoid as the coordinate axes, and upon the planes normal to these there are no shearing stresses. The stresses

S_1, S_2, S_3 will give apparent shearing stresses on other planes, while T_1, T_2, T_3 will give the true shearing stresses.

Let 1 2 3 in Fig. 178 be any plane whose normal makes the angles a, b, c with the coordinate axes. Let R be the resultant unit-stress upon this plane, and α, β, γ be the angles which it makes with the same axes. The angle between R and the normal to the plane is expressed by,

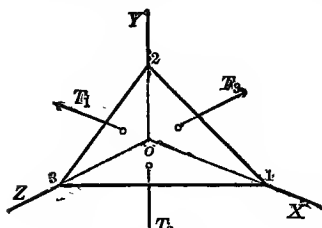

Fig. 178

$$\cos\theta = \cos a \cos \alpha + \cos b \cos \beta + \cos c \cos \gamma$$

and the resultant shearing unit-stress on the plane is,

$$R \sin\theta = R(1 - \cos^2\theta)^{\frac{1}{2}}$$

If R be apparent stress, this is the apparent shearing stress; if R be true stress, this is the true shearing stress which acts along the plane.

The value of R , as a true stress, is given by,

$$R^2 = (T_1 \cos a)^2 + (T_2 \cos b)^2 + (T_3 \cos c)^2$$

Now, since both $R \cos \alpha$, and $T_1 \cos a$ are components of R in the direction OX , they are equal, and hence,

$$\cos \alpha = (T_1/R) \cos a \quad \cos \beta = (T_2/R) \cos b \quad \cos \gamma = (T_3/R) \cos c$$

Substituting these in the value of $\cos \theta$, the resulting true shearing unit-stress is expressed by,

$$T^2 = (T_1 \cos a)^2 + (T_2 \cos b)^2 + (T_3 \cos c)^2 - (T_1 \cos^2 a + T_2 \cos^2 b + T_3 \cos^2 c)^2$$

by the discussion of which the values of a, b, c , which render T a maximum, are deduced. Bearing in mind that the sum of the squares of the three cosines is unity, the discussion gives,

$$\begin{array}{lll} c = 90^\circ & a = b = \pm 45^\circ & T = \pm \frac{1}{2}(T_1 - T_2) \\ a = 90^\circ & b = c = \pm 45^\circ & T = \pm \frac{1}{2}(T_2 - T_3) \\ b = 90^\circ & c = a = \pm 45^\circ & T = \pm \frac{1}{2}(T_3 - T_1) \end{array} \quad (178)$$

and therefore there are six planes of maximum shearing stress, each of which is parallel to one of the principal stresses and bisects the angle between the other two. On each of these planes

the shearing unit-stress is one half the difference of the principal unit-stresses whose directions are bisected.

The same investigation applies equally well to the apparent shearing unit-stresses, whose maximum values are,

$$S = \pm \frac{1}{2}(S_1 - S_2) \quad S = \pm \frac{1}{2}(S_2 - S_3) \quad S = \pm \frac{1}{2}(S_3 - S_1) \quad (178)'$$

and whose directions are the same as those of the maximum true shearing unit-stresses. The sign \pm indicates that the shears have opposite directions on opposite sides of the plane, but in numerical work it is always convenient to take them as positive or, rather, as signless quantities.

As an example, let a bar be subject to a tension of 3 000 pounds per square inch in the direction of its length and to a compression of 6 000 pounds per square inch upon two opposite sides. Here $S_1 = +3\,000$, $S_2 = -6\,000$, $S_3 = 0$; then the maximum apparent shearing stresses are 4 500, 3 000, and 1 500 pounds per square inch. But from (139), taking λ as $\frac{1}{3}$, the true tensile and compressive stresses as $T_1 = +5\,000$, $T_2 = -7\,000$, $T_3 = +1\,000$ pounds per square inch, and then from (178) the maximum true shearing stresses are 6 000, 4 000, and 2 000 pounds per square inch.

Prob. 178. Compute the maximum apparent and true shearing unit-stresses for a cast-iron parallelepiped, $2 \times 4 \times 8$ inches, which is subject to compression of 3 200 pounds upon its largest faces, 60 pounds upon its smallest faces, and 500 pounds upon the other faces.

ART. 179. DISCUSSION OF A CRANK PIN

To apply the preceding principles to a particular case, a crank pin similar to that investigated in Art. 98 may be taken. The axis OX is assumed parallel to the axis of the pin, OY parallel to the crank arm, and OZ perpendicular to both, the notation being the same as in Fig. 174. On one side of the crank pin near its junction with the arm there were found the following apparent stresses: A cross-shear from the pressure of the connecting rod giving $S_{xz} = 300$ pounds per square inch, a shear due to the transmitted torsion giving $S_{xy} = 900$ pounds per square

inch, a flexural stress due to the connecting-rod giving $S_x = +800$ pounds per square inch, a flexural stress due to the transmitted torsion giving $S_x = +1600$ pounds per square inch, and two compressions due to shrinkage giving $S_y = -4000$ and $S_z = -2000$ pounds per square inch.

The two shears having the same direction add together, as also the two tensions, and the data then are,

$$S_{xz} = 1200 \quad S_x = +2400 \quad S_y = -4000 \quad S_z = -2000$$

Inserting these in the cubic equation (177) it becomes,

$$S^3 + 3600S^2 - 7840000S - 2720000000 = 0$$

and its three roots are the three principal stresses. To solve this equation, put $S = x - 1200$, and it reduces to,

$$x^3 - 12160000x - 1109600000 = 0$$

As this cubic equation has three real roots, it is to be solved by the help of a table of cosines; thus let,

$$3r^2 = 12160000 \quad 2r^3 \cos 3\phi = 1109600000$$

from which $r = 2013$ and $\cos 3\phi = 0.6801$. Then from Table 17 is found $3\phi = 47^\circ 09'$, whence $\phi = 15^\circ 43'$. The roots are now computed as below, and by subtracting 1200 from each the three principal stresses are ascertained:

$$\begin{array}{lll} x_1 = 2r \cos \phi & = +3880 & S_1 = +2680 \\ x_2 = 2r \cos(\phi + 120^\circ) & = -2890 & S_2 = -4090 \\ x_3 = 2r \cos(\phi + 240^\circ) & = -990 & S_3 = -2190 \end{array}$$

and these are the apparent principal stresses in pounds per square inch. Taking $\epsilon = \frac{1}{3}$ for steel, the true principal stresses are now found by (139) to be,

$$T_1 = +4770 \quad T_2 = -4250 \quad T_3 = -1720$$

which show that the maximum true tensile stress is nearly double the apparent, while the maximum true compressive stress is 6 percent greater than the apparent.

An ordinary solution of this problem, in which no combination of stresses was made, would show the greatest tension to be 2400 pounds per square inch, while the complete solution as above given shows that the greatest true tension is nearly twice as great. The ordinary solution shows the shearing stress to

be 1 200 pounds per square inch, but by applying (178) to the above values of T it is seen that the maximum true shearing stress is 4 510 pounds per square inch. It thus appears that where many stresses combine, as at the junction of a crank pin with its web, the common methods of investigation give unit-stresses which are far too small; it also follows that designs for such cases, made by using the common methods, should be based upon low unit-stresses.

Prob. 179. Apply the cubic equation (177) to the case of a bar acted upon only by the tensile unit-stress S_x and the transverse shearing unit-stress S_{xy} . Deduce the principal stresses for this case.

ART. 180. THE ELLIPSE OF STRESS

The ellipse of stress is that particular case where one of the principal stresses is zero, in which event the last term of (177) vanishes. An instance of this is where $S_z=0$, $S_{yz}=0$, $S_{xz}=0$, which is that of a body subject to the normal unit-stresses S_x , S_y , and to the shearing unit-stress S_{xy} . The cubic equation then reduces to the simple quadratic,

$$S^2 - (S_x + S_y)S + S_x S_y - S_{xy}^2 = 0$$

and the two roots of this are the two principal apparent stresses whose directions correspond to the two axes of the ellipse. From this quadratic equation, the formulas (144) were derived.

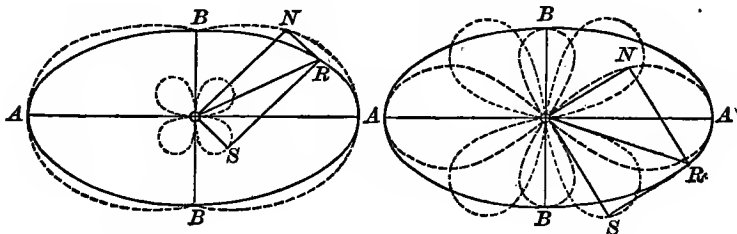

Fig. 180

Let S_1 and S_2 be these roots, and in Fig. 180 let OA and OB be laid off at right angles to represent their values. Let an ellipse be described upon the axes AA and BB , and let ϕ be the angle AON which any line ON makes with OA . Upon a

plane normal to ON at O the normal unit-stress of tension or compression has the value,

$$ON = S_1 \cos^2 \phi + S_2 \sin^2 \phi$$

and the tangential shearing unit-stress is,

$$OS = (S_1 - S_2) \sin \phi \cos \phi$$

while the resultant of these gives the resultant unit-stress,

$$OR = (S_1^2 \cos^2 \phi + S_2^2 \sin^2 \phi)^{\frac{1}{2}}$$

The diagrams in Figs. 180 give graphic representations of these values as the angle ϕ varies from 0 to 360 degrees. In the first diagram S_1 and S_2 are both tension or both compression, in the second diagram one is tension and the other compression. The broken curve shows the locus of the point N , and the dotted curve the locus of S . For every value of ϕ the lines OS and ON are at right angles to each other, and OR is their resultant.

As a simple example, take the case of a bolt subject to an axial tension of 2 000 and also to a cross-shear of 3 000 pounds per square inch. Here $S_x = +2\,000$, $S_{xy} = 3\,000$, and $S_y = 0$; the above quadratic equation then gives $S_1 = +4\,160$ and $S_2 = -2\,160$ pounds per square inch for the two maximum unit-stresses of tension and compression. The direction made by S_1 with the axis of the bolt, as found by the value of $\cos \alpha$ in Art. 175, is about $54\frac{1}{4}$ degrees. From (178)' the maximum shear is 3 160 pounds per square inch. These are the apparent maximum unit-stresses.

To find the true maximum stresses, formulas (139) give, taking $\frac{1}{3}$ as the factor of lateral contraction, $T_1 = +4\,880$, $T_2 = -3\,550$, $T_3 = -670$ pounds per square inch as the principal tensions and compressions; then from (178) the greatest shearing stress is $T = 4\,220$ pounds per square inch. Here the true maximum tension is 17 percent greater than the apparent, the true compression is 64 percent greater, and the true shearing stress is 33 percent greater. The true stresses cannot be represented by an ellipse, but an ellipsoid of internal stress results of which the second diagram in Fig. 180 may be regarded as a typical section.

Cases can, however, be imagined in which one of the true principal stresses is zero. If S_1, S_2, S_3 are the apparent stresses in three rectangular directions, it is seen from (139) that when $S_3 - \epsilon S_1 - \epsilon S_2$ is zero, the true stress T_3 is also zero. For instance, let a cube be under compression by three normal stresses of 30, 24, and 18 pounds per square inch and let $\epsilon = \frac{1}{3}$; then $T_1 = 16$, $T_2 = 8$, and $T_3 = 0$. Here the ellipse of true stress has its correct application and there are no true stresses in a plane normal to the plane of T_1 and T_2 .

Prob. 180. A body is subject to a tension of 4000 and to a compression of 6000 pounds per square inch, these acting at right angles to each other. Construct the ellipse of apparent stresses and find the positions of two planes on which there are no tensile or compressive stresses.

ART. 181. SHEARING MODULUS OF ELASTICITY

The shearing modulus of elasticity F , defined in Art. 15, must have a relation to the modulus E for tension or compression, since the action of shear upon a body produces internal tensile and compressive stresses (Art. 143). Let Fig. 181 represent the face of a cube which is acted upon by a vertical shear S , the edge of the cube being unity so that the vertical shearing unit-stress is also S . Under the action of this shear, the face of the cube becomes distorted, as shown greatly exaggerated by the broken lines, and the longer diagonal of the rhombus is under a tensile unit-stress while the shorter one is under a compressive unit-stress, each of these being equal to S , as proved in Art. 143. Let ϵ be the distortion parallel to the shear S ; then $\epsilon = S/F$ from the definition of shearing modulus of elasticity.

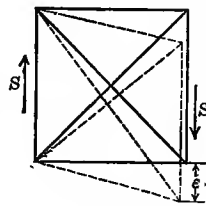

Fig. 181

The longer diagonal of the square has the length $2^{\frac{1}{2}}$ and after the distortion its length becomes $[1 + (1 + \epsilon)^2]^{\frac{1}{2}}$; by using the approximate method for extracting roots explained in Art. 13, and neglecting the square of ϵ , this reduces to $2^{\frac{1}{2}}(1 + \frac{1}{2}\epsilon)$. The

change in length of this diagonal hence is $2\frac{1}{2} \cdot \frac{1}{2}\epsilon$, and the unit-elongation is $\frac{1}{2}\epsilon$. In a similar manner the length of the shorter diagonal after the distortion is $2\frac{1}{2}(1 - \frac{1}{2}\epsilon)$ and the unit-shortening is $\frac{1}{2}\epsilon$. Accordingly the change per unit of length for each diagonal is $\frac{1}{2}S/F$.

Now let λ be the factor of lateral contraction (Art. 13) the mean value of which is $\frac{1}{4}$ for cast iron and $\frac{1}{3}$ for wrought iron and steel. When a body is acted upon by a tension producing the unit-stress S , there results a unit-elongation S/E and a lateral unit-shortening $\lambda S/E$. When a body is acted upon a tension producing the unit-stress S and by a compression at right angles producing the same unit-stress S , the unit-elongation is $(1 + \lambda)S/E$, as is shown in Art. 139; the lateral unit-shortening has also the same value. Accordingly, for the case of Fig. 181, each diagonal has suffered a change per unit of length equal to $(1 + \lambda)S/E$.

The change per unit of length for each of the diagonals of the face of the cube has now been found by two different methods; equating the two values, there results,

$$E = 2(1 + \lambda)F \quad \text{or} \quad F = E/2(1 + \lambda) \quad (181)$$

which give the relation between the two moduluses. Hence when E and λ have been determined by measurements on a bar under tension, the shearing modulus of elasticity may be computed.

Using the mean values of E given in Art. 9, and the mean values of λ as above stated, the mean values of the shearing modulus of elasticity are found to be as follows for iron and steel:

for cast iron,	$F = 6\,000\,000$ pounds per square inch
for wrought iron,	$F = 9\,400\,000$ pounds per square inch
for steel,	$F = 11\,200\,000$ pounds per square inch

and these have been verified by experiments on the torsion of shafts. There is little known regarding the values of λ for other materials, and it may be said that formula (181) does not apply to fibrous or non-homogeneous materials for the reason that E is not the same in different directions. It is not to be expected then that F could be correctly computed for timber from a value of E obtained from a tension parallel to the grain.

Four different methods are available for determining the shearing modulus of elasticity; first, by the measurement of the detrusion per unit of length in a short bar or beam like Fig. 181; second, from the angle of twist of a shaft (Art. 93); third, from the deflections of beams of different lengths and sizes (Art. 125); and fourth, by the use of formula (181). When sources of error are eliminated from the experiments, these different methods give results for F which agree very well for homogeneous materials. A fifth method, which is really an extension of the fourth, will be explained in the next article. All these methods, of course, apply only when the shearing elastic limit of the material is not exceeded by the unit-stress.

Prob. 181. A bar of steel, 0.5050 inches in diameter and 2.0000 long, is observed to be 2.0013 inches long when under a tension of 4 000 pounds, while its diameter is then found to be 0.5047 inches. Compute the shearing modulus of elasticity.

ART. 182. THE VOLUMETRIC MODULUS

The modulus of elasticity E for axial tension or compression is defined to be the ratio of the longitudinal unit-stress S to the unit-elongation or unit-shortening ϵ ; thus $E=S/\epsilon$. Similarly, the volumetric modulus of elasticity, which will be represented by G , is the ratio of a unit-stress S which acts in all directions upon the body to the change per unit of volume. Thus, if a uniform unit-pressure acts upon a body of volume unity and produces the change ϵ' in that volume, then $G=S/\epsilon'$. It is required to find the values of ϵ' and G , and also the relation between G and E .

Let λ be the factor of lateral contraction of the homogeneous cube, each edge of which is unity, while each face is subject to the same pressure S . Then, from Art. 139, the unit-shortening of each edge of the cube is $\epsilon'=(S-2\lambda S)/E$; or since ϵ represents S/E , the unit-shortening is $\epsilon'=(1-2\lambda)\epsilon$. The volume of the cube, which was originally unity, now becomes $(1-\epsilon')^3$, and hence the change in volume is $3\epsilon'$ when ϵ' is so small that its square and cube may be neglected. The change per unit of volume is then three times the change per unit of length of each edge of

the cube; hence $\varepsilon' = 3(1 - 2\lambda)\varepsilon$ gives the change per unit of volume, and hence the volumetric modulus G is $S/3(1 - 2\lambda)\varepsilon$, in which ε is the change per linear unit due to an axial unit-stress S of tension or compression only; accordingly,

$$G = S/\varepsilon' \quad G = S/3(1 - 2\lambda)\varepsilon \quad G = E/3(1 - 2\lambda) \quad (182)$$

are formulas for G , of which the third gives the relation between G and E . For example, λ is about $\frac{1}{3}$ for steel, and hence the volumetric modulus for steel is equal to the modulus for tension or compression.

In the last article the relation between the shearing modulus F and the tensile or compressive modulus E was deduced. The last formula of (181) and the last formula of (182) furnish two equations from which, by the elimination of λ , there is found $3EG + EF = 9FG$ as the relation between E , F , G ; hence,

$$E = 9FG/(F + 3G) \quad F = 3EG/(9G - E) \quad G = EF/(9F - 3E)$$

give the value of each modulus in terms of the other two. For example, let it be known that for cast iron $E = 15,000,000$ and $F = 6,000,000$ pounds per square inch; then $G = 10,000,000$ pounds per square inch. The last formula shows that F cannot be as small as $\frac{1}{3}E$, for G becomes infinite when E is equal to $3F$.

Water is matter which propagates stress in all directions so that a unit-pressure S applied to the surface of a column of water produces a resisting unit-pressure S on all the confining surfaces. According to the experiments made by Grassi in 1850, the decrease in a unit-volume of water caused by the pressure of one atmosphere, or 14.7 pounds per square inch, has a mean value of 0.00005; hence the mean volumetric modulus of elasticity for water is $G = 14.7/0.00005 = 294,000$ pounds per square inch, which is about one one-hundredth of that of steel, so that water is about 100 times more compressible than is steel within its elastic limit. Water has no proper value of E , because it is impossible for a column to be subjected to longitudinal pressure only; when water in a pipe is under axial pressure, the shortening that is measured is due to a unit-pressure acting laterally as well as axially, and this gives the decrease in volume if the walls of the pipe are unyielding.

Prob. 182. Prove, for a homogeneous solid, that the ratio G/F is equal to $2(\tau + \lambda)/3(\tau - 2\lambda)$. Also that the value of λ may be expressed by $\frac{1}{2} - E/6G$.

ART. 183. STORED INTERNAL ENERGY

The cases of resilience, or stored internal energy, which were discussed in Chapter XIII, relate only to simple axial stress and to simple shear; when a body is subject to several external forces acting in different directions, the expressions for resilience become more complex. Fig. 183 represents a parallelepiped, the faces of which are acted upon only by the normal unit-stresses S_1, S_2, S_3 .

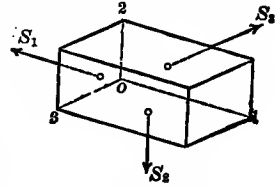

Fig. 183

Let this parallelepiped be homogeneous so that the modulus of elasticity E and the factor of lateral contraction λ are the same in all directions. Let l_1 be the length parallel to S_1 , and a_1 the section area normal to S_1 ; then the total stress on this section area is $a_1 S_1$, and from (10) and (139) the change in the length of l_1 is $l_1(S_1 - \lambda S_2 - \lambda S_3)/E$. The work done while the stress $a_1 S_1$ is increasing from zero up to its final value is one-half the product of the stress and change of length, provided the elastic limit of the material is not exceeded (Art. 119); hence the stored internal energy due to S_1 is $\frac{1}{2} a_1 l_1 (S_1^2 - \lambda S_1 S_2 - \lambda S_1 S_3)/E$ and this is proportional to the volume $a_1 l_1$. A similar expression may be written for the energy due to S_2 and another for that due to S_3 ; and the sum of the three is,

$$K = \frac{1}{2} V (S_1^2 + S_2^2 + S_3^2 - 2\lambda S_1 S_2 - 2\lambda S_1 S_3 - 2\lambda S_2 S_3) / E \quad (183)$$

in which V denotes the volume of the parallelepiped. Here the sign of each S is positive for tension and negative for compression.

A discussion of this formula shows that K has usually a smaller value when the signs of S_1, S_2, S_3 are the same than when one has a sign opposite to that of the other two. When the unit-stresses are equal in sign and magnitude, then $K = \frac{3}{2}(\tau - 2\lambda) V \cdot S^2 / E$; for steel λ is $\frac{1}{3}$ and the resilience becomes $K = \frac{1}{2}(S^2/E) V$, which is the same as for simple axial stress (Art. 120). As a numerical

example, let the three edges of the parallelopiped o_1, o_2, o_3 be 8, 6, and 4 inches long and the material be cast iron for which λ is $\frac{1}{4}$, and let the unit-stresses S_1, S_2, S_3 be 3 000, 4 000, 5 000 pounds per square inch compression; then $K=170$ inch-pounds = 14 foot-pounds is the stored internal energy.

When the above parallelopiped is subject to the action of six pairs of shears of which the unit-stresses are S_{12}, S_{23}, S_{31} , in the notation of Art. 174, the corresponding unit-detursions are $\frac{1}{2}S_{12}^2/F, \frac{1}{2}S_{23}^2/F, \frac{1}{2}S_{31}^2/F$, where F is the shearing modulus of elasticity, and the sum of these multiplied by the volume of the body gives,

$$K' = \frac{1}{2}V(S_{12}^2 + S_{23}^2 + S_{31}^2)/F \quad (183)'$$

as the stored energy due to the shears. This is to be added to the value of K in (183) when normal stresses also act upon the faces of the parallelopiped. A comparison of the two formulas shows that, if a body is acted upon by normal and tangential forces of equal intensity in three rectangular directions, the stored internal energy due to shearing may often be greater than that due to the normal stresses.

The principle of least work, established in Art. 126, states that the internal stresses which prevail in a body under the action of external forces are those which render the stored internal energy a minimum. This principle may be used in connection with (183) to determine the stresses S_1, S_2, S_3 in cases where the conditions of static equilibrium are insufficient in number. For example, it was assumed in Art. 163 that the tangential and radial stresses in a spherical annulus were connected by the relation $2S+R=a$ constant. This assumption may seem an arbitrary one, but it can be shown by an algebraic investigation, which is too lengthy to be given here, that the total stored internal energy is less when $2S+R$ is constant throughout the spherical annulus than when this sum varies according to any function of the distance x from the center.

The ether of space transmits light, electricity, and gravitation from one body to another. The phenomena of gravitation are familiar to every one, but the explanation of its cause has not yet

been discovered. All observations and theory indicate that the ether is an elastic substance which obeys the laws of the mathematical theory of elasticity. Accordingly it seems that the general conclusions of Art. 163 regarding the distribution of stresses in hollow spheres should apply to those stresses in the ether which cause the mutual gravitation of bodies of matter; if this be so, these stresses vary inversely as the cube of the distance. The actual forces of gravitation, however, vary inversely as the square of the distance, and it is not easy to see how this law is deduced from that of the distribution of the stresses. To solve the great riddle of gravitation, a more definite knowledge is required regarding the constitution of matter, and the indications are that an explanation may be obtained during the twentieth century.

Prob. 183. Consult Isenkrahe's *Das Räthsel von der Schwerkraft* (Braunschweig, 1879) for critical reviews of the various attempts to explain the phenomena of gravitation.

APPENDIX AND TABLES

ART. 184. VELOCITY OF STRESS

WHEN an external force is suddenly applied to a body, the stresses produced are not instantaneously generated, but are propagated by a wave-like motion through the mass. Hence there is a velocity of transmission of stress which will be shown to depend upon the stiffness and density of the material. In fact, a sudden stress is propagated through a body in the same manner as sound is propagated through air or water. Let v be this velocity, w the weight of the material per cubic unit at a place where the acceleration of gravity is g , and E the modulus of elasticity of the material. It is required to find v in terms of w , g , and E .

If F is a force which acting continuously for one second upon a body of the weight W produces the velocity u , and if the same body when falling vertically acquires under the action of gravity the velocity g in one second, then the constant forces are proportional to the accelerations that they produce; hence,

$$F/W = u/g \quad \text{or} \quad Fg = Wu$$

which is one of the well-known laws of mechanics.

Now let a unit-stress S be applied to the end of a bar of section-area unity, producing the unit-elongation ε upon the first element of its length. The elongation of the first element transmits the stress to the second element, and this in turn produces an elongation of the second element, and so on. At the end of one second of time the length v is stressed, and the total elongation in that length will be εv . Thus in one second the center of gravity of the bar is moved the distance $\frac{1}{2}\varepsilon v$, and its velocity u at the end of the second is εv . Now referring to the formula $Fg = Wu$, the value of F is S which is equal to εE , the value of W is wv , and hence,

$$\varepsilon E \cdot g = wv \cdot \varepsilon v \quad \text{or} \quad v = (Eg/w)^{\frac{1}{2}}$$

which is the formula for the velocity of wave propagation in elastic materials first deduced by Newton.

Taking for g the mean value 32.16 feet per second per second, for w the values in Table 1, for E the values in Table 2, and reducing E to pounds per square foot, since g and w are in terms of feet, the mean values of the velocity of transmission of stress in different materials are found to be,

for Timber,	$v=13$ 200 feet per second
for Stone,	$v=13$ 200 feet per second
for Cast Iron,	$v=12$ 400 feet per second
for Wrought Iron,	$v=15$ 500 feet per second
for Steel,	$v=17$ 200 feet per second

For water confined in a pipe, the value of E is the same as the volumetric modulus G (Art. 182), and taking w as $62\frac{1}{2}$ pounds per cubic foot, the velocity v is about 4 670 feet per second, which agrees well with experiments on the velocity of sound in water.

In the mathematical theory of elasticity, the velocity of transmission of stress must be taken into account in order to obtain complete solutions of the problems of impact and suddenly applied forces. The above formula also gives the velocity of sound, light, and all wave propagations in elastic media. The ratio w/g is a constant for the same material at any point in space, and it expresses the density, while E is an index of the stiffness. At the surface of the earth the quantity E/w for steel is about 8 820 000, but for the ether it must be about 30 100 000 000 000 000 in order to account for the fact that the velocity of light is 984 000 000 feet per second. The stiffness of the ether is hence very great compared to its density; if its density be one one-thousandth of that of hydrogen, its stiffness is 37 times as great as that of steel. The opinion has long prevailed that the force of gravitation is instantaneously propagated through the ether, but the indications now are that its velocity is the same as that of light and electricity.

Prob. 184. Verify the statements in the last paragraph. Consult Van Nostrand's Science Series, No. 85, and ascertain the values deduced by Wood for the density and stiffness of the ether of space.

ART. 185. ELASTIC-ELECTRIC ANALOGIES

In Art. 193 of Treatise on Hydraulics there are pointed out some of the analogies between hydraulic and electric phenomena. The theory of elasticity furnishes other analogies which are interesting and one of these is perhaps more perfect, from a formal point of view, than any that is furnished by hydraulics. Let a bar of length l and section area a be under the axial tension P , let E be the modulus of elasticity of the material and e the change of length due to the tension; then from Art. 10, this elongation is $e = (l/aE)P$. Let the reciprocal of E be called E' , then $e = E'(l/a)P$. This equation is the same as that given by Ohm's law for the loss in voltage when a current flows through a wire, if e represents the lost voltage and P the current; the quantity $E'(l/a)$ is called electric resistance and it varies directly as the length of the wire, inversely as its section area, and directly as the specific electric resistance E' . The formal analogy is perfect, but the fundamental ideas are quite different in the two cases. In the bar e is the loss in length which varies directly as l , inversely as a , and directly as the reciprocal of E , but the phenomenon is a static one entirely, for no energy is lost or transmitted through the bar.

Referring now to Fig. 110a, let l_1, l_2, l_3 be the lengths of the three columns under the compression P , and a_1, a_2, a_3 their section areas, while E_1, E_2, E_3 are their moduluses of elasticity. Let the quantities $l_1/a_1E_1, l_2/a_2E_2, l_3/a_3E_3$ be called resistances and be designated by the letters r_1, r_2, r_3 . Then by formula (110) the total change of length of the compound column is given by $e = (r_1 + r_2 + r_3)P$. This may be called an arrangement 'in series,' and as in electric flow, the total resistance is the sum of the separate resistances.

Fig. 110b represents a column which may be said to be an arrangement 'in parallel,' and here the three lengths are equal to l , while the section areas are a_1, a_2, a_3 . Formula (110)'' gives the change of length for this case as $e = P/(1/r_1 + 1/r_2 + 1/r_3)$, which agrees with the electric law governing the loss of voltage

in a branched circuit, the total resistance being the reciprocal of the sum of the reciprocals of the separate resistances. The loads P_1 , P_2 , P_3 on the three parts of the column correspond to the currents in the three parts of the divided wire, while the change of length e corresponds to the drop in voltage which is the same for each of the three parts. The load P divides between the three parts inversely as their resistances to change of length, while the electric current divides between three branches inversely as their electric resistances.

With respect to work the analogy is less perfect. Resuming the equation $e = (l/aE)P$ for the change in length of a bar under axial stress, the product of P and e is work, while this product is work per unit of time if e represents voltage and P represents current. This is because P represents force for the bar, while for the electric wire it represents electric charge per unit of time. For the bar the external work is spent in storing internal energy in the bar; for the wire the work Pe is lost in heat. The above analogy is hence merely a formal one and the fundamental ideas are quite different in the two cases.

The phenomena of torsion afford another analogy and here energy may be transmitted through a rotating shaft, but no energy is lost if the material is not stressed beyond the shearing elastic limit. Here the angle of twist for a round shaft varies directly as the length of the shaft and also directly as the transmitted power, but it varies inversely as the square of the section area. Some theories of electricity and magnetism appear to indicate that forces of shearing and torsion in the ether may in large part account for the observed phenomena. Reiff's *Elasticität und Elektrizität* (Leipzig, 1893) contains a theory of electricity developed from the fundamental equations of the mathematical theory of elasticity.

ART. 186. MISCELLANEOUS PROBLEMS

Below are given a number of topics which have not been treated in the preceding pages, as their discussion properly belongs to special works on special branches of applied mechanics.

Teachers who wish to give prize problems to their classes may perhaps find some of these useful for that purpose.

Prob. 186*a*. Discuss a screw with square threads at the end of a bolt, and find its length in order that its shearing strength may be equal to the tensile strength of the bolt.

Prob. 186*b*. Let a helical spring consist of round wire, let r be the radius of the coil, d the diameter of the wire, and P the tensile and compressive load upon the spring. Show that the shearing unit-stress in the wire is $16Pr/\pi d^3$.

Prob. 186*c*. The data being the same as in the last problem show that the elongation or shortening of the spring under the load P is $64nPr^3/Fd^4$, where n is the number of coils and F is the shearing modulus of elasticity.

Prob. 186*d*. A load P is supported by three strings of equal size hung in the same vertical plane from the ceiling of a room. The middle string is vertical and each of the others makes an angle θ with it. If P_1 is the stress on the middle string and P_2 the stress on each of the others, show that,

$$P_1 = P/(1 + 2 \cos^3 \theta) \quad P_2 = P \cos^2 \theta / (1 + 2 \cos^3 \theta)$$

To solve this problem the condition must be introduced that the internal work of all the stresses is a minimum.

Prob. 186*e*. A load P is supported by three strings of equal size lying in the same plane. The middle string is vertical, one string makes with it the angle θ on one side, and the second string makes with it the angle ϕ on the other side. Find the stresses in the strings.

Prob. 186*f*. A circular ring of mean diameter d is pulled in the direction of a diameter by two tensile forces each equal to P . Show that the maximum bending moment is at the section where P is applied, and that its value is $\frac{1}{2}Pd^3/\pi(d^2 + 4r^2)$, where r is the radius of gyration of the cross-section of the ring.

Prob. 186*g*. An elliptical chain link has the mean length $4d_1$ and the mean width $2\frac{1}{2}d_1$, where d_1 is the diameter of the round section area. When an open chain link of these proportions is subject to the tension P in the direction of its length, the greatest bending moment occurs where the tension is applied, and the greatest unit-stress is $8.1P/d_1^2$. For a chain link with a cross stud, the greatest unit-stress is $3.9P/d^2$. These results are correct only when the elastic limit of the material is not exceeded.

ART. 187. ANSWERS TO PROBLEMS

The following are the answers to some of the problems given in the preceding pages, the number of the problem being in parenthesis. The instructions in Art. 8 should be carefully followed by the student, and in no event should he refer to an answer until the solution of the problem is completed. However satisfactory it may be for a student to be able to know that his solutions give the correct results, it is well for him to keep in mind that in actual engineering work the solutions of problems will never be given.

(1*b*) 4.16 inches. (2*b*) 3.33 inches. (3*a*) 55 400 pounds per square inch. (5*b*) 1 780 feet. (7*a*) 2.71 and 3.33 inches. (8*b*) 3.57 centimeters. (9*a*) 26 300 000 pounds per square inch. (14*b*) 122 foot-pounds. (15) 1' 09". (17) 26.2 square inches. (18*a*) 183.5 kilograms. (21) \$1058.84. (23) 3 140 pounds. (25*a*) 4.04 cents. (26*a*) 105 000 pounds. (29*a*) $P_1/P_2 = 3/2$. (30*a*) 0.88 inches. (31*a*) 2 500 pounds per square inch. (32) 28 000 pounds per square inch. (34*b*) $3\frac{1}{16}$ inches; 72 percent. (35*a*) $2\frac{1}{8}$ inches. (39) $X = 242$, $Y = 140$ pounds. (41) 985 pounds per square inch. (42*b*) $c = \frac{1}{3}d(2b + b')/(b + b')$. (45*a*) $8\frac{1}{2}$ miles. (49*b*) 6 000 pounds. (50*a*) 5; 2.5. (50*b*) 6 feet 5 inches. (51) 5 610 and $\frac{1}{3}$ 170 pounds per square inch. (52*a*) 0.018 inches. (54*a*) 14 500 000 pounds per square inch. (55*b*) 74 500 kilograms per square centimeter. (56*a*) 8 to 3; 64 to 9. (58*b*) 0.72 inches. (59*b*) $R_1 = 290$ pounds. (60*b*) $\kappa = 0.366$; $\kappa = 0.577$. (61*a*) $l/m = 2.828$. (62*a*) $\kappa l/(1 + 2\kappa)$ and $(2 - \kappa)l/(3 - 2\kappa)$. (63*b*) 0.027 inches. (66*c*) $0^\circ 25' 47''$. (71*a*) $-\frac{1}{8}wl$. (73) $R_1 = -113$ pounds. (74*a*) $0.0131 wl^3/EI$. (75*a*) $n = 0.6095$. (76*b*) $I_1 = 268.3$, $I_2 = 441.5$ inches⁴. (77*a*) $r = \frac{1}{2}(d_1^2 + d_2^2)^{\frac{1}{2}}$. (79*a*) 5.05 inches. (81*a*) $3\frac{1}{8}$. (82*a*) 23 000 pounds. (83) $13\frac{1}{2}$ and $16\frac{1}{2}$ inches. (89*a*) 30 pounds. (89*b*) 105 degrees. (90*b*) 691 pounds per square inch. (91*b*) 1.2 horse-powers. (92*a*) 8.1. (92*b*) 144 to 100. (93*b*) 9 380 000 pounds per square inch. (96*b*) $2\frac{1}{16}$ inches. (99*b*) 100 to 79. (101*a*) $4\frac{1}{4}$ inches. (101*b*) Nearly 8 inches. (105) $S_w = 9 420$ pounds per square inch and $\phi = 54^\circ 13'$. (107*a*) 4.9. (108) $S_s = 205$ pounds per square inch. (119*a*) 122 foot-pounds. (120*a*) $5\frac{1}{8}$ horse-power. (121*b*) 0.52 horse-powers. (123) $3Pl^3/256EI$. (126) $\frac{1}{2}P$. (130) 120 feet per second. (148) 2 886 000 pounds. (149) $S = +14 000$ pounds per square inch. (150) 18 000 pounds per square

inch. (151) 54 000 pounds per square inch. (155a) Deduce an expression for R_1 in terms of the given radii and S_e ; then find the value of r_2 which renders R_1 a maximum. (156) 6 rollers. (157) 64 and 7. (160a) $r - (r^2 - \frac{3}{4}d^2)^{\frac{1}{2}}$. (163a) 1.6 inches. (165) About 1.4 inches. (175) $56^\circ 19'$ with axis of bolt. (177) See theory of equations in algebra. (180) $54^\circ 44'$ with the greater apparent stress.

Evolvi varia problemata. In scientiis enim ediscendis prosunt exempla magis quam præcepta. Qua de causa in his fusius expatiatum sum.—NEWTON.

Nous avons pour but, non de donner un traité complet, mais de montrer, par des exemples simples et variés, l'utilité et l'importance de la théorie mathématique de l'élasticité.—LAMÉ.

Homo, naturæ minister et interpres, tantum facit et intelligit quantum de naturæ ordine re vel mente observaverit, nec amplius scit aut potest.—BACON.

ART. 188. EXPLANATION OF TABLES

Tables 1-5 give average physical constants for materials and Tables 6-13 give properties of beams and columns. At the foot of each table is a reference to the articles where its use is explained.

Table 14 gives weights per linear foot of wrought-iron bars both square and round, the side of the square or the diameter of the circle ranging from $\frac{1}{8}$ to $10\frac{3}{4}$ inches. Approximate weights of bars of other materials may be derived from this table by the following rules:

for Timber,	divide by 12
for Brick,	divide by 4
for Stone,	divide by 3
for Cast Iron,	subtract 6 percent
for Steel,	add 2 percent

For example, a cast-iron bar $6\frac{7}{8}$ inches square and 8 feet long weighs $8(157.6 - 0.06 \times 157.6) = 1185$ pounds. In like manner a steel bar $2\frac{3}{8}$ inches in diameter and 4 feet 9 inches in length weighs $4\frac{3}{4}(12.53 + 0.02 \times 12.53) = 60.7$ pounds.

Table 15 gives four-place squares of numbers from 1.00 to 9.99, the arrangement being the same as that of a logarithmic table. By properly moving the decimal points, four-place squares of other numbers may also be taken out. For example, the square of 0.874 is 0.7639, that of 87.4 is 7 639, and that of 874 is 763 900, all correct to four significant figures.

Table 16 gives four-place areas of circles for diameters ranging from 1.00 to 9.99, arranged in the same manner. By properly moving the decimal point, four-place areas for all circles may be found. For instance, if the diameter is 4.175 inches, the area is 13.69 square inches; if the diameter is 0.535 inches, the area is 0.2248 square inches; if the diameter is 12.2 feet, the area is 116.9 square feet, all correct to four significant figures.

Table 17 gives four-place trigonometric functions of angles, and Table 18 the logarithms of these functions. The term 'arc' means the length of a circular arc of radius unity, or the value of the angle in radians, while 'coarc' is the complement of the arc. If θ is the number of degrees in an angle, the value of the arc is $\pi\theta/180$, and this subtracted from $\frac{1}{2}\pi$ gives the coarc.

Table 19 gives four-place logarithms of numbers and these are sufficiently precise for nearly all computations arising in the application of the principles of mechanics of materials. The differences in the last column enable interpolations to be made so that four-place logarithms of numbers with four significant figures may be taken out; for example, the logarithm of 0.6534 is $\bar{1}.8152$.

Table 20, taken from the author's *Elements of Precise Surveying and Geodesy*, gives mathematical constants and their logarithms to nine decimals; this is a greater number of decimals than will ever be needed in computations on the materials of engineering, but they will sometimes be required for the discussion of geodetic and physical measurements.

TABLE 1. AVERAGE WEIGHT AND EXPANSIBILITY

Material	Weight per Unit Volume		Coefficient of Linear Expansion	
	Pounds per cubic foot	Kilograms per cubic meter	For 1° Fahrenheit	For 1° Centigrade
Brick	125	2 000	0.000 0050	0.000 0090
Concrete	150	2 400	0.000 0055	0.000 0099
Stone	160	2 560	0.000 0050	0.000 0090
Timber	40	600	0.000 0020	0.000 0036
Cast Iron	450	7 200	0.000 0062	0.000 0112
Wrought Iron	480	7 700	0.000 0067	0.000 0121
Structural Steel	490	7 800	0.000 0065	0.000 0117
Strong Steel	491	7 800	0.000 0065	0.000 0117

Explanation in Arts. 17 and 100

TABLE 2. AVERAGE ELASTIC PROPERTIES

Material	Elastic Limit		Modulus of Elasticity	
	Pounds per square inch	Kilograms per square centimeter	Pounds per square inch	Kilograms per square centimeter
Brick	1 000	70	2 000 000	140 000
Concrete	800	56	2 500 000	175 000
Stone	2 000	140	6 000 000	420 000
Timber	3 000	210	1 500 000	105 000
Cast Iron	6 000	420	15 000 000	1 050 000
	20 000	1 400	15 000 000	1 050 000
Wrought Iron	25 000	1 750	25 000 000	1 750 000
Structural Steel	35 000	2 450	30 000 000	2 100 000
Strong Steel	50 000	3 500	30 000 000	2 100 000

Explanation in Arts. 2 and 9. Values for Brick, Concrete, and Stone are for compression only. For Cast Iron the upper values apply to tension and the lower ones to compression. For other materials the values apply to both tension and compression.

TABLE 3. AVERAGE TENSILE AND COMPRESSIVE STRENGTH

Material	Ultimate Tensile Strength		Ultimate Compressive Strength	
	Pounds per square inch	Kilograms per square centimeter	Pounds per square inch	Kilograms per square centimeter
Brick			3 000	210
Concrete	300	21	3 000	210
Stone			6 000	420
Timber	10 000	700	8 000	560
Cast Iron	20 000	1 400	90 000	6 300
Wrought Iron	50 000	3 500	50 000	3 500
Structural Steel	60 000	4 200	60 000	4 200
Strong Steel	100 000	7 000	120 000	8 400

Explanation in Arts. 4, 5, 19-25

TABLE 4. AVERAGE SHEARING AND FLEXURAL STRENGTH

Material	Ultimate Shearing Strength		Ultimate Flexural Fiber Strength	
	Pounds per square inch	Kilograms per square centimeter	Pounds per square inch	Kilograms per square centimeter
Brick	700	50	800	55
Concrete	800	56		
Stone	1 500	105	2 000	140
Timber, with grain	500	35		
Timber, across grain	3 000	210	9 000	630
Cast Iron	20 000	1 400	35 000	2 400
Wrought Iron	40 000	2 800		
Structural Steel	50 000	3 500		
Strong Steel	75 000	5 200	110 000	7 700

Explanation in Arts. 6 19-25, 52

TABLE 5. WORKING UNIT-STRESSES FOR BUILDINGS

ABSTRACTED FROM THE BUILDING CODE OF THE CITY OF NEW YORK, N. Y.

Material	Pounds per Square Inch			
	Tension	Com- pression	Shear	Flexure
Hemlock	600	500	275*	600
Spruce	800	800	320*	800
White Pine	800	800	250*	800
Yellow Pine	1 200	1 000	500*	1 200
Oak	1 000	900	600*	1 000
Brick		300		50
Brickwork				
In Portland Cement Mortar		250		30
In Natural Cement Mortar		208		30
In Lime Mortar		111		
Concrete				
Portland Cement, 1, 2, 4		230		30
Natural Cement, 1, 2, 4		125		16
Rubble Stonework				
In Portland Cement Mortar		140		
In Natural Cement Mortar		111		
In Lime Mortar		70		
Sandstone		1 000		100
Limestone		1 500		150
Marble		900		120
Granite		1 700		180
Slate		1 000		400
Cast Iron	3 000	16 000	3 000	3 000 Ten. 16 000 Comp.
Wrought Iron	12 000	12 000	6 000	
Wrought-iron shop rivets			7 500	
Wrought-iron field rivets			6 000	
Rolled Steel	16 000	16 000	9 000	16 000
Steel shop rivets			10 000	
Steel field rivets			8 000	
Cast Steel	16 000	16 000		

Explanation in Art. 7. * Across grain.

TABLE 6. STEEL I-BEAM SECTIONS

Depth of Beam Inches	Weight per Foot Pounds	Width of Flange Inches	Section Area <i>a</i> Sq. In.	Axis perpendicular to web			Axis parallel to web	
				Moment Inertia <i>I</i> Inches ⁴	Section Factor <i>I/c</i> Inches ³	Radius Gyration <i>r</i> Inches	Moment Inertia <i>I</i> Inches ⁴	Radius Gyration <i>r</i> Inches
24	100	7.25	29.41	2380	198.4	9.00	48.56	1.28
*24	80	7.00	23.32	2088	174.0	9.46	42.86	1.36
20	100	7.28	29.41	1656	165.6	7.50	52.65	1.34
*20	80	7.00	23.73	1467	146.7	7.86	45.81	1.39
*20	65	6.25	19.08	1170	117.0	7.83	27.86	1.21
18	70	6.26	20.59	921.3	102.4	6.69	24.62	1.09
*18	55	6.00	15.93	795.6	88.4	7.07	21.19	1.15
15	100	6.77	29.41	900.5	120.1	5.53	50.98	1.31
*15	80	6.40	23.81	795.5	106.1	5.78	41.76	1.32
*15	60	6.00	17.67	609.0	81.2	5.87	25.96	1.21
*15	42	5.50	12.48	441.7	58.9	5.95	14.62	1.08
12	55	5.61	16.18	321.0	53.5	4.45	17.46	1.04
*12	40	5.25	11.84	268.9	44.8	4.77	13.81	1.08
*12	31½	5.00	9.26	215.8	36.0	4.83	9.50	1.01
10	40	5.10	11.76	158.7	31.7	3.67	9.50	0.90
*10	25	4.66	7.37	122.1	24.4	4.07	6.89	0.97
9	35	4.77	10.29	111.8	24.8	3.29	7.31	0.84
*9	21	4.33	6.31	84.9	18.9	3.67	5.16	0.90
8	25½	4.27	7.50	68.4	17.1	3.02	4.75	0.80
*8	18	4.00	5.33	56.9	14.2	3.27	3.78	0.84
7	20	3.87	5.88	42.2	12.1	2.68	3.24	0.74
*7	15	3.66	4.42	36.2	10.4	2.86	2.67	0.78
6	17½	3.57	5.07	26.2	8.7	2.27	2.36	0.68
*6	12½	3.33	3.61	21.8	7.3	2.46	1.85	0.72
5	14½	3.29	4.34	15.2	6.1	1.87	1.70	0.63
*5	9½	3.00	2.87	12.1	4.8	2.05	1.23	0.65
*4	10½	2.88	3.09	7.1	3.6	1.52	1.01	0.57
*4	7½	2.66	2.21	6.0	3.0	1.64	0.77	0.59
3	7½	2.52	2.21	2.9	1.9	1.15	0.66	0.52
*3	5½	2.33	1.63	2.5	1.7	1.23	0.46	0.53

Explanation in Arts. 44 and 51. * Standard sizes; others are special.

TABLE 7. STEEL BULB-BEAM SECTIONS

Depth Inches	Weight per Foot Pounds	Section Area Sq. In.	Axis perpendicular to web				Axis parallel to web	
			Moment Inertia I Inches ⁴	Base to Neutral Axis Inches	Section Factor I/c Inches ³	Radius Gyration r Inches	Moment Inertia I Inches ⁴	Radius Gyration r Inches
11½	32.2	9.51	179.3	5.07	27.9	4.34	6.36	0.82
10	28.0	8.20	118.5	4.28	20.7	3.80	6.08	0.86
9	25.0	7.35	85.0	3.90	16.7	3.40	4.85	0.81
8	21.0	6.17	57.8	3.48	12.8	3.06	3.58	0.76
7	18.0	5.32	37.0	3.04	9.3	2.64	2.56	0.69
6	14.5	4.27	21.8	2.61	6.4	2.26	1.62	0.62
5	11.5	3.39	12.0	2.22	4.3	1.88	1.01	0.55

Explanation in Art. 44

TABLE 8. STEEL T SECTIONS

Size Width by Depth Inches	Weight per Foot Pounds	Section Area a Sq. In.	Axis perpendicular to web				Axis parallel to web	
			Moment Inertia I Inches ⁴	Base to Neutral Axis Inches	Section Factor I/c Inches ³	Radius Gyration r Inches	Moment Inertia I Inches ⁴	Radius Gyration r Inches
6×4	17.4	5.12	6.56	1.00	2.19	1.13	9.33	1.35
5×4	15.3	4.54	6.16	1.08	2.11	1.17	5.41	1.09
4×4	10.9	3.10	4.70	1.15	1.64	1.23	2.20	0.85
4×3	9.0	2.67	1.99	0.78	0.90	0.87	2.10	0.89
3½×3½	7.0	2.08	2.27	0.94	0.89	1.04	1.03	0.94
3½×3	7.0	2.11	1.65	0.80	0.75	0.88	1.18	0.75
3×3	6.5	1.91	1.57	0.87	0.74	0.91	0.75	0.62
3×2½	5.0	1.46	0.78	0.66	0.42	0.73	0.60	0.64
2½×3	6.0	1.76	1.48	0.93	0.71	0.92	0.44	0.50
2½×2½	5.8	1.71	0.95	0.76	0.55	0.75	0.48	0.53
2×2	3.5	1.03	0.37	0.60	0.26	0.60	0.18	0.41
2×1½	3.0	0.91	0.16	0.45	0.15	0.42	0.17	0.44
2×1	2.5	0.72	0.05	0.27	0.07	0.26	0.17	0.49

Explanation in Art. 44

TABLE 9. STEEL CHANNEL SECTIONS

Depth	Weight per Foot	Width of Flange	Section Area <i>a</i>	Axis perpendicular to web		Axis parallel to web		
				Moment Inertia <i>I</i>	Radius Gyration <i>r</i>	Moment Inertia <i>I</i>	Radius Gyration <i>r</i>	Outside of Web to Center of Gravity
Inches	Pounds	Inches	Sq. In.	Inches ⁴	Inches	Inches ⁴	Inches	Inches
15	55	3.82	16.18	430.2	5.16	13.19	0.87	0.82
15	45	3.62	13.24	375.1	5.32	10.29	0.88	0.79
15	35	3.43	10.29	320.0	5.58	8.48	0.91	0.79
*15	33	3.40	9.90	312.6	5.62	8.23	0.91	0.79
12	40	3.42	11.76	197.0	4.09	6.63	0.75	0.72
12	30	3.17	8.82	161.7	2.28	5.21	0.77	0.68
12	25	3.05	7.35	144.0	4.43	4.53	0.78	0.68
*12	20½	2.94	6.03	128.1	4.61	3.91	0.80	0.68
10	35	3.18	10.29	115.5	3.35	4.66	0.67	0.70
10	25	2.89	7.35	91.0	3.52	3.40	0.68	0.62
10	20	2.74	5.88	78.7	3.66	2.85	0.70	0.61
*10	15	2.60	4.46	66.9	3.87	2.30	0.72	0.64
9	25	2.81	7.35	70.7	3.10	2.98	0.64	0.61
9	15	2.49	4.41	50.9	3.40	1.95	0.66	0.59
*9	13½	2.43	3.89	47.3	3.49	1.77	0.67	0.60
8	21½	2.62	6.25	47.8	2.77	2.25	0.60	0.58
8	16½	2.44	4.78	39.9	2.89	1.78	0.61	0.56
*8	11½	2.26	3.35	32.3	3.11	1.33	0.63	0.58
7	19½	2.51	5.81	33.2	2.39	1.85	0.56	0.58
7	14½	2.30	4.34	27.2	2.50	1.40	0.57	0.54
*7	9½	2.09	2.85	21.1	2.72	0.98	0.59	0.55
6	15½	2.28	4.56	19.5	2.07	1.28	0.53	0.55
6	10½	2.04	3.09	15.1	2.21	0.88	0.53	0.50
*6	8	1.92	2.38	13.0	2.34	0.70	0.54	0.49
5	11½	2.04	3.38	10.4	1.75	0.82	0.49	0.51
*5	6½	1.75	1.95	7.4	1.95	0.48	0.50	0.49
4	7½	1.72	2.13	4.6	1.46	0.44	0.45	0.46
*4	5½	1.58	1.55	3.8	1.56	0.32	0.45	0.46
3	6	1.60	1.76	2.1	1.08	0.31	0.42	0.46
*3	4	1.41	1.19	1.6	1.17	0.20	0.41	0.44

Explanation in Arts. 44 and 76. * Standard sizes; others are special.

TABLE 10. STEEL ANGLE SECTIONS

Size of Angle Inches	Weight per Foot Pounds	Section Area Sq. In.	Axis parallel to long leg			Axis parallel to short leg		
			Axis to back of leg Inches	Moment Inertia Inches ⁴	Radius Gyration Inches	Axis to back of leg Inches	Moment Inertia Inches ⁴	Radius Gyration Inches
6×4×1	30.6	9.00	1.17	10.75	1.09	2.17	30.75	1.85
6×4×¾	23.6	6.94	1.08	8.68	1.12	2.08	24.51	1.88
6×4×½	16.2	4.75	0.99	6.27	1.15	1.99	17.40	1.91
5×4×1	24.2	7.11	1.21	9.23	1.14	1.71	16.42	1.52
5×4×¾	21.1	6.19	1.16	8.23	1.15	1.66	14.60	1.54
5×4×½	14.5	4.25	1.07	5.96	1.18	1.57	10.46	1.57
5×3×¾	19.9	5.84	0.86	3.71	0.80	1.86	13.98	1.55
5×3×½	12.8	3.75	0.75	2.58	0.83	1.75	9.45	1.59
4×3×¾	16.0	4.69	0.92	3.28	0.84	1.42	6.93	1.22
4×3×½	11.1	3.25	0.83	2.42	0.86	1.33	5.05	1.25
3½×3×½	10.2	3.00	0.88	2.33	0.88	1.13	3.45	1.07
3½×2½×½	9.4	2.75	0.70	1.36	0.70	1.20	3.24	1.09
3×2½×½	8.5	2.50	0.75	1.30	0.72	1.00	2.08	0.91
3×2×½	7.7	2.25	0.58	0.67	0.55	1.08	1.92	0.92
Equal legs			Axis	parallel	to leg			Least r
6×6×1	37.4	11.00	1.86	35.46	1.80			1.16
6×6×¾	28.7	8.44	1.78	28.15	1.83			1.17
6×6×½	19.6	5.75	1.68	19.91	1.86			1.18
5×5×1	30.6	9.00	1.61	19.64	1.48			0.96
5×5×¾	23.6	6.94	1.52	15.74	1.51			0.97
5×5×½	16.2	4.75	1.43	11.25	1.54			0.98
4×4×¾	18.5	5.84	1.29	8.14	1.18			0.77
4×4×½	12.8	3.75	1.18	5.56	1.22			0.78
3½×3½×½	11.1	3.25	1.06	3.64	1.06			0.68
3×3×½	9.4	2.75	0.93	2.22	0.90			0.58
2½×2½×½	7.7	2.25	0.81	1.23	0.74			0.47
2×2×¼	3.2	0.94	0.59	0.35	0.61			0.39

The least radii of gyration in the next column are for an axis through center of gravity and inclined 45 degrees to each leg.

Explanation in Art. 44

TABLE 11. STEEL Z SECTIONS

Size Inches	Weight per Foot	Thick- ness Inches	Section Area Sq. In.	Moment Inertia I_a Inches ⁴	Moment Inertia I_b Inches ⁴	Tangent of Angle between I_a and I_b	Least Radius Gyration Inches
8×3	16.9	$\frac{3}{8}$	4.97	44.64	5.60	0.27	0.72
7½×3	16.3	$\frac{3}{8}$	4.78	38.19	5.59	0.29	0.72
6×3½	29.3	$\frac{3}{4}$	8.63	42.12	15.44	0.52	0.81
5×3½	23.7	$\frac{11}{16}$	6.96	23.68	11.37	0.62	0.73
4×3½	18.9	$\frac{5}{8}$	5.55	12.11	8.73	0.81	0.65
3×2½	12.5	$\frac{1}{2}$	3.69	4.59	4.85	0.965	0.53

Explanation in Arts. 44 and 166

TABLE 12. COMPARISON OF BEAMS

Beams of Uniform Cross-section	Maximum Moment	Maximum Deflection	Relative Strength	Relative Stiffness
Cantilever, single load at end	WL	$\frac{1}{3} \frac{WL^3}{EI}$	1	1
Cantilever, uniform load	$\frac{1}{2}WL$	$\frac{1}{8} \frac{WL^3}{EI}$	2	2½
Simple beam, load at middle	$\frac{1}{2}WL$	$\frac{1}{48} \frac{WL^3}{EI}$	4	16
Simple beam uniformly loaded	$\frac{1}{8}WL$	$\frac{5}{384} \frac{WL^3}{EI}$	8	25½
Beam fixed at one end, supported at other, load near middle	$0.192WL$	$0.0098 \frac{WL^3}{EI}$	5.2	30.7
Beam fixed at one end, supported at other, uniform load	$\frac{1}{8}WL$	$0.0054 \frac{WL^3}{EI}$	8	62
Beam fixed at both ends, load at middle	$\frac{1}{8}WL$	$\frac{1}{192} \frac{WL^3}{EI}$	8	64
Beam fixed at both ends, uniform load	$\frac{1}{12}WL$	$\frac{1}{384} \frac{WL^3}{EI}$	12	128

Explanation in Arts. 56 and 63

TABLE 13. GERMAN I BEAMS

Depth of Beam cm.	Weight per Meter kilos	Width of Flange cm.	Section Area <i>a</i> sq. cm.	Axis perpendicular to web			Axis parallel to web	
				Moment Inertia <i>I</i> cm. ⁴	Section Factor <i>I/c</i> cm. ³	Radius Gyration r cm.	Moment Inertia <i>I</i> cm. ⁴	Radius Gyration r cm.
50	159.37	19.0	204.32	78 040	3 122	19.54	3 060	3.87
45	129.11	17.1	165.52	51 230	2 277	17.59	2 005	3.48
40	103.54	15.6	132.74	32 680	1 634	15.69	1 358	3.20
35	80.78	14.1	103.57	19 690	1 125	13.79	871.0	2.90
32	68.63	13.2	87.99	13 970	873.3	12.60	651.0	2.72
30	60.82	12.6	77.97	11 000	733.1	11.88	539.3	2.63
28	61.50	15.0	78.85	10 280	733.9	11.41	827.7	3.24
28	53.55	12.0	68.65	8 523	608.8	11.14	439.4	2.53
26	46.89	11.4	60.11	6 413	493.3	10.33	343.3	2.39
25	43.66	11.1	55.97	5 554	444.3	9.96	306.6	2.34
24	46.64	13.5	59.80	5 776	481.3	9.83	516.9	2.94
24	40.54	10.8	51.97	4 784	399.7	9.59	272.5	2.29
23	37.56	10.5	48.15	4 097	356.3	9.22	241.6	2.24
22	41.42	13.5	53.10	4 347	395.2	9.05	459.0	2.94
22	34.73	10.2	44.52	3 434	312.2	8.78	205.8	2.15
21	31.96	9.9	40.98	2 898	276.0	8.40	180.7	2.10
20	29.29	9.6	37.55	2 428	242.8	8.04	154.7	2.03
18	32.06	13.5	41.10	2 363	262.8	7.58	369.9	3.00
18	24.34	9.0	31.20	1 661	184.6	7.30	119.8	1.96
16	19.83	8.4	25.43	1 067	133.4	6.48	83.3	1.81
15	17.60	8.0	22.57	840.0	112.0	6.10	68.3	1.74
14	16.02	7.6	20.54	659.4	94.2	5.67	55.9	1.65
13	14.56	7.2	18.67	523.9	80.6	5.29	47.8	1.60
12	12.69	6.8	16.27	392.4	65.4	4.91	37.6	1.52
10	9.69	6.0	12.42	208.0	41.6	4.08	22.6	1.35
8	7.07	5.2	9.07	97.2	24.3	3.17	12.8	1.19

Explanation in Art. 44

TABLE 14. WEIGHT OF WROUGHT-IRON BARS

Side or Diameter Inches	Pounds per Linear Foot		Side or Diameter Inches	Pounds per Linear Foot.		Side or Diameter Inches	Pounds per Linear Foot	
	Square Bars	Round Bars		Square Bars	Round Bars		Square Bars	Round Bars
0			2	13.33	10.47	5	83.33	65.45
$\frac{1}{16}$	0.013	0.010	$\frac{1}{8}$	14.18	11.14	$\frac{1}{8}$	87.55	68.76
$\frac{1}{8}$	0.052	0.041	$\frac{3}{8}$	15.05	11.82	$\frac{1}{4}$	91.88	72.16
$\frac{3}{16}$	0.117	0.092	$\frac{1}{2}$	15.95	12.53	$\frac{3}{8}$	96.30	75.64
$\frac{1}{4}$	0.208	0.164	$\frac{5}{8}$	16.88	13.25	$\frac{1}{2}$	100.8	79.19
$\frac{5}{16}$	0.326	0.256	$\frac{3}{4}$	17.83	14.00	$\frac{5}{8}$	105.5	82.83
$\frac{3}{8}$	0.469	0.368	$\frac{7}{8}$	18.80	14.77	$\frac{3}{4}$	110.2	86.56
$\frac{7}{16}$	0.638	0.501	$\frac{1}{1}$	19.80	15.55	$\frac{7}{8}$	115.1	90.36
$\frac{1}{2}$	0.833	0.654	$\frac{1}{2}$	20.83	16.36	6	120.0	94.25
$\frac{9}{16}$	1.055	0.828	$\frac{3}{4}$	21.89	17.19	$\frac{1}{8}$	125.1	98.22
$\frac{5}{8}$	1.302	1.023	$\frac{5}{8}$	22.97	18.04	$\frac{1}{4}$	130.2	102.3
$\frac{11}{16}$	1.576	1.237	$\frac{11}{16}$	24.08	18.91	$\frac{3}{8}$	135.5	106.4
$\frac{3}{4}$	1.875	1.473	$\frac{1}{2}$	25.21	19.80	$\frac{1}{2}$	140.8	110.6
$\frac{13}{16}$	2.201	1.728	$\frac{13}{16}$	26.37	20.71	$\frac{5}{8}$	146.3	114.9
$\frac{7}{8}$	2.552	2.004	$\frac{7}{8}$	27.55	21.64	$\frac{3}{4}$	151.9	119.3
$\frac{15}{16}$	2.930	2.301	$\frac{15}{16}$	28.76	22.59	$\frac{7}{8}$	157.6	123.7
1	3.333	2.618	3	30.00	23.56	7	166.3	128.3
$\frac{1}{16}$	3.763	2.955	$\frac{1}{8}$	32.55	25.57	$\frac{1}{2}$	175.2	137.6
$\frac{1}{8}$	4.219	3.313	$\frac{1}{4}$	35.21	27.65	$\frac{3}{4}$	187.5	147.3
$\frac{3}{16}$	4.701	3.692	$\frac{3}{8}$	37.97	29.82	$\frac{5}{8}$	200.2	157.2
$\frac{1}{4}$	5.208	4.091	$\frac{1}{2}$	40.83	32.07	8	213.3	167.6
$\frac{5}{16}$	5.742	4.510	$\frac{5}{8}$	43.80	34.40	$\frac{1}{2}$	226.9	178.2
$\frac{3}{8}$	6.302	4.950	$\frac{3}{4}$	46.88	36.82	$\frac{1}{2}$	240.8	189.2
$\frac{7}{16}$	6.888	5.410	$\frac{7}{8}$	50.05	39.31	$\frac{3}{4}$	255.2	200.4
$\frac{1}{2}$	7.500	5.890	4	53.33	41.89	9	270.0	212.1
$\frac{9}{16}$	8.138	6.392	$\frac{1}{8}$	56.72	44.55	$\frac{1}{4}$	285.2	224.0
$\frac{5}{8}$	8.802	6.913	$\frac{1}{4}$	60.21	47.29	$\frac{1}{2}$	300.8	236.3
$\frac{11}{16}$	9.492	7.455	$\frac{3}{8}$	63.80	50.11	$\frac{3}{4}$	316.9	248.9
$\frac{3}{4}$	10.21	8.018	$\frac{1}{2}$	67.50	53.01	10	333.3	261.8
$\frac{13}{16}$	10.95	8.601	$\frac{5}{8}$	71.30	56.00	$\frac{1}{2}$	350.2	275.1
$\frac{7}{8}$	11.72	9.204	$\frac{3}{4}$	75.21	59.07	$\frac{1}{2}$	367.5	288.6
$\frac{15}{16}$	12.51	9.828	$\frac{7}{8}$	79.22	62.22	$\frac{3}{4}$	385.2	302.5

Explanation in Art. 188

TABLE 15. SQUARES OF NUMBERS

n.	0	1	2	3	4	5	6	7	8	9	Diff.
1.0	1.000	1.020	1.040	1.061	1.082	1.103	1.124	1.145	1.166	1.188	22
1.1	1.210	1.232	1.254	1.277	1.300	1.323	1.346	1.369	1.392	1.416	24
1.2	1.440	1.464	1.488	1.513	1.538	1.563	1.588	1.613	1.638	1.664	26
1.3	1.690	1.716	1.742	1.769	1.796	1.823	1.850	1.877	1.904	1.932	28
1.4	1.960	1.988	2.016	2.045	2.074	2.103	2.132	2.161	2.190	2.220	30
1.5	2.250	2.280	2.310	2.341	2.372	2.403	2.434	2.465	2.496	2.528	32
1.6	2.560	2.592	2.624	2.657	2.690	2.723	2.756	2.789	2.822	2.856	34
1.7	2.890	2.924	2.958	2.993	3.028	3.063	3.098	3.133	3.168	3.204	36
1.8	3.240	3.276	3.312	3.349	3.386	3.423	3.460	3.497	3.534	3.572	38
1.9	3.610	3.648	3.686	3.725	3.764	3.803	3.842	3.881	3.920	3.960	40
2.0	4.000	4.040	4.080	4.121	4.162	4.203	4.244	4.285	4.326	4.368	42
2.1	4.410	4.452	4.494	4.537	4.580	4.623	4.666	4.709	4.752	4.796	44
2.2	4.840	4.884	4.928	4.973	5.018	5.063	5.108	5.153	5.198	5.244	46
2.3	5.290	5.336	5.382	5.429	5.476	5.523	5.570	5.617	5.664	5.712	48
2.4	5.760	5.808	5.856	5.905	5.954	6.003	6.052	6.101	6.150	6.200	50
2.5	6.250	6.300	6.350	6.401	6.452	6.503	6.554	6.605	6.656	6.708	52
2.6	6.760	6.812	6.864	6.917	6.970	7.023	7.076	7.129	7.182	7.236	54
2.7	7.290	7.344	7.398	7.453	7.508	7.563	7.618	7.673	7.728	7.784	56
2.8	7.840	7.896	7.952	8.009	8.066	8.123	8.180	8.237	8.294	8.352	58
2.9	8.410	8.468	8.526	8.585	8.644	8.703	8.762	8.821	8.880	8.940	60
3.0	9.000	9.060	9.120	9.181	9.242	9.303	9.364	9.425	9.486	9.548	62
3.1	9.610	9.672	9.734	9.797	9.860	9.923	9.986	10.05	10.11	10.18	6
3.2	10.24	10.30	10.37	10.43	10.50	10.56	10.63	10.69	10.76	10.82	7
3.3	10.89	10.96	11.02	11.09	11.16	11.22	11.29	11.36	11.42	11.49	7
3.4	11.56	11.63	11.70	11.76	11.83	11.90	11.97	12.04	12.11	12.18	7
3.5	12.25	12.32	12.39	12.46	12.53	12.60	12.67	12.74	12.82	12.89	7
3.6	12.96	13.03	13.10	13.18	13.25	13.32	13.40	13.47	13.54	13.62	7
3.7	13.69	13.76	13.84	13.91	13.99	14.06	14.14	14.21	14.29	14.36	8
3.8	14.44	14.52	14.59	14.67	14.75	14.82	14.90	14.98	15.05	15.13	8
3.9	15.21	15.29	15.37	15.44	15.52	15.60	15.68	15.76	15.84	15.92	8
4.0	16.00	16.08	16.16	16.24	16.32	16.40	16.48	16.56	16.65	16.73	8
4.1	16.81	16.89	16.97	17.06	17.14	17.22	17.31	17.39	17.47	17.56	8
4.2	17.64	17.72	17.81	17.89	17.98	18.06	18.15	18.23	18.32	18.40	9
4.3	18.49	18.58	18.66	18.75	18.84	18.92	19.01	19.10	19.18	19.27	9
4.4	19.36	19.45	19.54	19.62	19.71	19.80	19.89	19.98	20.07	20.16	9
4.5	20.25	20.34	20.43	20.52	20.61	20.70	20.79	20.88	20.98	21.07	9
4.6	21.16	21.25	21.34	21.44	21.53	21.62	21.72	21.81	21.90	22.00	9
4.7	22.09	22.18	22.28	22.37	22.47	22.56	22.66	22.75	22.85	22.94	10
4.8	23.04	23.14	23.23	23.33	23.43	23.52	23.62	23.72	23.81	23.91	10
4.9	24.01	24.11	24.21	24.30	24.40	24.50	24.60	24.70	24.80	24.90	10
5.0	25.00	25.10	25.20	25.30	25.40	25.50	25.60	25.70	25.81	25.91	10
5.1	26.01	26.11	26.21	26.32	26.42	26.52	26.63	26.73	26.83	26.94	10
5.2	27.04	27.14	27.25	27.35	27.46	27.56	27.67	27.77	27.88	27.98	11
5.3	28.09	28.20	28.30	28.41	28.52	28.62	28.73	28.84	28.94	29.05	11
5.4	29.16	29.27	29.38	29.48	29.59	29.70	29.81	29.92	30.03	30.14	11
n.	0	1	2	3	4	5	6	7	8	9	Diff.

Explanation in Art. 188

TABLE 15. SQUARES OF NUMBERS

n.	0	1	2	3	4	5	6	7	8	9	Diff.
5.5	30.25	30.36	30.47	30.58	30.69	30.80	30.91	31.02	31.14	31.25	11
5.6	31.36	31.47	31.58	31.70	31.81	31.92	32.04	32.15	32.26	32.38	11
5.7	32.49	32.60	32.72	32.83	32.95	33.06	33.18	33.29	33.41	33.52	12
5.8	33.64	33.76	33.87	33.99	34.11	34.22	34.34	34.46	34.57	34.69	12
5.9	34.81	34.93	35.05	35.16	35.28	35.40	35.52	35.64	35.76	35.88	12
6.0	36.00	36.12	36.24	36.36	36.48	36.60	36.72	36.84	36.97	37.09	12
6.1	37.21	37.33	37.45	37.58	37.70	37.82	37.95	38.07	38.19	38.32	12
6.2	38.44	38.56	38.69	38.81	38.94	39.06	39.19	39.31	39.44	39.56	13
6.3	39.69	39.82	39.94	40.07	40.20	40.32	40.45	40.58	40.70	40.83	13
6.4	40.96	41.09	41.22	41.34	41.47	41.60	41.73	41.86	41.99	42.12	13
6.5	42.25	42.38	42.51	42.64	42.77	42.90	43.03	43.16	43.30	43.43	13
6.6	43.56	43.69	43.82	43.96	44.09	44.22	44.36	44.49	44.62	44.76	13
6.7	44.89	45.02	45.16	45.29	45.43	45.56	45.70	45.83	45.97	46.10	14
6.8	46.24	46.38	46.51	46.65	46.79	46.92	47.06	47.20	47.33	47.47	14
6.9	47.61	47.75	47.89	48.02	48.16	48.30	48.44	48.58	48.72	48.86	14
7.0	49.00	49.14	49.28	49.42	49.56	49.70	49.84	49.98	50.13	50.27	14
7.1	50.41	50.55	50.69	50.84	50.98	51.12	51.27	51.41	51.55	51.70	14
7.2	51.84	51.98	52.13	52.27	52.42	52.56	52.71	52.85	53.00	53.14	15
7.3	53.29	53.44	53.58	53.73	53.88	54.02	54.17	54.32	54.46	54.61	15
7.4	54.76	54.91	55.06	55.20	55.35	55.50	55.65	55.80	55.95	56.10	15
7.5	56.25	56.40	56.55	56.70	56.85	57.00	57.15	57.30	57.46	57.61	15
7.6	57.76	57.91	58.06	58.22	58.37	58.52	58.68	58.83	58.98	59.14	15
7.7	59.29	59.44	59.60	59.75	59.91	60.06	60.22	60.37	60.53	60.68	16
7.8	60.84	61.00	61.15	61.31	61.47	61.62	61.78	61.94	62.09	62.25	16
7.9	62.41	62.57	62.73	62.88	63.04	63.20	63.36	63.52	63.68	63.84	16
8.0	64.00	64.16	64.32	64.48	64.64	64.80	64.96	65.12	65.29	65.45	16
8.1	65.61	65.77	65.93	66.10	66.26	66.42	66.59	66.75	66.91	67.08	16
8.2	67.24	67.40	67.57	67.73	67.90	68.06	68.23	68.39	68.56	68.72	17
8.3	68.89	69.06	69.22	69.39	69.56	69.72	69.89	70.06	70.22	70.39	17
8.4	70.56	70.73	70.90	71.06	71.23	71.40	71.57	71.74	71.91	72.08	17
8.5	72.25	72.42	72.59	72.76	72.93	73.10	73.27	73.44	73.62	73.79	17
8.6	73.96	74.13	74.30	74.48	74.65	74.82	75.00	75.17	75.34	75.52	17
8.7	75.69	75.86	76.04	76.21	76.39	76.56	76.74	76.91	77.09	77.26	18
8.8	77.44	77.62	77.79	77.97	78.15	78.32	78.50	78.68	78.85	79.03	18
8.9	79.21	79.39	79.57	79.74	79.92	80.10	80.28	80.46	80.64	80.82	18
9.0	81.00	81.18	81.36	81.54	81.72	81.90	82.08	82.26	82.45	82.63	18
9.1	82.81	82.99	83.17	83.36	83.54	83.72	83.91	84.09	84.27	84.46	18
9.2	84.64	84.82	85.01	85.19	85.38	85.56	85.75	85.93	86.12	86.30	19
9.3	86.49	86.68	86.86	87.05	87.24	87.42	87.61	87.80	87.98	88.17	19
9.4	88.36	88.55	88.74	88.92	89.11	89.30	89.49	89.68	89.87	90.06	19
9.5	90.25	90.44	90.63	90.82	91.01	91.20	91.39	91.58	91.78	91.97	19
9.6	92.16	92.35	92.54	92.74	92.93	93.12	93.32	93.51	93.70	93.90	19
9.7	94.09	94.28	94.48	94.67	94.87	95.06	95.26	95.45	95.65	95.84	20
9.8	96.04	96.24	96.43	96.63	96.83	97.02	97.22	97.42	97.61	97.81	20
9.9	98.01	98.21	98.41	98.60	98.80	99.00	99.20	99.40	99.60	99.80	20
n.	0	1	2	3	4	5	6	7	8	9	Diff.

TABLE 16. AREAS OF CIRCLES

<i>d</i>	0	1	2	3	4	5	6	7	8	9	Diff.
1.0	.7854	.8012	.8171	.8332	.8495	.8659	.8825	.8992	.9161	.9331	
1.1	.9503	.9677	.9852	1.003	1.021	1.039	1.057	1.075	1.094	1.112	
1.2	1.131	1.150	1.169	1.188	1.208	1.227	1.247	1.267	1.287	1.307	19
1.3	1.327	1.348	1.368	1.389	1.410	1.431	1.453	1.474	1.496	1.517	21
1.4	1.539	1.561	1.584	1.606	1.629	1.651	1.674	1.697	1.720	1.744	22
1.5	1.767	1.791	1.815	1.839	1.863	1.887	1.911	1.936	1.961	1.986	24
1.6	2.011	2.036	2.061	2.087	2.112	2.138	2.164	2.190	2.217	2.243	26
1.7	2.270	2.297	2.324	2.351	2.378	2.405	2.433	2.461	2.488	2.516	27
1.8	2.545	2.573	2.602	2.630	2.659	2.688	2.717	2.746	2.776	2.806	29
1.9	2.835	2.865	2.895	2.926	2.956	2.986	3.017	3.048	3.079	3.110	30
2.0	3.142	3.173	3.205	3.237	3.269	3.301	3.333	3.365	3.398	3.431	32
2.1	3.464	3.497	3.530	3.563	3.597	3.631	3.664	3.698	3.733	3.767	34
2.2	3.801	3.836	3.871	3.906	3.941	3.976	4.012	4.047	4.083	4.119	35
2.3	4.155	4.191	4.227	4.264	4.301	4.337	4.374	4.412	4.449	4.486	36
2.4	4.524	4.562	4.600	4.638	4.676	4.714	4.753	4.792	4.831	4.870	38
2.5	4.909	4.948	4.988	5.027	5.067	5.107	5.147	5.187	5.228	5.269	40
2.6	5.309	5.350	5.391	5.433	5.474	5.515	5.557	5.599	5.641	5.683	41
2.7	5.726	5.768	5.811	5.853	5.896	5.940	5.983	6.026	6.070	6.114	43
2.8	6.158	6.202	6.246	6.290	6.335	6.379	6.424	6.469	6.514	6.560	44
2.9	6.605	6.651	6.697	6.743	6.789	6.835	6.881	6.928	6.975	7.022	46
3.0	7.069	7.116	7.163	7.211	7.258	7.306	7.354	7.402	7.451	7.499	48
3.1	7.548	7.596	7.645	7.694	7.744	7.793	7.843	7.892	7.942	7.992	49
3.2	8.042	8.093	8.143	8.194	8.245	8.296	8.347	8.398	8.450	8.501	51
3.3	8.553	8.605	8.657	8.709	8.762	8.814	8.867	8.920	8.973	9.026	52
3.4	9.079	9.133	9.186	9.240	9.294	9.348	9.402	9.457	9.511	9.566	54
3.5	9.621	9.676	9.731	9.787	9.842	9.898	9.954	10.01	10.07	10.12	56
3.6	10.18	10.24	10.29	10.35	10.41	10.46	10.52	10.58	10.64	10.69	6
3.7	10.75	10.81	10.87	10.93	10.99	11.04	11.10	11.16	11.22	11.28	6
3.8	11.34	11.40	11.46	11.52	11.58	11.64	11.70	11.76	11.82	11.88	6
3.9	11.95	12.01	12.07	12.13	12.19	12.25	12.32	12.38	12.44	12.50	6
4.0	12.57	12.63	12.69	12.76	12.82	12.88	12.95	13.01	13.07	13.14	7
4.1	13.20	13.27	13.33	13.40	13.46	13.53	13.59	13.66	13.72	13.79	7
4.2	13.85	13.92	13.99	14.05	14.12	14.19	14.25	14.32	14.39	14.45	7
4.3	14.52	14.59	14.66	14.73	14.79	14.86	14.93	15.00	15.07	15.14	7
4.4	15.21	15.27	15.34	15.41	15.48	15.55	15.62	15.69	15.76	15.83	7
4.5	15.90	15.98	16.05	16.12	16.19	16.26	16.33	16.40	16.47	16.55	7
4.6	16.62	16.69	16.76	16.84	16.91	16.98	17.06	17.13	17.20	17.28	7
4.7	17.35	17.42	17.50	17.57	17.65	17.72	17.80	17.87	17.95	18.02	8
4.8	18.10	18.17	18.25	18.32	18.40	18.47	18.55	18.63	18.70	18.78	8
4.9	18.86	18.93	19.01	19.09	19.17	19.24	19.32	19.40	19.48	19.56	8
5.0	19.63	19.71	19.79	19.87	19.95	20.03	20.11	20.19	20.27	20.35	8
5.1	20.43	20.51	20.59	20.67	20.75	20.83	20.91	20.99	21.07	21.16	8
5.2	21.24	21.32	21.40	21.48	21.57	21.65	21.73	21.81	21.90	21.98	8
5.3	22.06	22.15	22.23	22.31	22.40	22.48	22.56	22.65	22.73	22.82	8
5.4	22.90	22.99	23.07	23.16	23.24	23.33	23.41	23.50	23.59	23.67	9
<i>d</i>	0	1	2	3	4	5	6	7	8		Diff.

Explanation in Art. 188

TABLE 16. AREAS OF CIRCLES

<i>d</i>	0	1	2	3	4	5	6	7	8	9	Diff.
5.5	23.76	23.84	23.93	24.02	24.11	24.19	24.28	24.37	24.45	24.54	9
5.6	24.63	24.72	24.81	24.89	24.98	25.07	25.16	25.25	25.34	25.43	9
5.7	25.52	25.61	25.70	25.79	25.88	25.97	26.06	26.15	26.24	26.33	9
5.8	26.42	26.51	26.60	26.69	26.79	26.88	26.97	27.06	27.15	27.25	9
5.9	27.34	27.43	27.53	27.62	27.71	27.81	27.90	27.99	28.09	27.18	9
6.0	28.27	28.37	28.46	28.56	28.65	28.75	28.84	28.94	29.03	29.13	9
6.1	29.22	29.32	29.42	29.51	29.61	29.71	29.80	29.90	30.00	30.09	10
6.2	30.19	30.29	30.39	30.48	30.58	30.68	30.78	30.88	30.97	31.07	10
6.3	31.17	31.27	31.37	31.47	31.57	31.67	31.77	31.87	31.97	32.07	10
6.4	32.17	32.27	32.37	32.47	32.57	32.67	32.78	32.88	32.98	33.08	10
6.5	33.18	33.29	33.39	33.49	33.59	33.70	33.80	33.90	34.00	34.11	10
6.6	34.21	34.32	34.42	34.52	34.63	34.73	34.84	34.94	35.05	35.15	10
6.7	35.26	35.36	35.47	35.57	35.68	35.78	35.89	36.00	36.10	36.21	10
6.8	36.32	36.42	36.53	36.64	36.75	36.85	36.96	37.07	37.18	37.28	11
6.9	37.39	37.50	37.61	37.72	37.83	37.94	38.05	38.16	38.26	38.37	11
7.0	38.48	38.59	38.70	38.82	38.93	39.04	39.15	39.26	39.37	39.48	11
7.1	39.59	39.70	39.82	39.93	40.04	40.15	40.26	40.38	40.49	40.60	11
7.2	40.72	40.83	40.94	41.06	41.17	41.28	41.40	41.51	41.62	41.74	11
7.3	41.85	41.97	42.08	42.20	42.31	42.43	42.54	42.66	42.78	42.89	11
7.4	43.01	43.12	43.24	43.36	43.47	43.59	43.71	43.83	43.94	44.06	12
7.5	44.18	44.30	44.41	44.53	44.65	44.77	44.89	45.01	45.13	45.25	12
7.6	45.36	45.48	45.60	45.72	45.84	45.96	46.08	46.20	46.32	46.45	12
7.7	46.57	46.69	46.81	46.93	47.05	47.17	47.29	47.42	47.54	47.66	12
7.8	47.78	47.91	48.03	48.15	48.27	48.40	48.52	48.65	48.77	48.89	12
7.9	49.02	49.14	49.27	49.39	49.51	49.64	49.76	49.89	50.01	50.14	12
8.0	50.27	50.39	50.52	50.64	50.77	50.90	51.02	51.15	51.28	51.40	13
8.1	51.53	51.66	51.78	51.91	52.04	52.17	52.30	52.42	52.55	52.68	13
8.2	52.81	52.94	53.07	53.20	53.33	53.46	53.59	53.72	53.85	53.98	13
8.3	54.11	54.24	54.37	54.50	54.63	54.76	54.89	55.02	55.15	55.29	13
8.4	55.42	55.55	55.68	55.81	55.95	56.08	56.21	56.35	56.48	56.61	13
8.5	56.75	56.88	57.01	57.15	57.28	57.41	57.55	57.68	57.82	57.95	13
8.6	58.09	58.22	58.36	58.49	58.63	58.77	58.90	59.04	59.17	59.31	14
8.7	59.45	59.58	59.72	59.86	59.99	60.13	60.27	60.41	60.55	60.68	14
8.8	60.82	60.96	61.10	61.24	61.38	61.51	61.65	61.79	61.93	62.07	14
8.9	62.21	62.35	62.49	62.63	62.77	62.91	63.05	63.19	63.33	63.48	14
9.0	63.62	63.76	63.90	64.04	64.18	64.33	64.47	64.61	64.75	64.90	14
9.1	65.04	65.18	65.33	65.47	65.61	65.76	65.90	66.04	66.19	66.33	14
9.2	66.48	66.62	66.77	66.91	67.06	67.20	67.35	67.49	67.64	67.78	15
9.3	67.93	68.08	68.22	68.37	68.51	68.66	68.81	68.96	69.10	69.25	15
9.4	69.40	69.55	69.69	69.84	69.99	70.14	70.29	70.44	70.58	70.73	15
9.5	70.88	71.03	71.18	71.33	71.48	71.63	71.78	71.93	72.08	72.23	15
9.6	72.38	72.53	72.68	72.84	72.99	73.14	73.29	73.44	73.59	73.75	15
9.7	73.90	74.05	74.20	74.36	74.51	74.66	74.82	74.97	75.12	75.28	15
9.8	75.43	75.58	75.74	75.89	76.05	76.20	76.36	76.51	76.67	76.82	16
9.9	76.98	77.13	77.29	77.44	77.60	77.76	77.91	78.07	78.23	78.38	16
<i>d</i>	0	1	2	3	4	5	6	7	8	9	Diff.

TABLE 17. TRIGONOMETRIC FUNCTIONS

Angle	Arc	Sin	Tan	Sec	Cosec	Cot	Cos	Coarc	
0	0.	0.	0.	1.	∞	∞	1.	1.5708	90
1	0.0175	0.0175	0.0175	1.0001	57.299	57.290	0.9998	.5533	89
2	.0349	.0349	.0349	1.0006	28.654	28.636	.9994	.5359	88
3	.0524	.0523	.0524	1.0014	19.107	19.081	.9986	.5184	87
4	.0698	.0698	.0699	1.0024	14.336	14.301	.9976	.5010	86
5	.0873	.0872	.0875	1.0038	11.474	11.430	.9962	.4835	85
6	0.1047	0.1045	0.1051	1.0055	9.5668	9.5144	0.9945	1.4661	84
7	.1222	.1219	.1228	1.0075	8.2055	8.1443	.9925	.4486	83
8	.1396	.1392	.1405	1.0098	7.1853	7.1154	.9903	.4312	82
9	.1571	.1564	.1584	1.0125	6.3925	6.3138	.9877	.4137	81
10	.1745	.1736	.1763	1.0154	5.7588	5.6713	.9848	.3963	80
11	0.1920	0.1908	0.1944	1.0187	5.2408	5.1446	0.9816	1.3788	79
12	.2094	.2079	.2126	1.0223	4.8097	4.7046	.9781	.3614	78
13	.2269	.2250	.2309	1.0263	4.4454	4.3315	.9744	.3439	77
14	.2443	.2419	.2493	1.0306	4.1336	4.0108	.9703	.3264	76
15	.2618	.2588	.2679	1.0353	3.8637	3.7321	.9659	.3090	75
16	0.2793	0.2756	0.2867	1.0403	3.6280	3.4874	0.9613	1.2915	74
17	.2967	.2924	.3057	1.0457	3.4203	3.2709	.9563	.2741	73
18	.3142	.3090	.3249	1.0515	3.2361	3.0777	.9511	.2566	72
19	.3316	.3256	.3443	1.0576	3.0716	2.9042	.9455	.2392	71
20	.3491	.3420	.3640	1.0642	2.9238	2.7475	.9397	.2217	70
21	0.3665	0.3584	0.3839	1.0712	2.7904	2.6051	0.9336	1.2043	69
22	.3840	.3746	.4040	1.0785	2.6695	2.4751	.9272	.1868	68
23	.4014	.3907	.4245	1.0864	2.5593	2.3559	.9205	.1694	67
24	.4189	.4067	.4452	1.0946	2.4586	2.2460	.9135	.1519	66
25	.4363	.4226	.4663	1.1034	2.3662	2.1445	.9063	.1345	65
26	0.4538	0.4384	0.4877	1.1126	2.2812	2.0503	0.8988	1.1170	64
27	.4712	.4540	.5095	1.1223	2.2027	1.9626	.8910	.0996	63
28	.4887	.4695	.5317	1.1326	2.1301	1.8807	.8829	.0821	62
29	.5061	.4848	.5543	1.1434	2.0627	1.8040	.8746	.0646	61
30	.5236	.5000	.5774	1.1547	2.0000	1.7321	.8660	.0472	60
31	0.5411	0.5150	0.6009	1.1666	1.9416	1.6643	0.8572	1.0297	59
32	.5585	.5299	.6249	1.1792	1.8871	1.6003	.8480	1.0123	58
33	.5760	.5446	.6494	1.1924	1.8361	1.5399	.8387	0.9948	57
34	.5934	.5592	.6745	1.2062	1.7883	1.4826	.8290	.9774	56
35	.6109	.5736	.7002	1.2208	1.7435	1.4281	.8192	.9599	55
36	0.6283	0.5878	0.7265	1.2361	1.7013	1.3764	0.8090	0.9425	54
37	.6458	.6018	.7536	1.2521	1.6616	1.3270	.7986	.9250	53
38	.6632	.6157	.7813	1.2690	1.6243	1.2799	.7880	.9076	52
39	.6807	.6293	.8098	1.2868	1.5890	1.2349	.7771	.8901	51
40	.6981	.6428	.8391	1.3054	1.5557	1.1918	.7660	.8727	50
41	0.7156	0.6561	0.8693	1.3250	1.5243	1.1504	0.7547	0.8552	49
42	.7330	.6691	.9004	1.3456	1.4945	1.1106	.7431	.8378	48
43	.7505	.6820	.9325	1.3673	1.4663	1.0724	.7314	.8203	47
44	.7679	.6947	.9657	1.3902	1.4396	1.0355	.7193	.8028	46
45	.7854	.7071	1.	1.4142	1.4142	1.	.7071	.7854	45
	Coarc	Cos	Cot	Cosec	Sec	Tan	Sin	Arc	Angle

Explanation in Art. 188

TABLE 18. LOGARITHMS OF TRIGONOMETRIC FUNCTIONS

Angle	Log Arc	Log Sin	Log Tan	Log Sec	Log Cosec	Log Cot	Log Cos	Log Coarc	
0	-∞	-∞	-∞	0.	∞	∞	0.	0.1961	90
1	.2419	.2419	.2419	0.0001	1.7581	1.7581	̄.9999	.1913	89
2	.5429	.5428	.5431	.0003	.4572	.4569	.9997	.1864	88
3	.7190	.7188	.7194	.0006	.2812	.2806	.9994	.1814	87
4	.8439	.8436	.8446	.0011	.1564	.1554	.9989	.1764	86
5	.9408	.9403	.9420	.0017	.0597	.0580	.9983	.1713	85
6	̄.0200	̄.0192	̄.0216	0.0024	0.9808	0.9784	̄.9976	0.1662	84
7	.0870	.0859	.0891	.0032	.9141	.9109	.9968	.1610	83
8	.1450	.1436	.1478	.0042	.8564	.8522	.9958	.1557	82
9	.1961	.1943	.1997	.0054	.8057	.8003	.9946	.1504	81
10	.2419	.2397	.2463	.0066	.7603	.7537	.9934	.1450	80
11	̄.2833	̄.2806	̄.2887	0.0081	0.7194	0.7113	̄.9919	0.1395	79
12	.3211	.3179	.3275	.0096	.6821	.6725	.9904	.1340	78
13	.3558	.3521	.3634	.0113	.6479	.6366	.9887	.1284	77
14	.3880	.3837	.3968	.0131	.6163	.6032	.9869	.1227	76
15	.4180	.4130	.4281	.0151	.5870	.5719	.9849	.1169	75
16	̄.4460	̄.4403	̄.4575	0.0172	0.5597	0.5425	̄.9828	0.1111	74
17	.4723	.4659	.4853	.0194	.5341	.5147	.9806	.1052	73
18	.4972	.4900	.5118	.0218	.5100	.4882	.9782	.0992	72
19	.5206	.5126	.5370	.0243	.4874	.4630	.9757	.0931	71
20	.5429	.5341	.5611	.0270	.4659	.4389	.9730	.0870	70
21	̄.5641	̄.5543	̄.5842	0.0298	0.4457	0.4158	̄.9702	0.0807	69
22	.5843	.5736	.6064	.0328	.4264	.3936	.9672	.0744	68
23	.6036	.5919	.6279	.0360	.4081	.3721	.9640	.0680	67
24	.6221	.6093	.6486	.0393	.3907	.3514	.9607	.0614	66
25	.6398	.6259	.6687	.0427	.3741	.3313	.9573	.0548	65
26	̄.6569	̄.6418	̄.6882	0.0463	0.3582	0.3118	̄.9537	0.0481	64
27	.6732	.6570	.7072	.0501	.3430	.2928	.9499	.0412	63
28	.6890	.6716	.7257	.0541	.3284	.2743	.9459	.0343	62
29	.7042	.6856	.7438	.0582	.3144	.2562	.9418	.0272	61
30	.7190	.6990	.7614	.0625	.3010	.2386	.9375	.0200	60
31	̄.7332	̄.7118	̄.7788	0.0669	0.2882	0.2212	̄.9331	0.0127	59
32	.7470	.7242	.7958	.0716	.2758	.2042	.9284	0.0053	58
33	.7604	.7361	.8125	.0764	.2639	.1875	.9236	1.9978	57
34	.7734	.7476	.8290	.0814	.2524	.1710	.9186	.9901	56
35	.7859	.7586	.8452	.0866	.2414	.1548	.9134	.9822	55
36	̄.7982	̄.7692	̄.8613	0.0920	0.2308	0.1387	̄.9080	̄.9743	54
37	.8101	.7795	.8771	.0977	.2205	.1229	.9023	.9662	53
38	.8217	.7893	.8928	.1035	.2107	.1072	.8965	.9579	52
39	.8329	.7989	.9084	.1095	.2011	.0916	.8905	.9494	51
40	.8439	.8081	.9238	.1157	.1919	.0762	.8843	.9408	50
41	̄.8547	̄.8169	̄.9392	0.1222	0.1831	0.0608	̄.8778	̄.9321	49
42	.8651	.8255	.9544	.1289	.1745	.0456	.8711	.9231	48
43	.8754	.8338	.9697	.1359	.1662	.0303	.8641	.9140	47
44	.8853	.8418	.9848	.1431	.1582	.0152	.8569	.9046	46
45	.8951	.8495	0.	.1505	.1505	0.	.8495	.8951	45
	Log Coarc	Log Cos	Log Cot	Log Cosec	Log Sec	Log Tan	Log Sin	Log Arc	Angle

Explanation in Art. 188

TABLE 19. LOGARITHMS OF NUMBERS

"	0	1	2	3	4	5	6	7	8	9	Diff.
10	0000	0043	0086	0128	0170	0212	0253	0294	0334	0374	42
11	0414	0453	0492	0531	0569	0607	0645	0682	0719	0755	38
12	0792	0828	0864	0899	0934	0969	1004	1038	1072	1106	35
13	1139	1173	1206	1239	1271	1303	1335	1367	1399	1430	32
14	1461	1492	1523	1553	1584	1614	1644	1673	1703	1732	30
15	1761	1790	1818	1847	1875	1903	1931	1959	1987	2014	28
16	2041	2068	2095	2122	2148	2175	2201	2227	2253	2279	27
17	2304	2330	2355	2380	2405	2430	2455	2480	2504	2529	25
18	2553	2577	2601	2625	2648	2672	2695	2718	2742	2765	24
19	2788	2810	2833	2856	2878	2900	2923	2945	2967	2989	22
20	3010	3032	3054	3075	3096	3118	3139	3160	3181	3201	21
21	3222	3243	3263	3284	3304	3324	3345	3365	3385	3404	20
22	3424	3444	3464	3483	3502	3522	3541	3560	3579	3598	19
23	3617	3636	3655	3674	3692	3711	3729	3747	3766	3784	18
24	3802	3820	3838	3856	3874	3892	3909	3927	3945	3962	18
25	3979	3997	4014	4031	4048	4065	4082	4099	4116	4133	17
26	4150	4166	4183	4200	4216	4232	4249	4265	4281	4298	17
27	4314	4330	4346	4362	4378	4393	4409	4425	4440	4456	16
28	4472	4487	4502	4518	4533	4548	4564	4579	4594	4609	15
29	4624	4639	4654	4669	4683	4698	4713	4728	4742	4757	15
30	4771	4786	4800	4814	4829	4843	4857	4871	4886	4900	14
31	4914	4928	4942	4955	4969	4983	4997	5011	5024	5038	14
32	5051	5065	5079	5092	5105	5119	5132	5145	5159	5172	13
33	5185	5198	5211	5224	5237	5250	5263	5276	5289	5302	13
34	5315	5328	5340	5353	5366	5378	5391	5403	5416	5428	13
35	5441	5453	5465	5478	5490	5502	5514	5527	5539	5551	12
36	5563	5575	5587	5599	5611	5623	5635	5647	5658	5670	12
37	5682	5694	5705	5717	5729	5740	5752	5763	5775	5786	12
38	5798	5809	5821	5832	5843	5855	5866	5877	5888	5899	11
39	5911	5922	5933	5944	5955	5966	5977	5988	5999	6010	11
40	6021	6031	6042	6053	6064	6075	6085	6096	6107	6117	11
41	6128	6138	6149	6160	6170	6180	6191	6201	6212	6222	11
42	6232	6243	6253	6263	6274	6284	6294	6304	6314	6325	10
43	6335	6345	6355	6365	6375	6385	6395	6405	6415	6425	10
44	6435	6444	6454	6464	6474	6484	6493	6503	6513	6522	10
45	6532	6542	6551	6561	6571	6580	6590	6599	6609	6618	10
46	6628	6637	6646	6656	6665	6675	6684	6693	6702	6712	9
47	6721	6730	6739	6749	6758	6767	6776	6785	6794	6803	9
48	6812	6821	6830	6839	6848	6857	6866	6875	6884	6893	9
49	6902	6911	6920	6928	6937	6946	6955	6964	6972	6981	9
50	6990	6998	7007	7016	7024	7033	7042	7050	7059	7067	9
51	7076	7084	7093	7101	7110	7118	7126	7135	7143	7152	8
52	7160	7168	7177	7185	7193	7202	7210	7218	7226	7235	8
53	7243	7251	7259	7267	7275	7284	7292	7300	7308	7316	8
54	7324	7332	7340	7348	7356	7364	7372	7380	7388	7396	8
"	0	1	2	3	4	5	6	7	8	9	Diff.

Explanation in Art. 188

TABLE 19. LOGARITHMS OF NUMBERS

n	0	1	2	3	4	5	6	7	8	9	Diff.
55	7404	7412	7419	7427	7435	7443	7451	7459	7466	7474	8
56	7482	7490	7497	7505	7513	7520	7528	7536	7543	7551	
57	7559	7566	7574	7582	7589	7597	7604	7612	7619	7627	
58	7634	7642	7649	7657	7664	7672	7679	7686	7694	7701	
59	7709	7716	7723	7731	7738	7745	7752	7760	7767	7774	
60	7782	7789	7796	7803	7810	7818	7825	7832	7839	7846	7
61	7853	7860	7868	7875	7882	7889	7896	7903	7910	7917	
62	7924	7931	7938	7945	7952	7959	7966	7973	7980	7987	
63	7993	8000	8007	8014	8021	8028	8035	8041	8048	8055	
64	8062	8069	8075	8082	8089	8096	8102	8109	8116	8122	
65	8129	8136	8142	8149	8156	8162	8169	8176	8182	8189	7
66	8195	8202	8209	8215	8222	8228	8235	8241	8248	8254	
67	8261	8267	8274	8280	8287	8293	8299	8306	8312	8319	
68	8325	8331	8338	8344	8351	8357	8363	8370	8376	8382	
69	8388	8395	8401	8407	8414	8420	8426	8432	8439	8445	
70	8451	8457	8463	8470	8476	8482	8488	8494	8500	8506	6
71	8513	8519	8525	8531	8537	8543	8549	8555	8561	8567	
72	8573	8579	8585	8591	8597	8603	8609	8615	8621	8627	
73	8633	8639	8645	8651	8657	8663	8669	8675	8681	8686	
74	8692	8698	8704	8710	8716	8722	8727	8733	8739	8745	
75	8751	8756	8762	8768	8774	8779	8785	8791	8797	8802	6
76	8808	8814	8820	8825	8831	8837	8842	8848	8854	8859	
77	8865	8871	8876	8882	8887	8893	8899	8904	8910	8915	
78	8921	8927	8932	8938	8943	8949	8954	8960	8965	8971	
79	8976	8982	8987	8993	8998	9004	9009	9015	9020	9025	
80	9031	9036	9042	9047	9053	9058	9063	9069	9074	9079	5
81	9085	9090	9096	9101	9106	9112	9117	9122	9128	9133	
82	9138	9143	9149	9154	9159	9165	9170	9175	9180	9186	
83	9191	9196	9201	9206	9212	9217	9222	9227	9232	9238	
84	9243	9248	9253	9258	9263	9269	9274	9279	9284	9289	
85	9294	9299	9304	9309	9315	9320	9325	9330	9335	9340	5
86	9345	9350	9355	9360	9365	9370	9375	9380	9385	9390	
87	9395	9400	9405	9410	9415	9420	9425	9430	9435	9440	
88	9445	9450	9455	9460	9465	9469	9474	9479	9484	9489	
89	9494	9499	9504	9509	9513	9518	9523	9528	9533	9538	
90	9542	9547	9552	9557	9562	9566	9571	9576	9581	9586	5
91	9590	9595	9600	9605	9609	9614	9619	9624	9628	9633	
92	9638	9643	9647	9652	9657	9661	9666	9671	9675	9680	
93	9685	9689	9694	9699	9703	9708	9713	9717	9722	9727	
94	9731	9736	9741	9745	9750	9754	9759	9763	9768	9773	
95	9777	9782	9786	9791	9795	9800	9805	9809	9814	9818	4
96	9823	9827	9832	9836	9841	9845	9850	9854	9859	9863	
97	9868	9872	9877	9881	9886	9890	9894	9899	9903	9908	
98	9912	9917	9921	9926	9930	9934	9939	9943	9948	9952	
99	9956	9961	9965	9969	9974	9978	9983	9987	9991	9996	
n	0	1	2	3	4	5	6	7	8	9	Diff.

TABLE 20. CONSTANTS AND THEIR LOGARITHMS

Name. (Radius of circle or sphere = r .)	Symbol.	Number.	Logarithm.
Area of circle	π	3 141 592 654	0.497 149 873
Circumference of circle	2π	6.283 185 307	0.798 179 868
Surface of sphere	4π	12.566 370 614	1.099 209 864
Quadrant of circle	$\frac{1}{8}\pi$	0.523 598 776	$\bar{1}$.718 998 622
	$\frac{1}{4}\pi$	0.785 398 163	$\bar{1}$.895 089 881
	$\frac{3}{8}\pi$	1.178 097 339	0.196 119 877
	$\frac{1}{2}\pi$	1.570 796 327	0.622 088 609
Area of semicircle	$\frac{1}{2}\pi$	1.570 796 327	0.196 119 877
Volume of sphere	$\frac{4}{3}\pi$	4.187 790 205	0.622 088 609
	π^2	9.869 604 401	0.994 299 745
	$\pi^{\frac{1}{2}}$	1.772 453 851	0.248 574 936
Degrees in a radian	$180/\pi$	57.295 779 513	1.758 122 632
Minutes in a radian	$10800/\pi$	3 437.746 771	3.536 273 883
Seconds in a radian	$648000/\pi$	206 264.806	5.314 425 133
	$1/\pi$	0.318 309 886	$\bar{1}$.502 850 127
	$1/\pi^{\frac{1}{2}}$	0.564 189 584	$\bar{1}$.751 425 064
	$1/\pi^2$	0.101 321 184	$\bar{1}$.005 700 255
Circumference/360	arc 1°	0.017 453 293	$\bar{2}$.241 877 368
	sin 1°	0.017 452 406	$\bar{2}$.241 855 318
Circumference/21600	arc $1'$	0.000 290 888	$\bar{4}$.463 726 117
	sin $1'$	0.000 290 888	$\bar{4}$.463 726 111
Circumference/1296000	arc $1''$	0.000 004 848	$\bar{6}$.685 574 867
	sin $1''$	0.000 004 848	$\bar{6}$.685 574 867
Base Napierian system of logs	e	2.718 281 828	0.434 294 482
Modulus common system of logs	M	0.434 294 482	$\bar{1}$.637 784 311
Naperian log of 10	$1/M$	2.302 585 093	0.362 215 689
Probable error constant	hr	0.476 936 3	$\bar{1}$.678 460 4
	$hr\sqrt{2}$	0.674 489 7	$\bar{1}$.828 975 4
Feet in one meter	m/ft.	3.280 833 3	0.515 984 1
Miles in one kilometer	km/mi.	0.621 369 9	$\bar{1}$.793 350 2

INDEX

- Absorption of brick, 64
 Acid steel, 61
 Alloys, 65, 67
 Aluminum, 66
 Angles, 104, 110, 111, 486
 Angular velocity, 421
 Annealing, 59, 64, 305
 Anthracite coal, 67, 380
 Answers to problems, 477
 Apparent and true stresses, 186, 274,
 359-382, 462
 Approximate computations, 34
 Area, reduction of, 31
 Areas of circles, 21, 492
 Artificial stone, 54, 66
 Army, gun formulas, 394-402
 Association, testing, 441
 Axial stresses, 1, 3, 190, 253, 327, 365
 impact, 327, 331, 337
 Axis, neutral, 98, 100
 of a bar, 2, 188
 of a beam, 100, 290
 of a column, 190
 Axle steel, 63
 Axles, 348, 353

 Bach, C., 414, 416
 Bar, 1, 42, 69
 Bar iron, 58, 489
 Bars of uniform strength, 71
 resilience of, 306
 under centrifugal stress, 421
 under impact, 327, 331
 weights of, 2, 478
 Base-line apparatus, 165
 Basic steel, 61
 Bauschinger, J., 353
 Beams, 87-187, 253-267, 269-302
 bending moments, 93, 116
 cantilevers, 116-148, 487
 Beams, cast iron, 122, 128
 center of gravity of sections, 103
 centrifugal stress, 425
 combined stresses, 251-275
 concrete, 282-298
 constrained, 149-167, 487
 continuous, 87, 168-187
 deck, 110, 484
 definitions, 87
 deflection, 112, 135, 145, 153, 258,
 312-319
 deflection and stiffness, 142, 158
 deflection and stress, 143, 159
 designing of, 125, 292
 elastic curve, 87, 114, 136, 138
 elastic resilience, 308
 experimental laws, 99, 185
 fixed, 149-167, 487
 flexural strength, 56, 131
 flitched, 282
 fundamental formulas, 101, 102, 185
 Galileo's investigations, 186
 historical notes, 184
 horizontal shear, 269
 impact on, 329, 334
 internal stresses, 97, 270
 internal work, 303-323
 lines of stress, 272
 maximum moments, 119, 150, 154
 modulus of rupture, 47, 131
 moments of inertia, 105-108
 moving loads, 132
 plate-girder, 108, 247, 298
 pure flexure, 374
 overhanging, 149-165
 reactions, 88, 150, 169
 reinforced-concrete, 285, 298
 resilience of, 308
 rolled, 108
 safe loads for, 124

- Beams, simple, 116-148, 487.
 stiffness, 141, 158
 sudden loads, 324
 theoretical laws, 97, 185
 true stresses, 367
 uniform strength, 143-148
 unsymmetric loads, 427
 vertical shear, 90, 116
 weights of, 42, 88
- Bearing compression, 85
- Bending moment, 93, 98, 101, 116
 diagrams of, 98, 116
 maximum, 119, 150, 487
 maximum maximorum, 133
 tables of, 175, 487
 triangular load, 426
- Bessemer steel, 60, 305
- Best iron, 57
- Bethlehem Steel Co., 64, 241, 383
- Beton, 66
- Birmie's formulas, 394
- Boiler steel, 63
- Boilers, 83, 417
 joints in, 81-86
 tubes in, 78
- Bolts, 16, 239, 265, 366
- Brass, 67
- Bresse, M., 182
- Brick, 6, 24, 44, 48, 252, 380
 strength of, 13, 14, 17, 49, 131, 480
 weight of, 42, 48
- Brick masonry, 49
- Brick tower, 50
- Bridges, 40, 59, 86, 187, 262, 284
- Bridge iron, 58
 rollers, 404
- Briquettes, 53
- Brittle materials, 44, 380, 438
- Brittleness, 6, 43
- Bronze, 67
- Buildings, unit-stresses, 18, 482
- Building stone, 51
- Bulb beams, 110, 427, 482
- Butt-joints, 82, 85
- Campbell, H. H., 61
- Cantilever beams, 87, 116-148, 487
 deflection of, 135, 145
- Cantilever, elastic curve, 136
 fundamental formulas, 102
 internal work, 308
 resilience, 303
 table for, 487
 uniform strength, 144
 with constraint, 163
- Carbon in cast iron, 55
 steel, 60, 62
 wrought iron, 58
- Castings, 55, 65, 482
- Cast iron, 55, 480-482
 beams, 128
 brittleness of, 44, 380
 elastic limit, 5, 56, 480
 factors of safety, 17
 flexural strength, 56, 131
 in compression, 13, 56
 in shear, 14, 38
 in tension, 10, 24, 56
 pipes, 76
 resilience of, 306
 weight of, 42, 55
- Cements, 52, 438
- Center of gravity, 73, 103
 of gyration, 112
- Centrifugal stress, 421, 425
- Chain link, 476
- Channels, 104, 110, 485
- Chestnut, 46, 47
- Christie's experiments, 197
- Circles, areas of, 106, 492
- Circular plates, 409, 411
 rings, 476
- Classification of pig iron, 55
 steel, 63
- Clapeyron, E., 174, 182
- Clavarino's formulas, 393
- Coal, 67, 380
- Coefficient of elasticity, 24
 of expansion, 252, 480
 of impact, 350
 of inertia, 331
 of internal friction, 378, 380
- Cold bend test, 58, 63, 439, 446
 rolling, 58
- Columns, 12, 188-224, 279
 compound, 276-281

- Columns, deflection of, 194
 design of, 206, 219
 eccentric loads, 214, 217
 ends of, 191, 221
 Euler's formula, 192
 experiments on, 196
 Gordon's formula, 203, 208
 Hodgkinson's formula, 197
 investigation of, 203, 219, 279
 Johnson's (T. H.) formula, 208
 modified Euler formula, 431
 radius of gyration, 191
 Rankine's formula, 200, 211
 reinforced-concrete, 279
 Ritter's formula, 211, 221
 rupture of, 197, 213
 safe loads for, 205
 sections of, 188, 281
 theory of, 190, 220
- Combined stresses, 251-275
 compression and flexure, 254
 flexure and torsion, 259
 shear and tension, 264
 tension and compression, 251
 tension and flexure, 259
 torsion and compression, 268
- Comparison of beams, 141, 158, 487
- Compound beams, 282-302
 columns, 276-281
 cylinder, 390
- Compression, 2, 11, 31, 188, 438, 481
 and flexure, 255, 262
 and shear, 265
 and tension, 251
 and torsion, 266
 cast iron, 14, 17, 55
 cement, 53, 438
 concrete, 54, 288
 eccentric loads, 72, 214
 mortar, 52
 on rivets, 81, 366
 steel, 14, 17, 60
 stone, 14, 51
 wrought iron, 14, 17, 44, 57
- Computations, 19, 34
- Concentrated loads, 88, 119, 407
- Concentric loads, 190, 368
- Concrete, 54, 279, 288, 482
- Concrete beams, 282-302
 columns, 279
- Connecting rod, 426
- Constants, tables of, 480-498
- Constrained beams, 149
- Continuity, 168
- Continuous beams, 87, 168-187
 equal spans, 175
 fixed ends, 179
 properties of, 171
 tables of, 175, 176
 three moments, 173
 unequal spans, 177
- Contraction of area, 31
- Cooper, T., 85, 210, 404
- Cox, H., 342
- Couplings for shafts, 239
- Crandall, C. L., 407
- Crank arm, 242, 244
 pin, 241, 243, 461
- Crehore, J. D., 212
- Crucible steel, 60
- Cubic equation, 166, 462
- Curvature, radius of, 114
- Crystals in steel, 354, 382
- Cylinders, 77, 383
 compound, 390, 399
 exterior pressure, 77
 interior pressure, 75, 383
 thick, 76, 383-395
 thin, 75, 77, 394
 with hoops, 78, 383, 399
- Cylindrical rollers, 403
- Dead loads, 132, 349
- Deck beams, 110, 484
- Deflection of beams, 112, 312-319, 487
 cantilever beams, 135, 145
 compound beams, 300
 constrained beams, 151-156
 simple beams, 138, 147, 301
 sudden loads, 324
 under impact, 329, 334
 under moving load, 350
 under shearing, 302, 317
- Deflection of columns, 194, 218
 of plate girders, 301
- Deformation, elastic, 3, 8, 23, 28

- Deformation, ultimate, 30
 work in, 35
- Designing, 18
 beams, 125, 292
 columns, 206
 guns, 384, 389, 399
 joints, 83
 shafts, 231, 241
- Detrusion, 38, 91
- Diagram of stress, 9, 28
- Diagrams, shear and moment, 92, 94,
 116, 150, 173
- Dimensions in equations, 21
- Ductility, 11, 58, 63
- Dudley, C. B., 448
- Dudley, P. H., 343
- Dynamic stress, 324-358
- Eccentric loads, 72-74, 214, 217
- Economic beams, 129
- Economy in design, 18, 127
- Efficiency of a joint, 82
- Elastic curve, 87, 112, 151, 153, 156
 cantilever beams, 135
 columns, 193, 218
 constrained beams, 141-149
 continuous beams, 173
 general equation, 112
 simple beams, 139
- Elastic deflection, 112
- Elastic deformation, 23
- Elastic limit, 4, 9, 17, 23, 27, 480
 cast iron, 5, 56
 compression, 13
 shear, 15, 39
 steel, 5, 27, 63
 tension, 5, 443
 timber, 5, 47
 wrought iron, 5, 58
- Elastic resilience, 303-317
- Elastic strength, 1-32
- Elasticity, coefficient of, 24
 laws of, 4, 8, 45
 modulus of, 23
 theory of, 449-471
- Electric analogies, 278, 474
- Ellipse of stress, 463
- Ellipsoid of stress, 456
- Elliptical plates, 414
- Elongation, 3, 4, 10, 26
 ultimate, 10, 30, 56, 58, 63, 443
 under impact, 325, 332
 under own weight, 70
- Endurance tests, 358
- Equations, dimensions, 21
- Equilibrium, 2, 96
- Ether, 470, 473
- Euler's formula, 192, 196, 431
- Expansibility, 251, 480
- Experimental laws, 8, 17, 99, 225, 360
- External forces, 1, 39, 77
- External work, 35, 303, 312, 324
- Eye bars, 260, 445
- Fairbairn, W., 78
- Factor of lateral contraction, 34, 359
 of safety, 7, 8, 17
- Fatigue of materials, 352-358, 381
- Fixed beams, 87, 149, 152, 156
- Flexural strength, 47, 56, 131, 481
- Flexure, 87-186
 and compression, 255, 262
 and tension, 259, 262
 and torsion, 266
 centrifugal, 425
 erroneous views, 185
 formula, 101
 of crank pin, 241
 of joints, 82, 86
 pure, 374
 under impact, 329, 334
 under live load, 132, 349
 work of, 308, 312
- Floor beams, 147, 300
- Flues, boiler, 78
- Fly wheel, 423
- Forge pig, 55, 57
- Forgings, 64
- Foundry pig, 55
- Friction, internal, 375-382
- Galileo, G., 186
- German I beams, 109, 488
- Glass, 67
- Gordon, L., 203, 208
- Goss, W. F. M., 444

- Granite, 50, 51
 Gravitation, 470, 473
 Gravity, center of, 73, 103
 specific, 42
 Grecian columns, 223
 Greek letters, 21
 Grindstone, 424
 Gun metal, 63
 Guns, 34, 383-401
 hooped, 384, 390, 399
 solid, 388, 393
 Gyration, radius of, 112, 129

 Hard steel, 62
 Hartmann, L., 376
 Hatt, W. K., 347, 348, 441
 Hemispheres, 417, 419
 Hemlock, 46
 Historical notes, 39, 186, 196, 318, 341,
 433, 441
 Hodgkinson, E., 342, 347
 Hollow cylinders, 75, 383-401
 shafts, 232
 spheres, 77
 Hooke's law, 4, 40, 449
 Hoops, centrifugal stress, 422
 for guns, 383, 391, 396, 399
 shrinkage of, 79, 396
 Horizontal impact, 330, 336
 shear, 269
 stresses, 97, 100
 Horse-power, 230
 Howard, J., 358, 436
 Hydraulic cement, 52
 mortar, 53

 I beams, 103, 107, 122, 124, 128, 178,
 483, 488
 Inertia of a bar, 331
 of a beam, 334
 in impact, 331-337
 moment of, 105
 Inspection of material, 448
 Impact, 324-351
 on bars, 327, 331
 on beams, 329, 334
 pressure due to, 344
 tests on, 341, 346, 439

 Infection point, 149
 friction, 375-382
 Internal stresses, 2, 96
 work, 303-315
 International Association, 441
 Investigation, 17, 122, 203
 of beams, 121
 of columns, 203
 of guns, 389, 393, 401
 of joints, 80
 of shafts, 230, 233
 Iron, 44, 55, 58
 Isotropic materials, 449

 Jacket for guns, 384
 Johnson, J. B., 368, 409
 Johnson, T. H., 208
 Joints, riveted, 80-86

 Keep, W. J., 342
 Keep's impact machine, 343
 Kirkaldy, D., 341

 Lamé, E., 395, 478
 Lamé's formulas, 385
 Lap joints, 80, 84
 Lateral contraction, 32, 34, 359
 factor of, 34
 Launhardt's formula, 355
 Laws, experimental, 8, 17, 99
 of fatigue, 353
 of internal stresses, 360
 of resilience, 303, 324

 Lead, 67
 Least work, 320
 Length, change in, 25
 Limestone, 50, 51, 482
 Limiting length of bar, 69
 of beam, 167

 Live loads, 132, 349
 Loads, 3, 87, 407
 safe, for beams, 124
 safe, for columns, 205
 sudden, 324
 Locomotive, 425
 Log, beam cut out, 129
 Logarithms, 495-498
 Long columns, 192

- Machinery steel, 63
 Malleable cast iron, 57
 Manhole covers, 415
 Marburg, E., 212, 441
 Marston, A., 407
 Martens, A., 435
 Masonry, brick, 49
 stone, 51
 Materials, factors of safety, 7-17
 fatigue of, 352-358
 properties of, 42-68
 resilience of, 303-320
 specifications for, 444
 strength of, 1-22, 42-68
 tests of, 433-443
 weights of, 42
 Maximum moments, 119, 133, 487
 shears, 119, 134, 459
 Measures, systems of, 20, 21
 Medium steel, 62, 63, 445
 Meigs, J. F., 401
 Merriman, M., 182, 212, 356
 Metric system, 20
 Millstone, 424
 Modulus of elasticity, 23, 37, 47, 480
 resilience, 307
 rupture, 47, 132
 Moisture in timber, 47
 Moment of a force, 93
 bending, 94
 twisting, 226
 Moment of inertia, 105, 111
 for beams, 105, 108, 429, 487
 for columns, 189
 for shafts, 229
 Moments, bending, 93, 111, 116
 cantilever beams, 94, 117
 continuous beams, 176
 diagrams of, 116
 fixed beams, 152, 156
 maximum, 119, 133
 overhanging beams, 150
 resisting, 98
 simple beams, 95, 118
 theorem of three, 173
 Moncrieff, J. M., 224
 Mortar, 52
 Moving loads, 132, 349
 Natural cement, 52, 54
 Navier, L. M. H., 186
 Navy, gun formulas, 393, 402
 Neutral axis, 100
 surface, 99
 Newton, I., 8, 40, 382, 478
 Nickel steel, 65
 Normal stress, 264, 362, 452
 Norton, W. A., 318

 Oak, 46, 47, 482
 One-hoss shay, 18
 Open-hearth steel, 60, 61, 444
 Ordnance formulas, 383-401
 Ores of iron, 57, 60
 Oscillations of a bar, 325, 333
 of a beam, 344
 Overhanging beams, 149-155, 165
 Own weight of bar, 69
 of beam, 124

 Parabola, 94, 118, 144, 357
 Parallel rod, 425
 Paving brick, 49
 Phosphor bronze, 66
 Phosphorus in steel, 61, 444
 Pitch of rivets, 81, 85
 Piers, 71
 Pig iron, 55
 Piles, 279, 281
 Pine, 46, 47, 318
 Pipes, 76, 383
 thick, 383-392
 thin, 75, 390
 Piston rod, 19, 188
 Plasticity, 43
 Plate girder, 108, 147, 298, 369
 Plates, 58, 63, 403-416, 447
 on cylinders, 83, 419
 Poisson's ratio, 34
 Polar moments, 229
 Portland cement, 52, 54
 Powder for guns, 383
 Power, shafts for, 230
 Pressure due to impact, 345
 Principal stresses, 457
 Prisms, loads on, 2, 74, 214
 Problems, answers to, 477

- Puddling furnace, 58
 Pure stresses, 373
 Purlins, 428
- Radius of curvature, 114
 of gyration, 112, 129, 191
 Rafters, 254
 Railroad rails, 43, 104, 343
 Range of stresses, 352-358
 Reactions of beams, 88, 91
 Rectangle, 105
 Rectangular beams, 129, 288
 plates, 415
 shafts, 247
 Reduction of area, 31
 Reinforced concrete, 279-298
 Rejtö, A., 378
 Repeated stresses, 352-358
 Resilience, 303-318, 469
 of bars, 304, 306
 of beams, 308
 of shearing, 310
 of torsion, 311
 Resisting moment, 98, 227
 shear, 98, 101
 Resultant stress, 454
 Ritter, A., 211, 221
 Riveted joints, 80-86
 design of, 83
 efficiency of, 82
 Rivet iron, 58
 steel, 63, 445
 Rivets, 80-85, 482
 Rolled beams, 109
 shapes, 110
 Rollers, 403, 406
 Rops, 66, 278
 Round shafts, 229, 231
 Rupture, 3, 8, 15, 31
 of beams, 130
 of columns, 197
 in repeated stress, 352
 modulus of, 132
- Safe loads, 17, 124
 Safety, factors of, 7, 17
 Saint Venant, B. de, 249, 450
- Sand-lime brick, 66
 Sandstone, 50-51, 380
 Section, changes in, 32
 Section area, 1, 42
 factor, 102
 Set, 5, 28, 29
 Shafts, 225-250, 266, 268
 couplings for, 239
 cranks for, 241, 243
 for power, 230
 hollow, 232
 round, 227, 231
 square, 248
 resilience of, 310
 stiffness of, 231
 strength of, 231, 237
 true stresses, 371
 Shapes, rolled, 107, 110, 483-488
 Shear, 14, 15, 369, 459
 and tension, 15, 263, 362
 deflection due to, 316
 horizontal, 269
 on rivets, 81
 resilience of, 310
 resisting, 98
 vertical, 90, 98
 ultimate strength, 14, 370
 work of, 39, 310
 Shear formula, 101
 Shearing modulus, 37, 234, 465
 strength, 481
 Shears for cantilevers, 91, 117
 for continuous beams, 176
 for simple beams, 92, 118, 120
 Shocks, 17, 57
 Shrinkage of hoops, 79, 393
 Shortening, 3
 Simple beams, 87, 89, 116-148, 487
 Slate, 51, 482
 Slenderness ratio, 191
 Soft steel, 62, 445
 Solid shafts, 229, 231, 237
 Sound, velocity of, 473
 Specific gravities, 42
 Specifications, 18, 444
 Spheres, 77, 417
 Spherical rollers, 406
 Spring steel, 63

- Springs, 341, 476
 Square plates, 416
 shafts, 248, 440
 Squares of numbers, 479, 490
 Stability, 18, 127
 Static loads and stresses, 324
 Steam boilers, 76, 78
 pipes, 75
 Steel, 5, 10, 13, 17, 24, 60-65, 132, 252,
 354, 444
 constants of, 480-482
 factors of safety, 17
 properties of, 60-65
 resilience, 307
 weight of, 42
 Steel beams, 103, 107, 124, 483, 488
 cranks, 241, 243
 guns, 384
 plates, 410, 413, 447
 pipes, 76
 rollers, 404
 ropes, 278
 spheres, 407, 419
 Stiffness of beams, 141, 158, 487
 of shafts, 237
 Stone, 13, 14, 17, 42, 44, 50, 131, 482
 Straight-line formula, 208
 Strength of materials, 1-22, 42-68
 history of, 39, 186
 tables, 480, 481
 Stress, 1, 42, 100, 139, 449
 apparent, 275
 centrifugal, 421, 424
 combined, 251-275
 diagrams of, 9, 28, 29
 in guns, 383-402
 pure, 373
 repeated, 356
 sudden, 324
 temperature, 68, 251
 true, 359-362
 working, 17
 Stringer, 284
 Strong steel, 5, 11, 13
 Structural steel, 5, 10, 11, 13, 14, 17,
 63, 109, 128, 444
 Sudden deflections, 325
 loads, 324
 Supports of beams, 87, 89, 159
 Surface, neutral, 98
 T shapes, 104, 107, 111, 128, 484
 Tables, 20, 478, 480-498
 Talbot, A. N., 296, 375, 436
 Tangential stress, 452
 Temperature, 67, 251
 Tempering, 62, 64
 Tension, 2, 9, 36, 69, 407, 481
 and flexure, 259, 262
 and shear, 263
 and torsion, 268
 centrifugal, 164
 eccentric, 73, 262
 Testing laboratories, 41, 358, 436
 Testing machines, 40, 433, 442
 Testing, rules for, 442
 Test specimens, 15, 436, 446
 Tests, brick, 49
 cast iron, 56
 cement, 53, 438
 cold bend, 58, 239
 columns, 196, 213
 - compression, 12, 45, 438
 fatigue, 352
 flexural, 47, 56, 131, 439, 443
 impact, 341, 346, 439, 443
 steel, 63, 437
 stone, 51
 tension, 4, 9, 36, 436, 442
 timber, 47, 187, 438
 torsion, 226, 245, 439
 wrought iron, 58
 Tetmajer, L. von, 208, 224
 Theorem of three moments, 173-183
 Thick hollow cylinders, 383, 389, 393
 spheres, 417
 Thin pipes, 76
 Thurston, R. H., 67, 318, 435
 Timber, 5, 10, 13, 14, 24, 38, 46, 482
 beams, 129
 factors of safety, 17, 47
 flexural strength, 131
 resilience, 306
 weight, 42, 46
 Time of vibration, 337
 Tool steel, 65

- Torsion, 225-250, 439
 combined, 152, 154
 formula for, 228
 non-circular sections, 245
 phenomena of, 225
 resilience of, 310
 rupture by, 235
- Transmission of power, 230
- Transverse impact, 327, 334
- Trap rock, 50, 51
- Tredgold, T., 40, 347
- Triangular beams, 104, 106, 166
- True deformations, 360, 370
 stresses, 274, 359-384
- Tubes, 78, 382
- Turner, C. A. P., 354
- Twisting moment, 227
- Trigonometric functions, 494
- Ultimate strength, 6, 10, 13, 481
 compression, 12, 44
 deformation, 30
 shear, 14
 tension, 4, 36
- Uniform load, 88, 119, 150
- Uniform strength, 71, 144
 bars, 71
 beams, 143, 146
- Unit-deformation, 9, 23, 30
- Unit-stress, 1, 12, 23
 repeated, 353
 working, 17
- Unsymmetric beams, 125, 427
 loads, 428
- Velocity of live load, 350
 stress, 472
- Vertical shear, 90, 116, 119
 deflection due to, 316
 stresses caused by, 93, 123
 work of, 39, 310
- Vibrations after impact, 338
 of a beam, 344
- Volume, change of, 33, 450
 resilience of, 469
- Volumetric modulus, 467
- Water, 468, 473
- Water pipes, 75, 77
 pressure, 76
- Wave propagation, 473
- Webster, W. R., 448
- Weights of bars, 42, 88, 478, 489
 materials, 42-68, 480
- Weyrauch's formula, 356
- Wheel, revolving, 422
- Wire, 63, 66
- Wöhler's laws, 353
- Wood, De V., 78, 166, 473
- Work, least, 320
- Work of flexure, 304, 308, 312
 rupture, 36
 shearing, 39
 tension, 35, 307
 torsion, 310
 vertical bar, 70
 vertical shear, 317
- Working unit-stresses, 17, 482
- Wrought iron, 5, 10, 13, 14, 17, 24, 57,
 60, 252, 482
 factors of safety, 17
 flexural strength, 132
 resilience, 307
 shear, 38
 tension, 10, 29, 59
 weight of, 42, 489
- Wrought-iron bars, 42, 58, 489
 pipes, 76
 plates, 58
- Yield point, 27, 29, 63, 443, 447
- Young, T., 40, 346, 433
- Young's modulus, 24
- Z bars, 104, 427, 430, 487
- Zimmerman, H., 351

